

Jubii 60

Ekstra dørsæt - Extra door kit - Extra Tür Set

Extra dörrar set - Kit de porte supplémentaire - Extra doos deuronderdelen

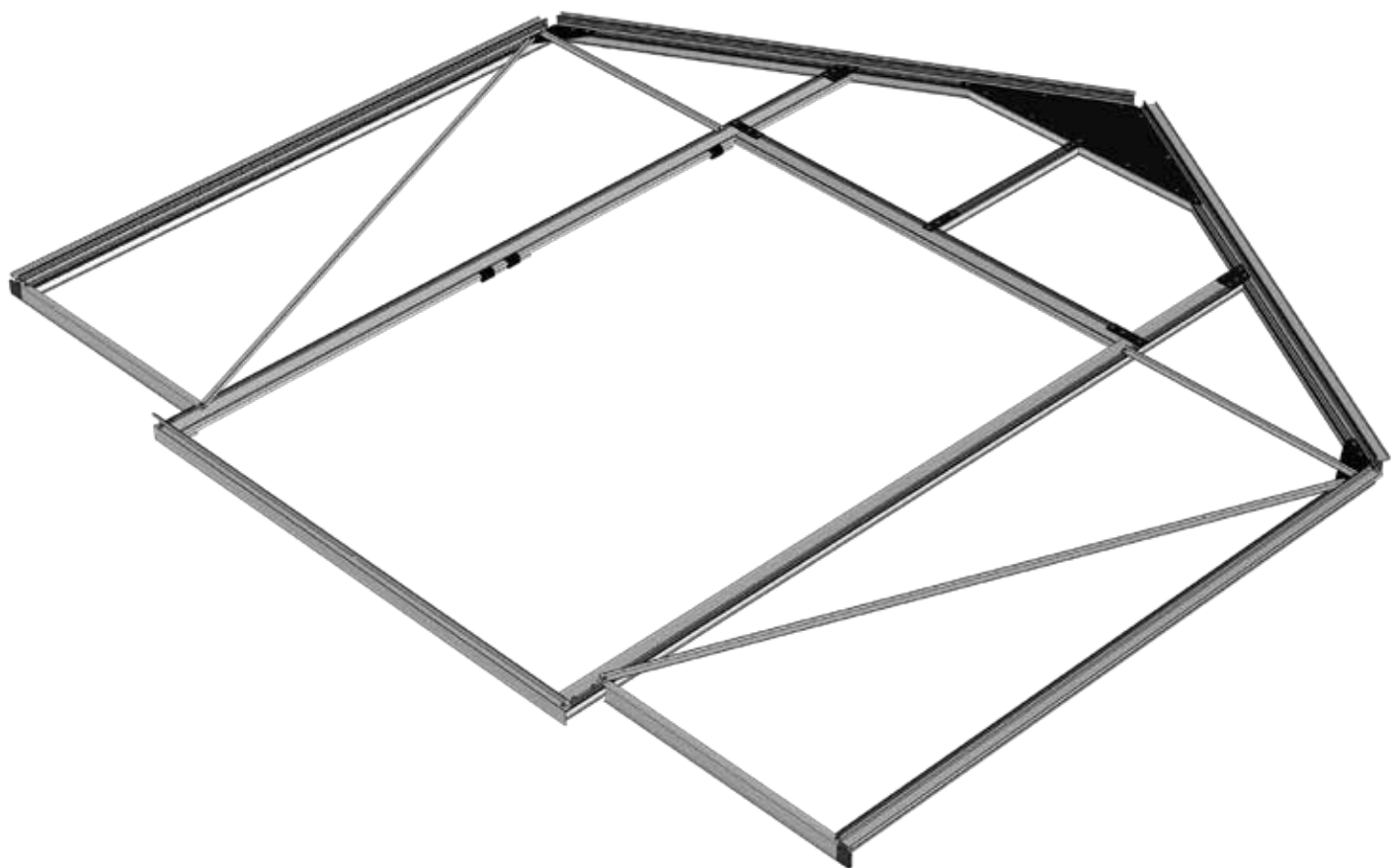







Ylimääräinen ovisarja - Dodatkowy zestaw drzwi

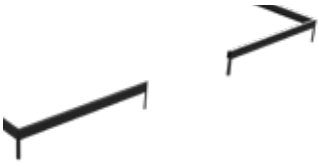

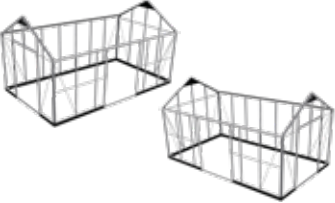
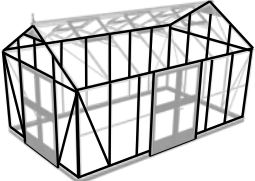
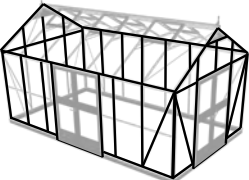
11032024 - 1.02

Montagevejledning · Assembly Instructions · Montageanleitung
Monteringsanvisning · Instructions de montage · Montagehandleiding
Kokoamisohje · Instukcja montażu

Oversigt - Overview - Übersicht - Översikt - Détails
 Overzicht - Sisällys - Zawartość

	
	6
	7 - 11
	12
	13 - 15
	16 - 18
	19
	 
	20 - 25

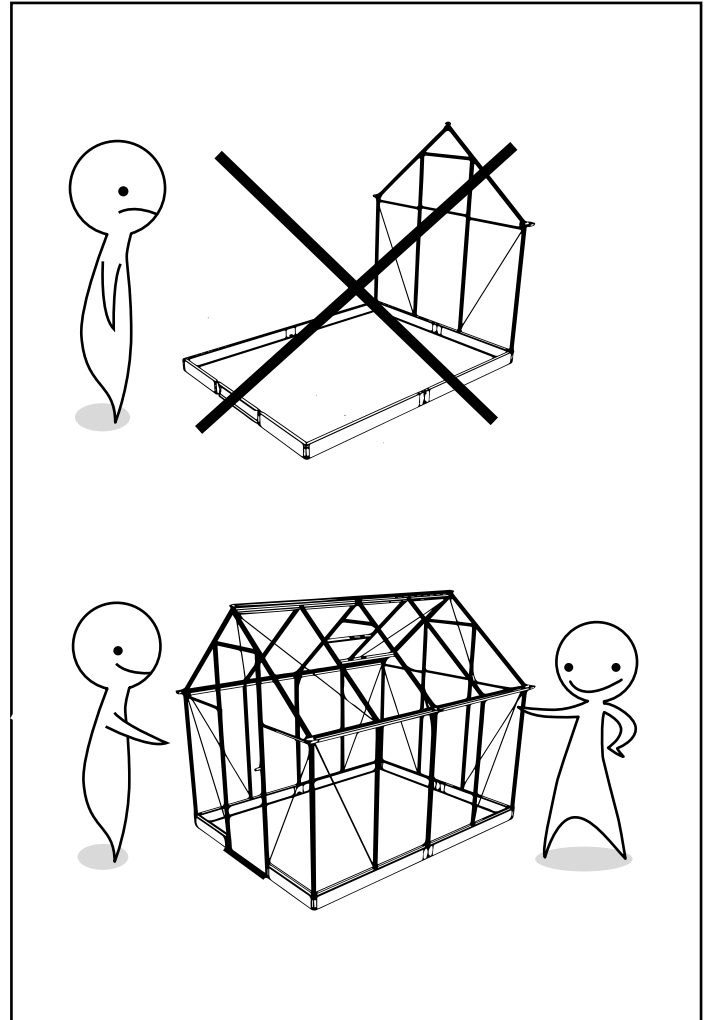

Anbefalet Værktøj - Recommended Tools -
 Empfohlen Werkzeug - Rekomenderas Verktyg -
 Recommandés Outils - Aanbevolen Gereedschap -
 Suositellut Työkalut - Zalecane Narzędzia

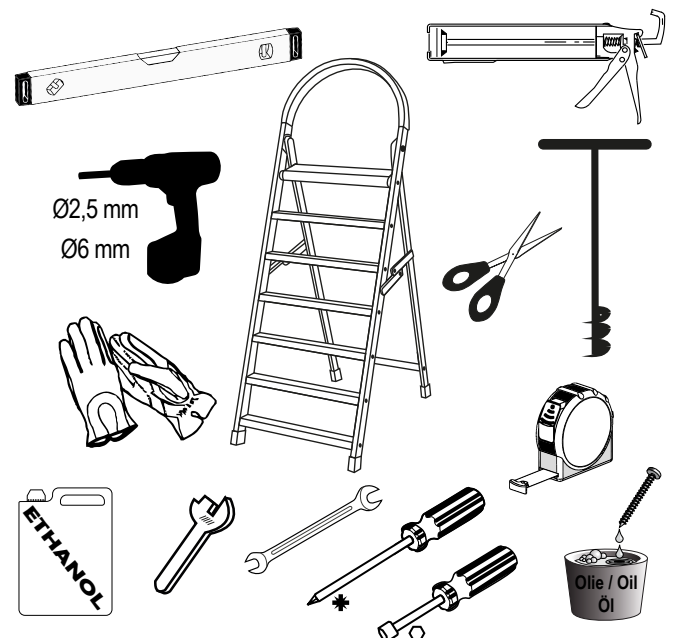

Oversigt - Overview - Übersicht - Översikt - Détails Overzicht - Sisällys - Zawartość

Profiler - Profiles - Profile		
#		Qty.
740	00510740S	2
1468	00511468S	1
341S	00310341S	1
342S	00310342S	1
00	13-20301468-00S	1
08	13-20151404-08S	1
09	13-10020742-09S	1
10	13-10020742-10S	1
11	13-20152368-11S	1
12	13-20152368-12S	1
19	13-10300730-19S	2
81	13-20130588-81S	1

3 mm - Hærdet glas - Toughened glass - Sicherheitsglas		
#		Qty.
G	00281507	2
H	00281508	2
I	00281583	2

Dør - Door - Tür		
#	Box 8	Qty.
55	13-20170517-55S	4
56	13-20160517-56S	1
57	13-20221075-57S	1
58	13-20221075-58S	1
59	13-20220812-59S	2
61	13-10020651-61S	1
340S	00310340S	1

Dør - Door - Tür		
#	Box 9	Qty.
59	13-20220812	1
62	13-20170578-62S	4
63	13-20160578-63S	1
64	13-20231075-64S	1
65	13-20221075-65S	1
66	13-20230812-66S	1
67	13-10020712-67S	1
339S	00310339S	1

Symboler - Symbole - Symbols - Symboles - Symbolen - Symbolit



DK Denne del bruges på side "X".	FR Cette pièce est utilisée à la page «X».
GB This component is used on page "X".	NL Dit deel wordt gebruikt op pagina "X".
DE Dieser Teil verwenden Sie an der Seite „X“.	FIN Tätä osaa käytetään sivulla "X".
SE Denna del används på sidan "X".	PL Część używana na stronie „X”.



DK Sektionen samles i denne rækkefølge.	FR Assembler la section dans cet ordre.
GB Assemble the section in this order.	NL Dat is de volgorde van het monteren.
DE Die Sektion wird in dieser Reihenfolge gesammelt.	FIN Lohkot kootaan tässä järjestyksessä.
SE Sektionen monteras i denna ordning.	PL Sekcję należy montować w tej kolejności.



DK Tallet angiver antal styk / gentagelser af processen.	FR Le chiffre indique le nombre de fois / répétitions de la procédure.
GB The number indicates the quantity / the number of times the process must be repeated.	NL Het getal geeft het aantal stuks / onderdelen van het proces aan.
DE Die Zahl zeigt die Anzahl der Stücke / der Wiederholungen des Prozesses an.	FIN Numero ilmaisee kappaleiden / toistojen määrän.
SE Siffran anger antal gånger / repetitioner av processen.	PL Liczba wskazuje liczbę sztuk / powtórzeń procesu.



DK Korrekt samling / forkert samling.	FR Assemblage correct / incorrect.
GB Correct assembly / wrong assembly.	NL Correcte montage / incorrecte montage.
DE Die korrekte Montage / die verkehrte Montage.	FIN Oikea kokoonpano / väärä kokoonpano.
SE Korrekt montering / felaktig montering.	PL Prawidłowy montaż / nieprawidłowy montaż.



DK Billedet viser samlingen indefra / udefra.	FR Ce symbole montre l'assemblage depuis l'intérieur / l'extérieur de la serre.
GB The image shows the assembly from the inside / outside.	NL De afbeelding toont het frame van binnen / buiten.
DE Das Bild zeigt die Montage von innen / von außen.	FIN Kuvassa näytetään kokoonpano sisä- / ulkopuolelta.
SE Bilden visar monteringen från insidan / utsidan.	PL Zdjęcie przedstawia zmontowane elementy od wewnątrz / z zewnątrz.



DK Møtrikken løsnes / skrues af og genbruges.
GB Loosen / unscrew the bolt and reuse it.
DE Lösen Sie die Schraubenmutter und wiederverwerten Sie sie.
SE Muttern lossas / wskruvas loss och återanvänds.
FR Desserrer / enlever l'écrou et le réutiliser.
NL De moer wordt losgemaakt / losgeschroefd en gerecycled.
FIN Mutteri irrotetaan ja kierrätetään.
PL Poluzować / odkręcić nakrętkę i użyć jej ponownie.



DK Vær opmærksom på justering / retning af profiler.
GB Please note the adjustment / direction of the profiles.
DE Beachten Sie die Justierung / die Richtung von den Profilen.
SE Var uppmärksam på profilernas justering / riktning.
FR Attention à l'ajustement / l'orientation des profilés !
NL Let op de uitlijning / richting van de profielen.
FIN Kiinnitä huomiota profiilien kohdistukseen / suuntaukseen.
PL Zwrócić uwagę na ustawienie / orientację profili.



DK Denne del kasseres.
GB Discard this component.
DE Dieser Teil kassieren Sie.
SE Denna del kasseras.
FR Jeter cette pièce.
NL Dit deel wordt weggegooid.
FIN Tämä osa hylätään.
PL Część przeznaczona do utylizacji.

Fundament - Base - Embase - Fundering - Perustus

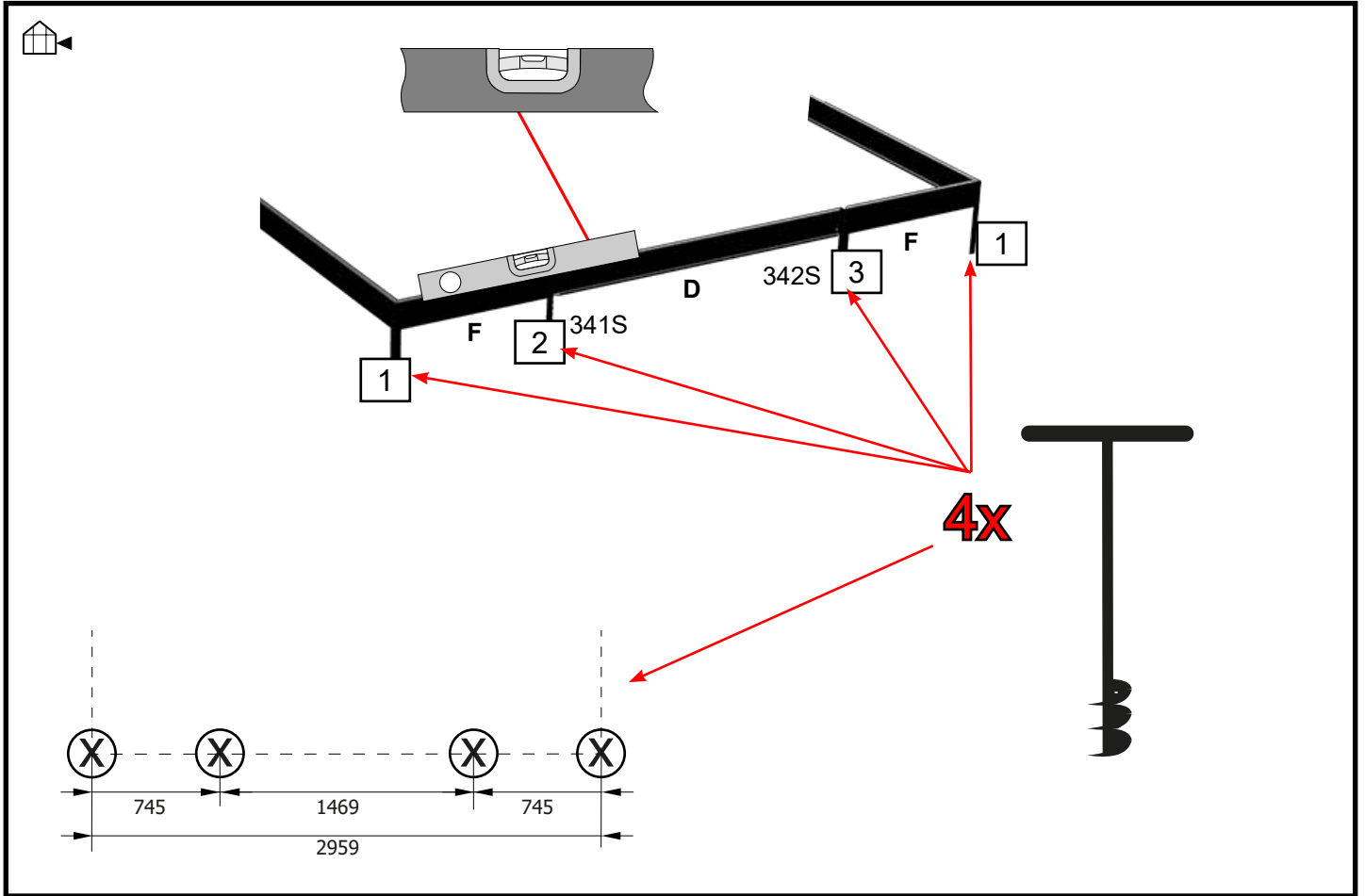



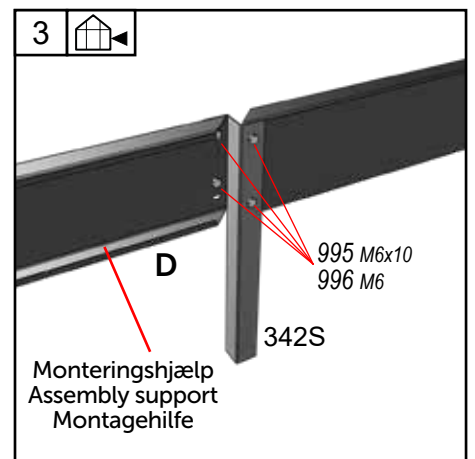
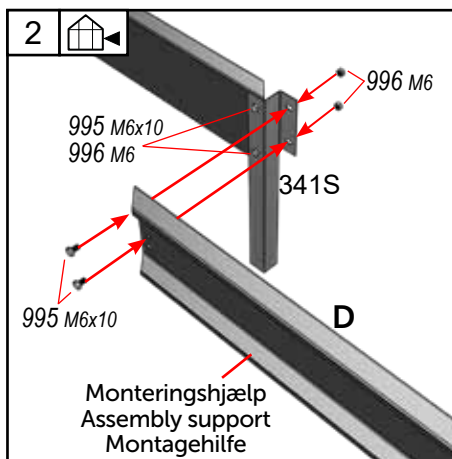
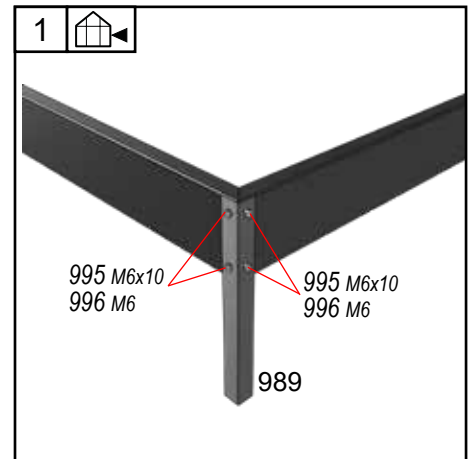
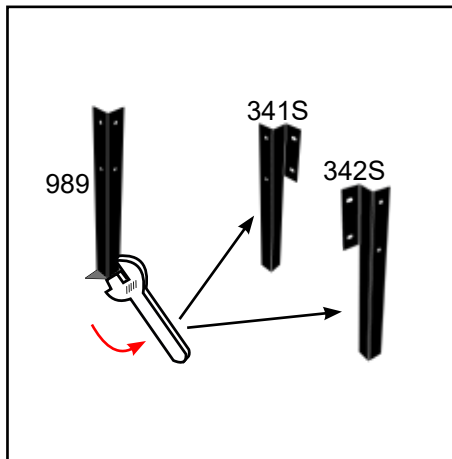



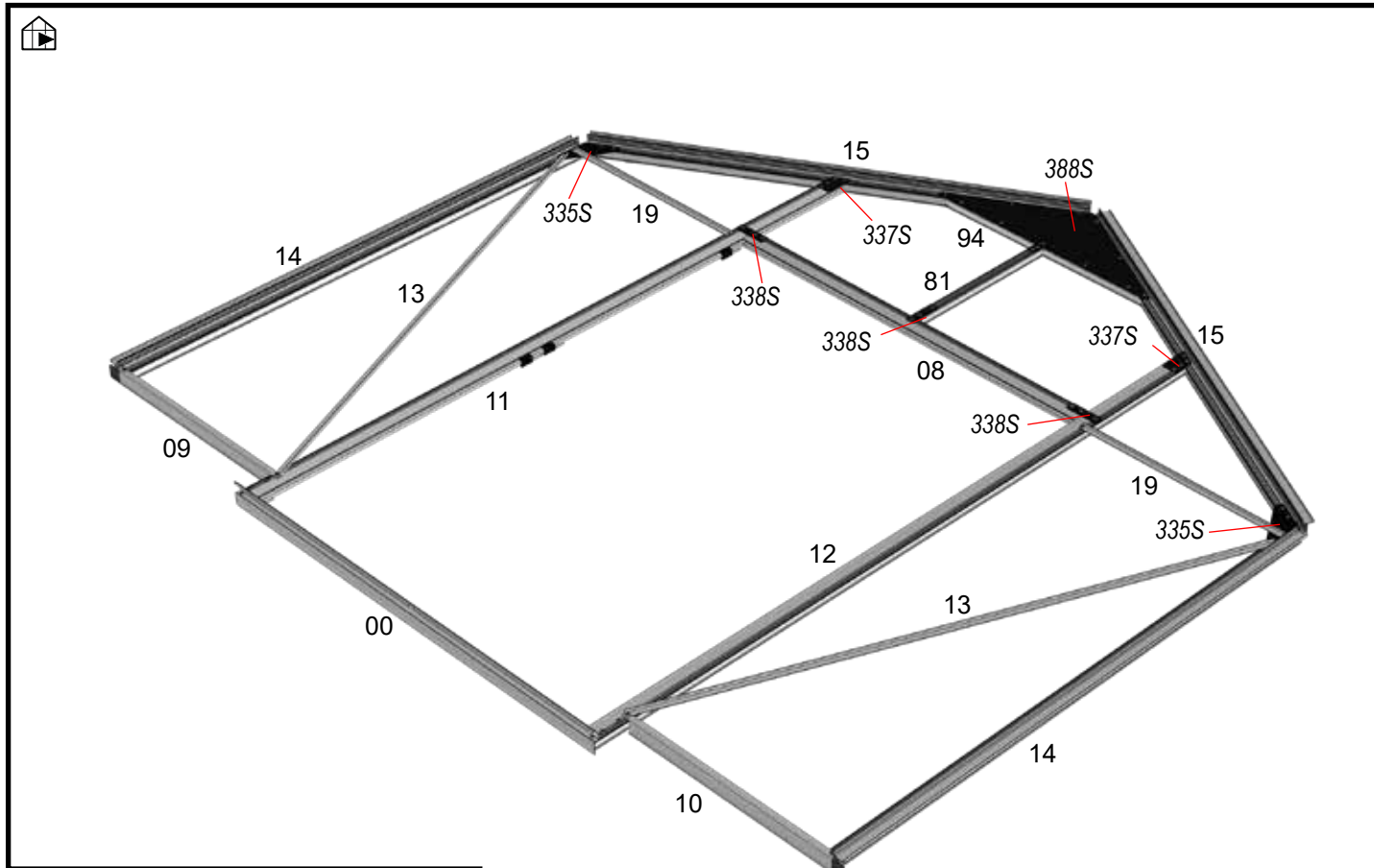









	#	mm	Qty
	F	740	2
	D	1468	1
	341S	345	1
	342S	345	1
	995	M6x10	12
	996	M6	12
	280	M6	8



Gavl - Gable - Giebel - Gavel - Pignon - Gevel - Päätty - Szczyt



	#	mm	Qty.
	00	1468	1
	08	1404	1
	09	742	1
	10	742	1
	11	2368	1
	12	2368	1
	19	730	2
	81	588	1
Fittings			
	05	-	4
	06	-	4
	616	M6	76
	617	M6X11	76
	280	M6	76
	337S	-	2
	338S	-	3

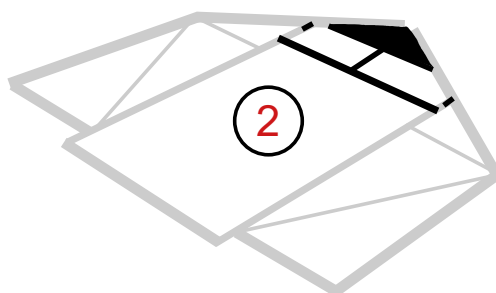
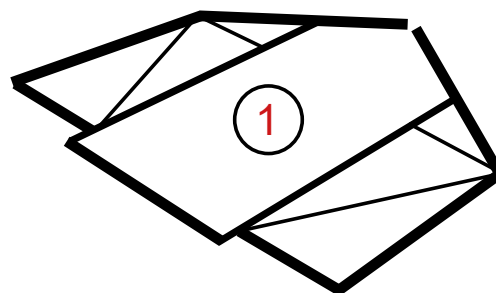

Gavl - Gable - Giebel - Gavel - Pignon - Gevel - Päätty - Szczyt

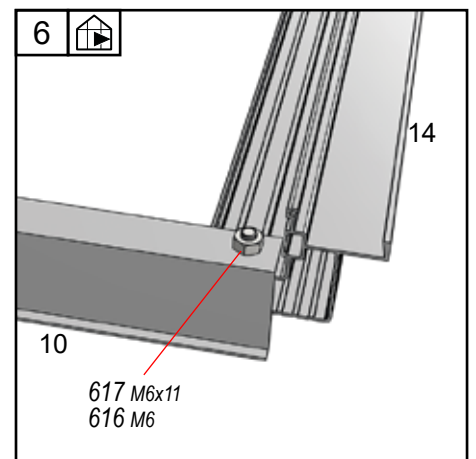
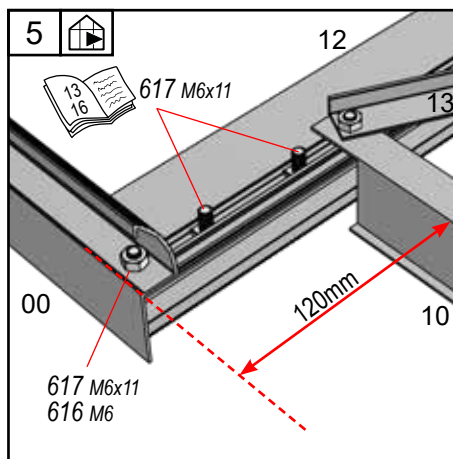
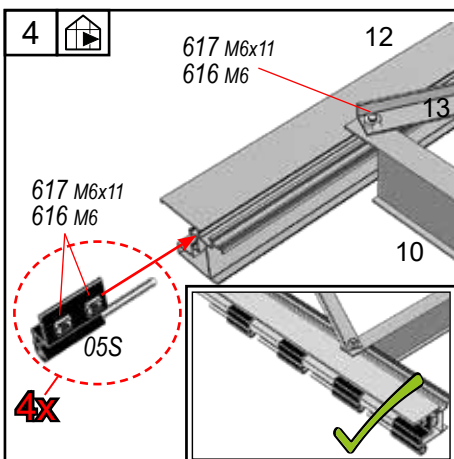
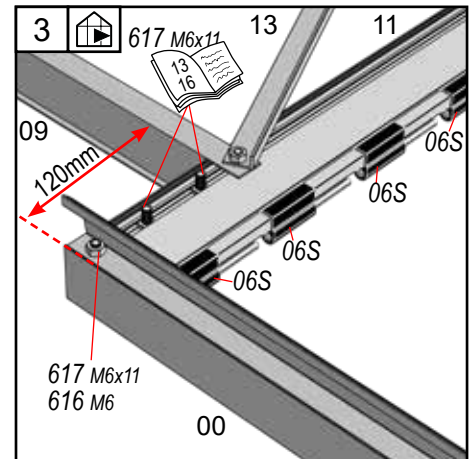
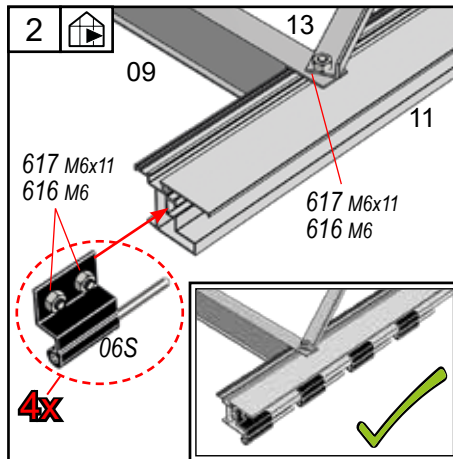
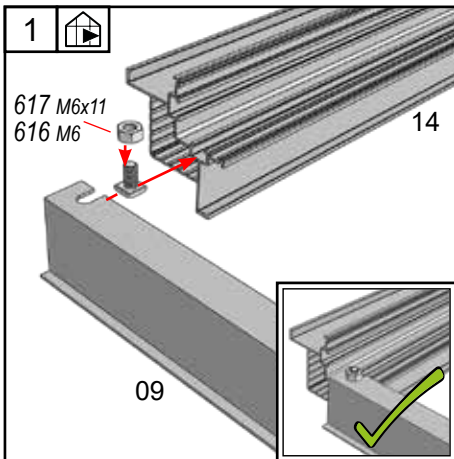
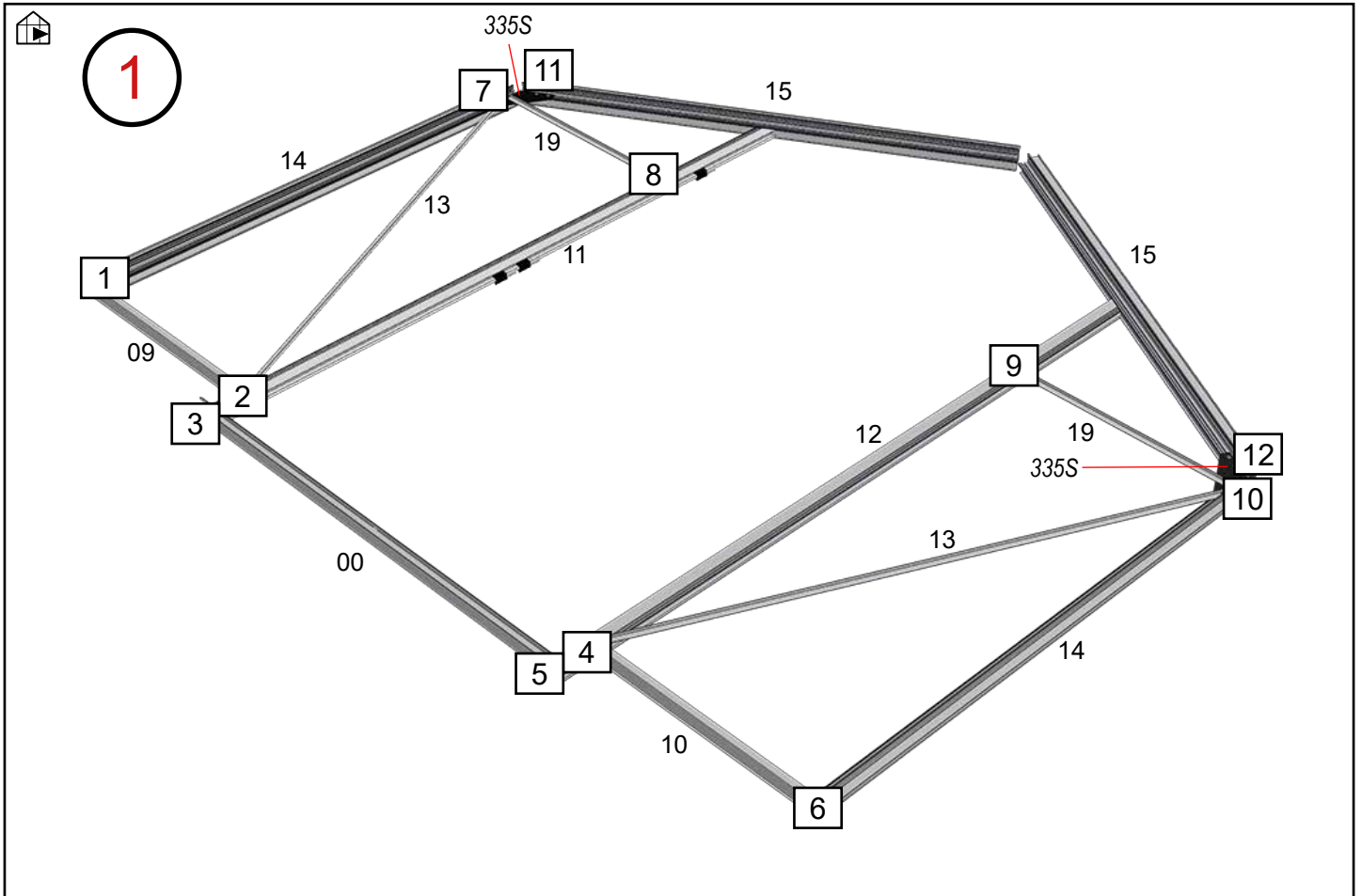

Gavl - Gable - Giebel - Gavel - Pignon - Gevel - Päätty - Szczyt

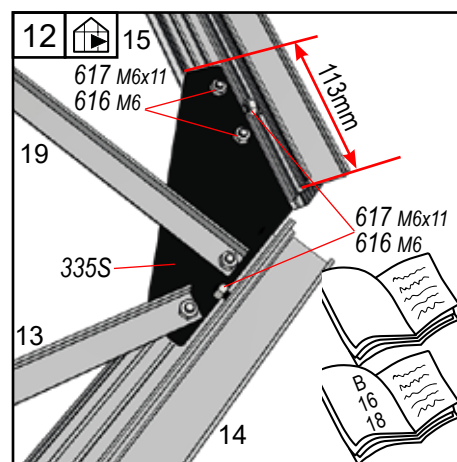
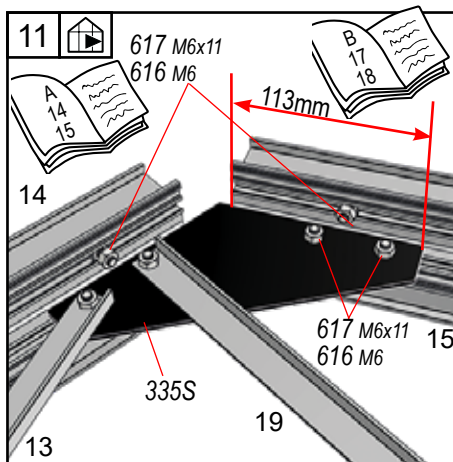
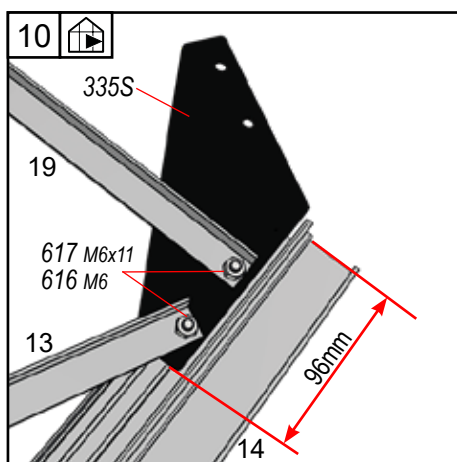
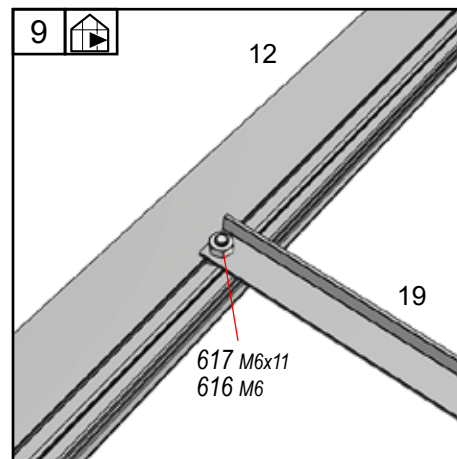
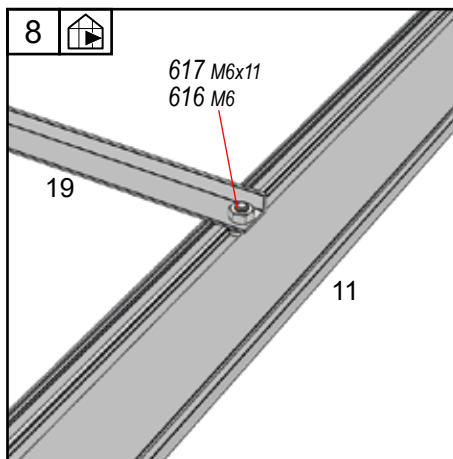
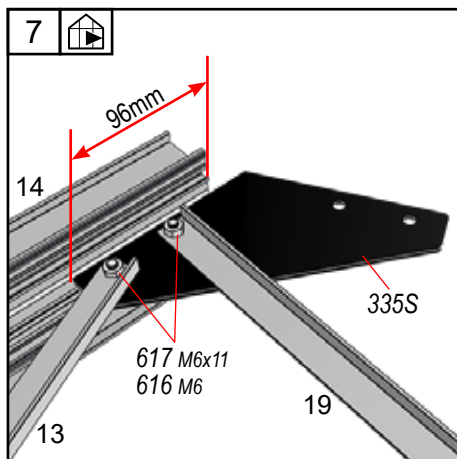

A



B



Gavl - Gable - Giebel - Gavel - Pignon - Gevel - Päätty - Szczyt

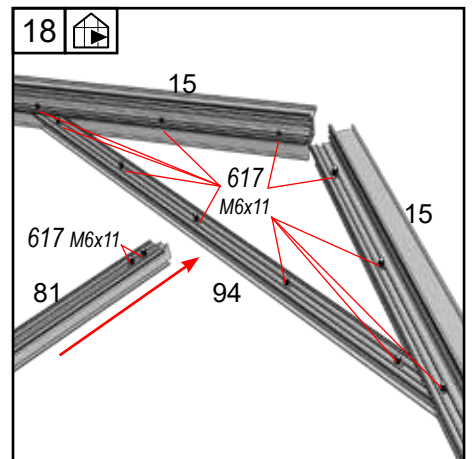
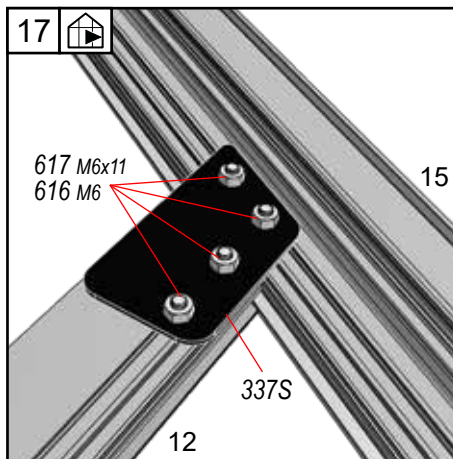
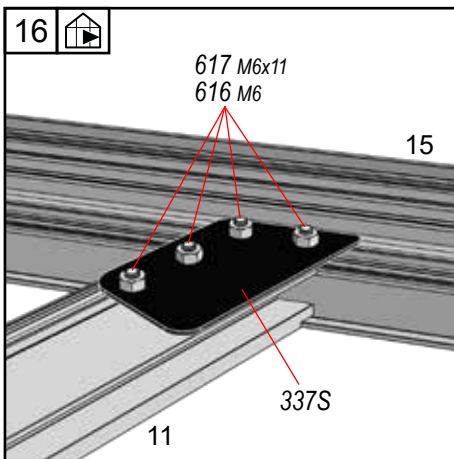
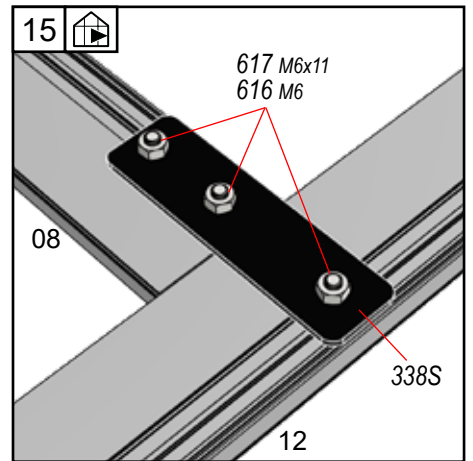
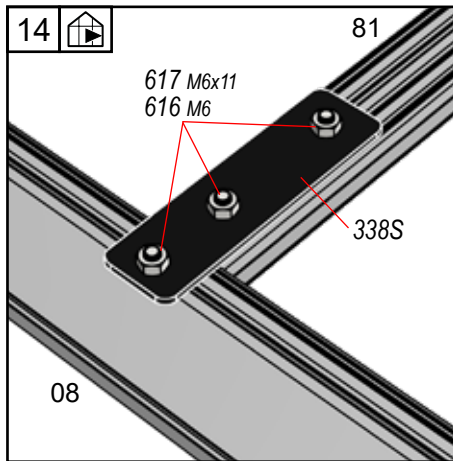
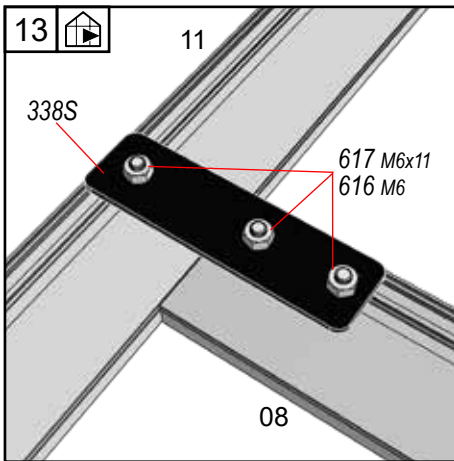
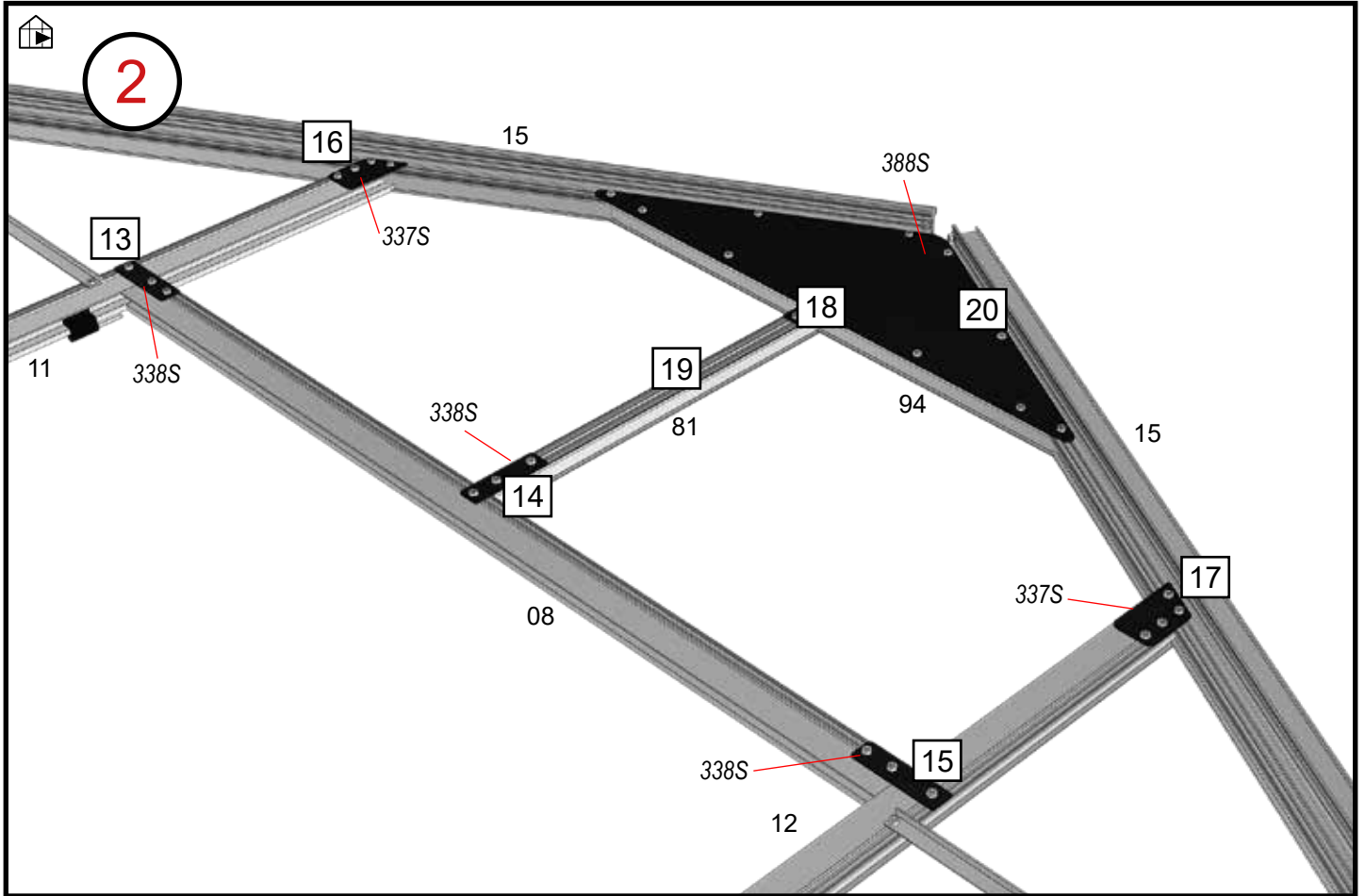

Gavl - Gable - Giebel - Gavel - Pignon - Gevel - Päätty - Szczyt

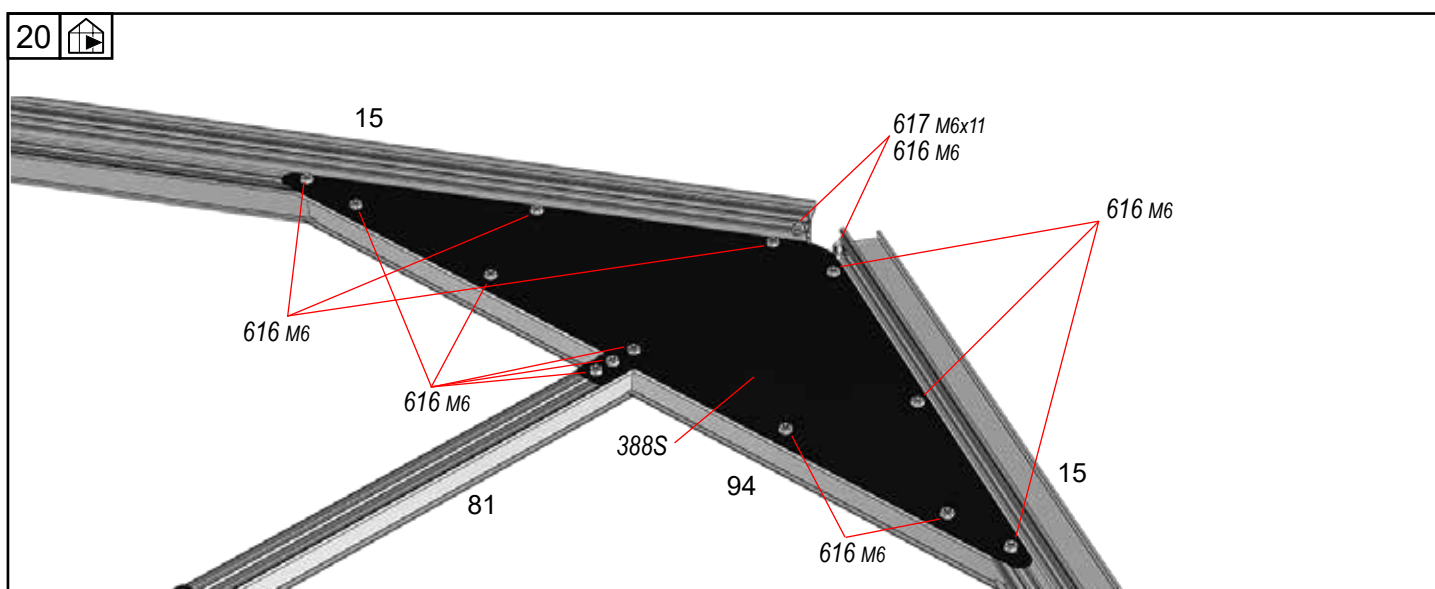
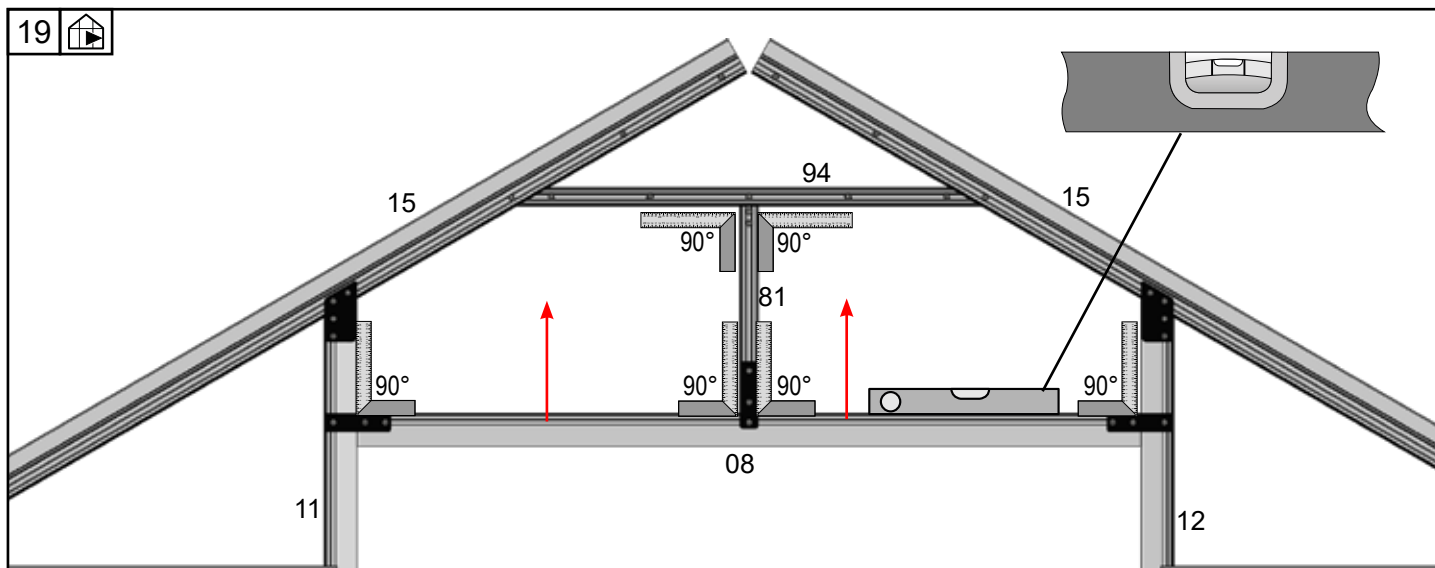

For - Front - Vorder - Front - Devant - Voor - Ovi - Przednia
Side - Seite - Sida - Côté - Pagina - Puoli - Strona



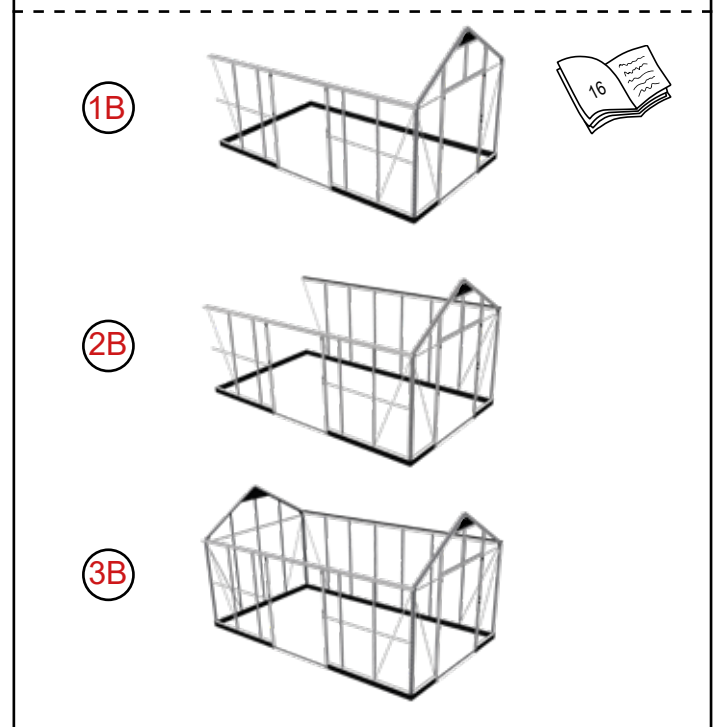
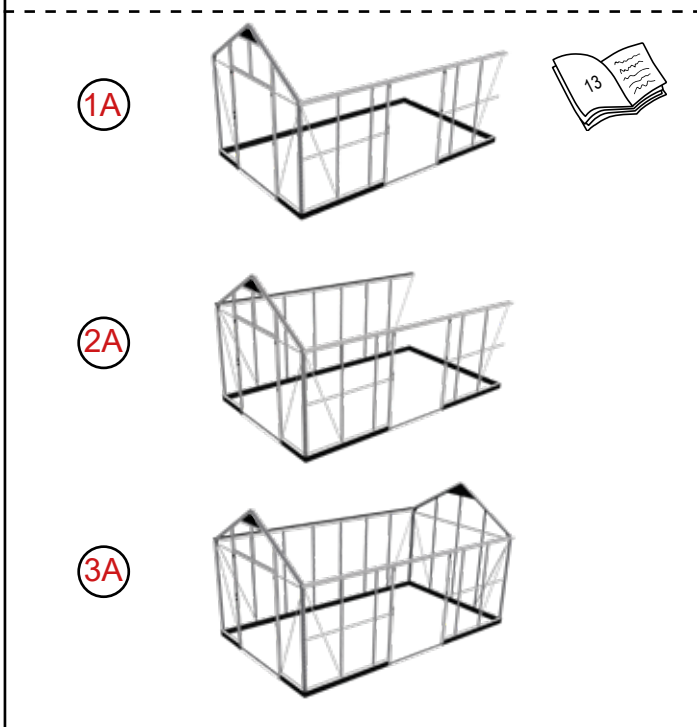
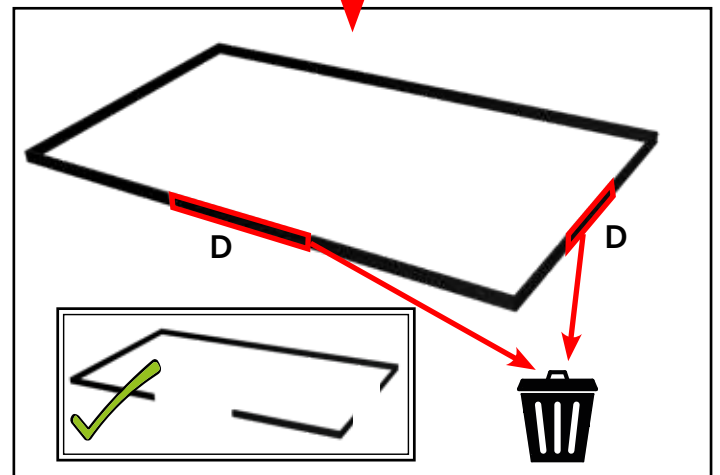
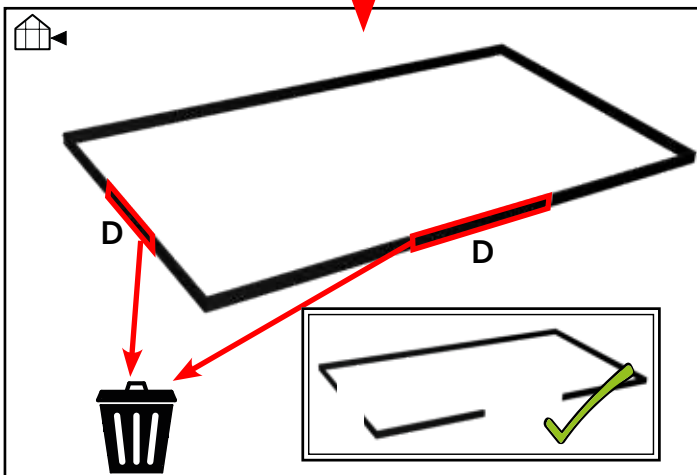
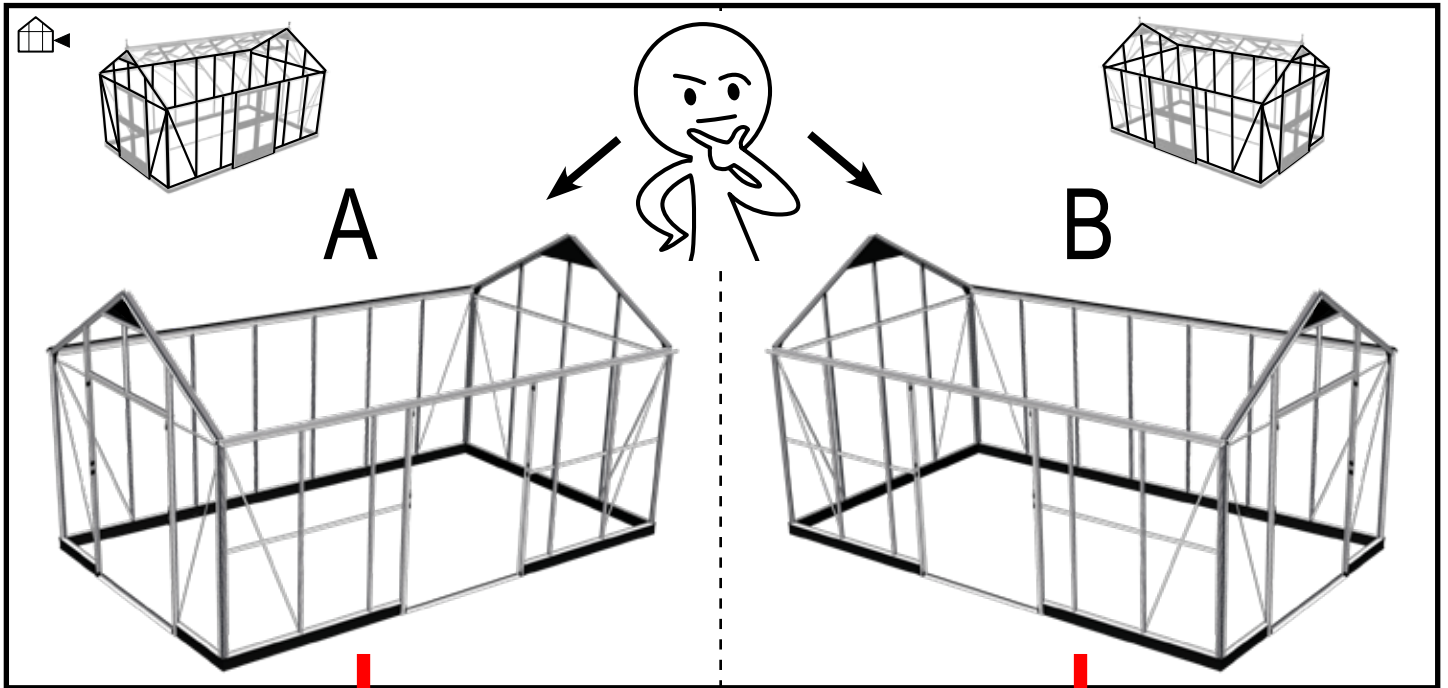

Samling - Assembly - Verbindung - Församling - Assemblage -
Kokoaminen - Montaž stelaža

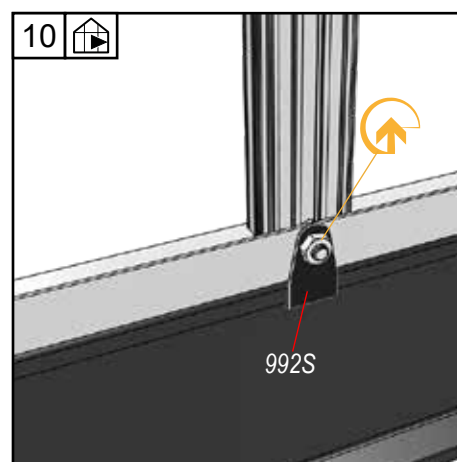
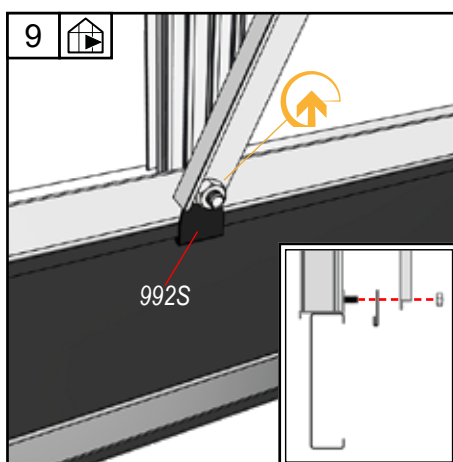
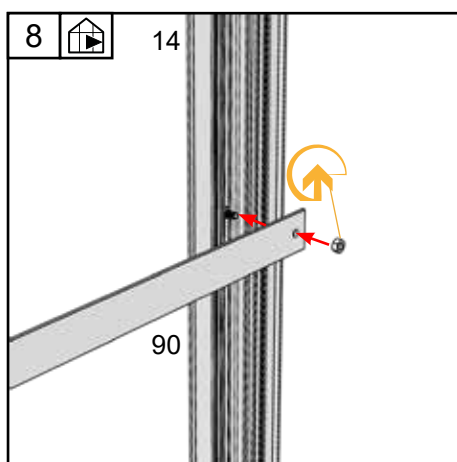
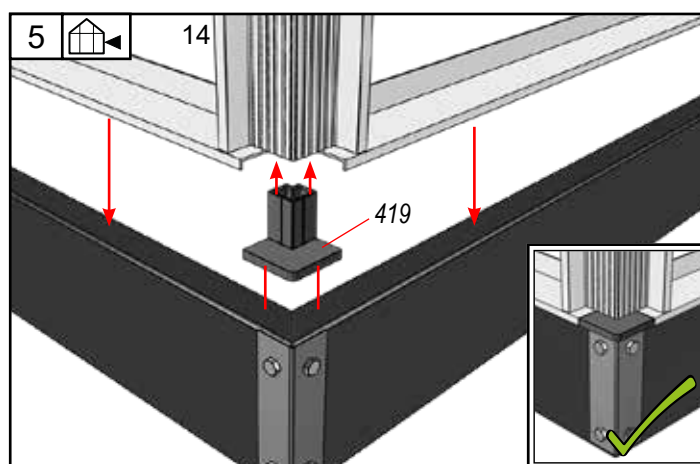
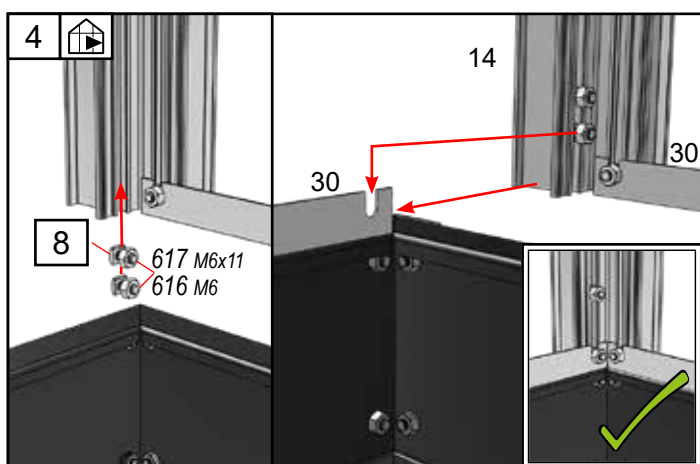
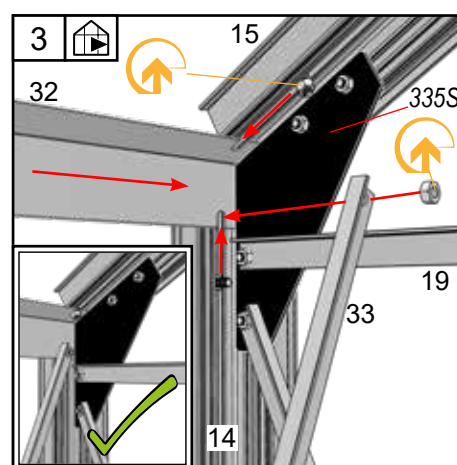
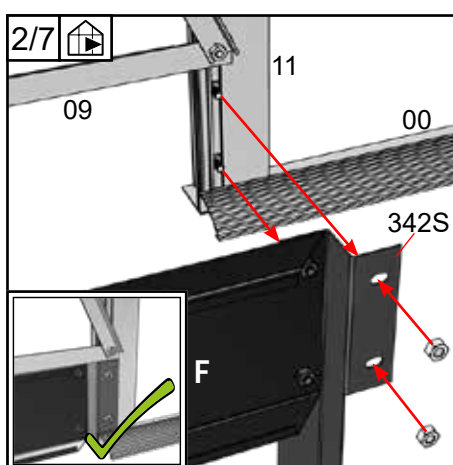
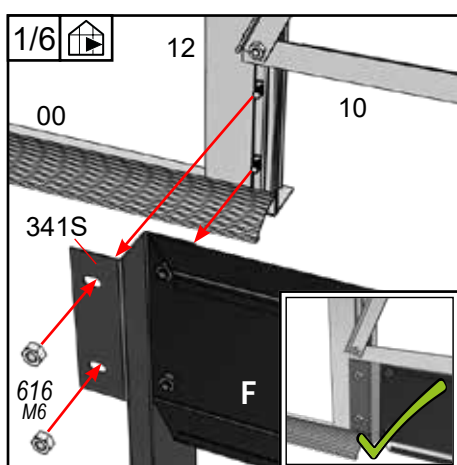
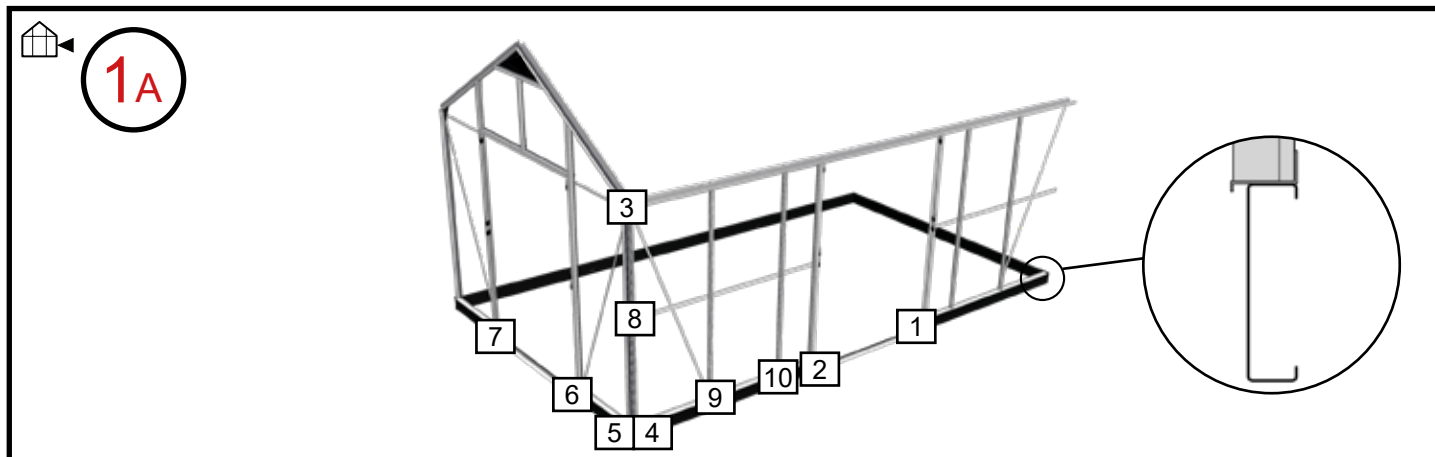

Samling - Assembly - Verbindung - Församling - Assemblage -
Kokoaminen - Montaż stelaża

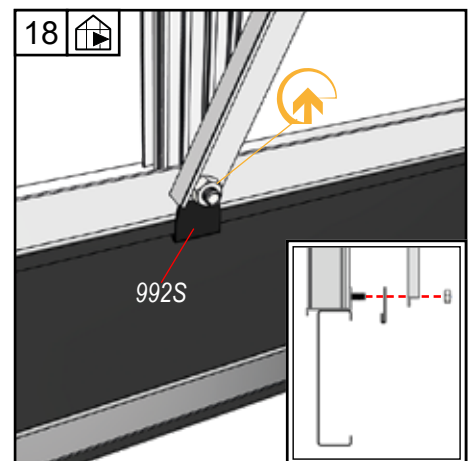
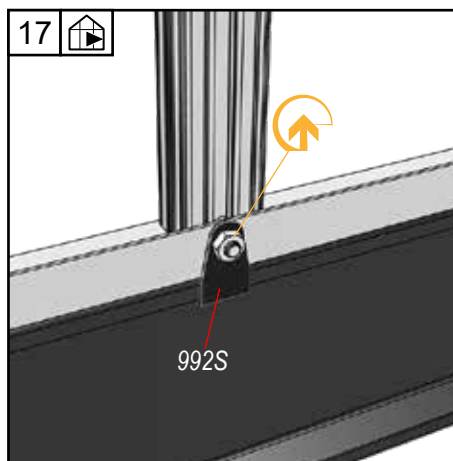
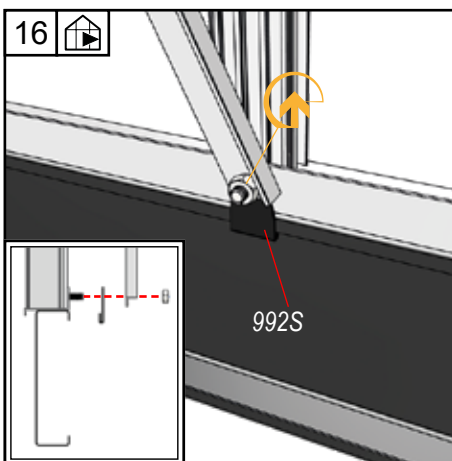
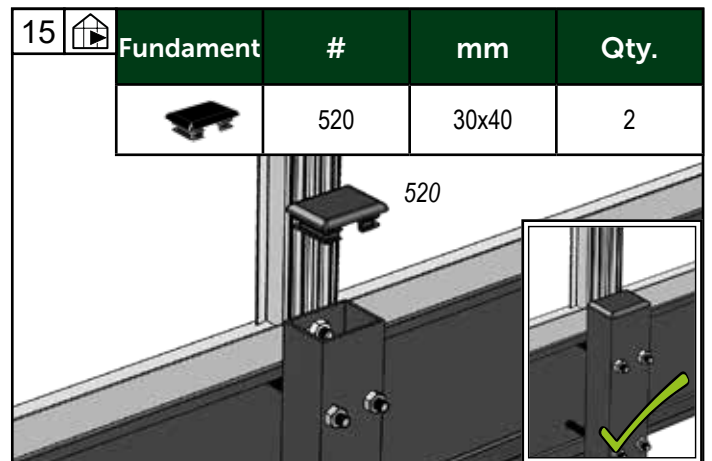
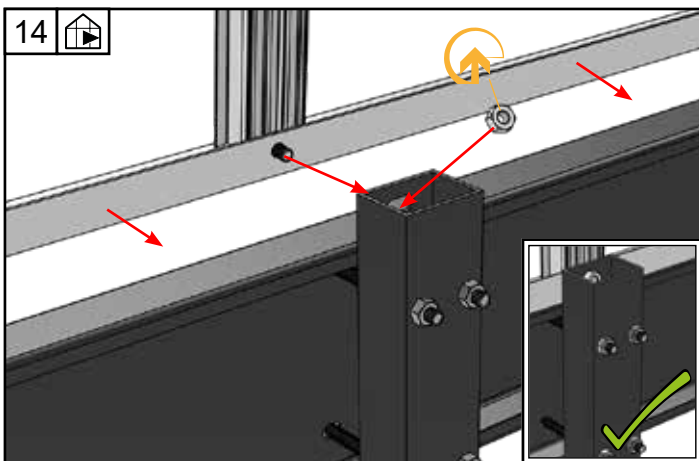
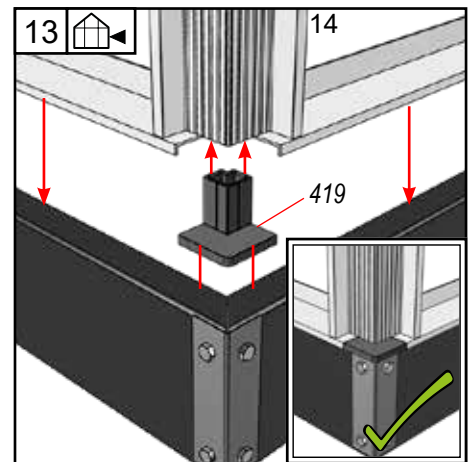
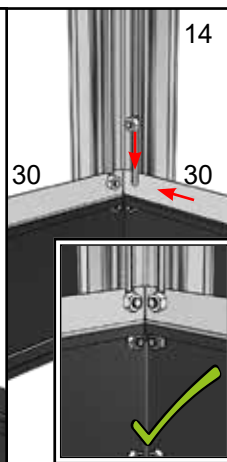
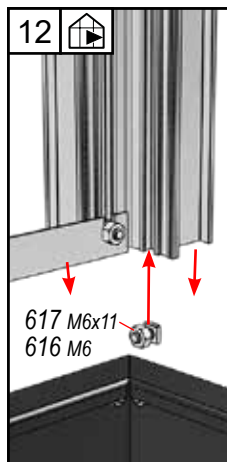
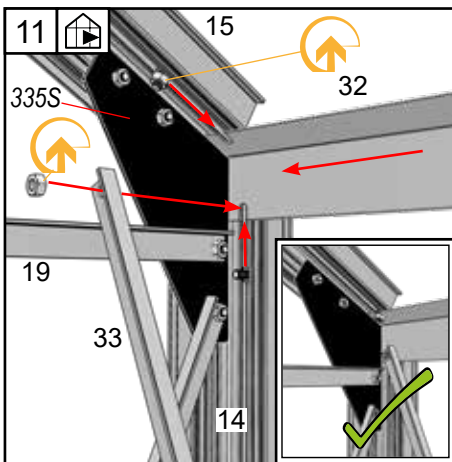
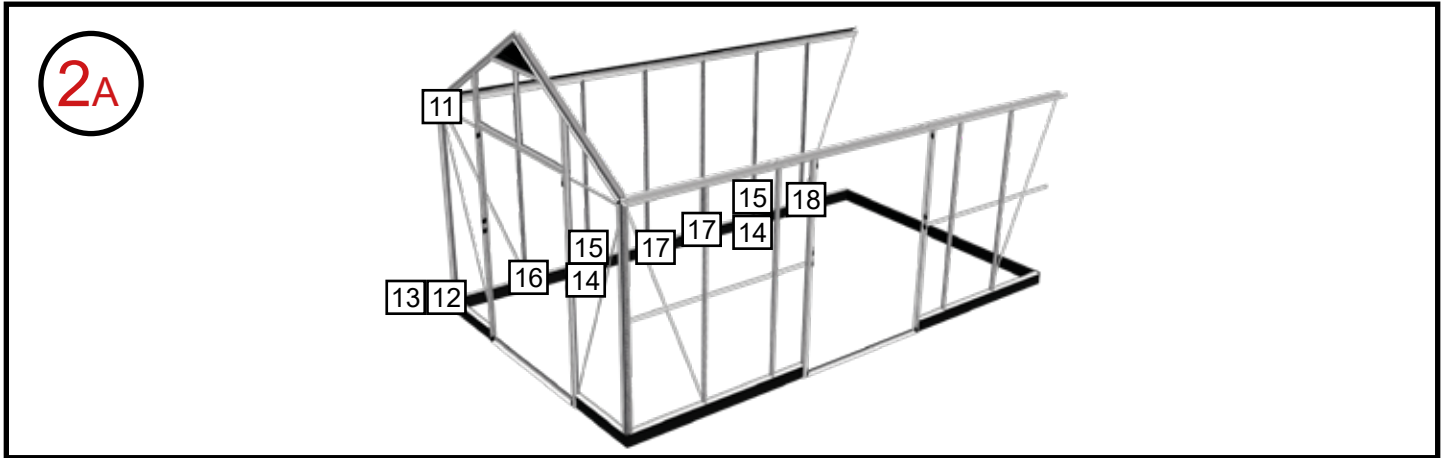

Samling - Assembly - Verbindung - Församling - Assemblage -
Kokoaminen - Montaž stelaža

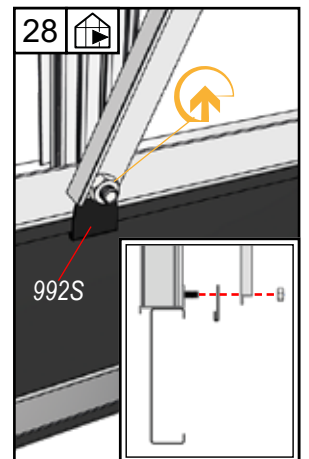
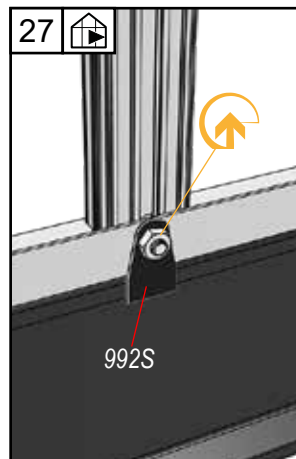
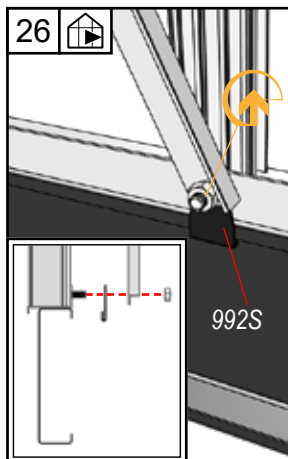
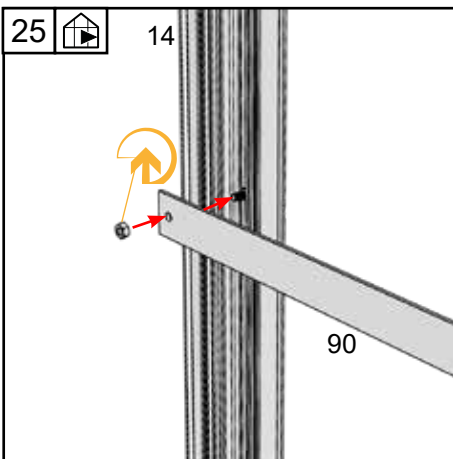
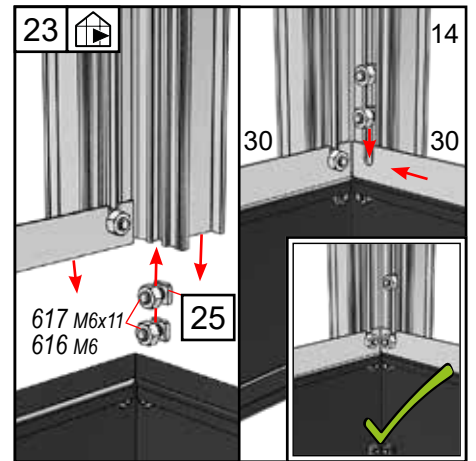
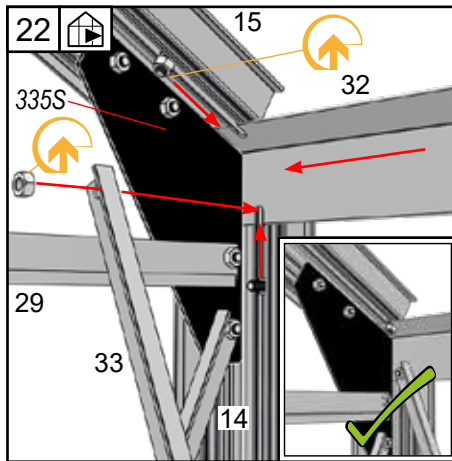
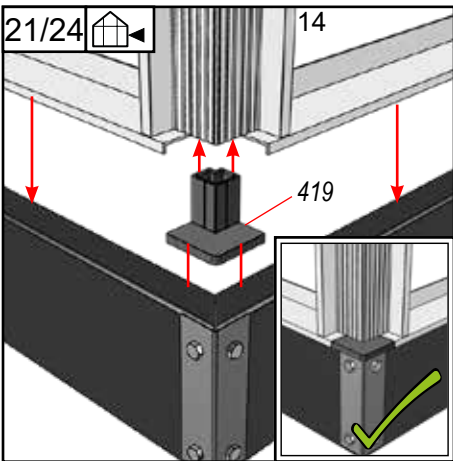
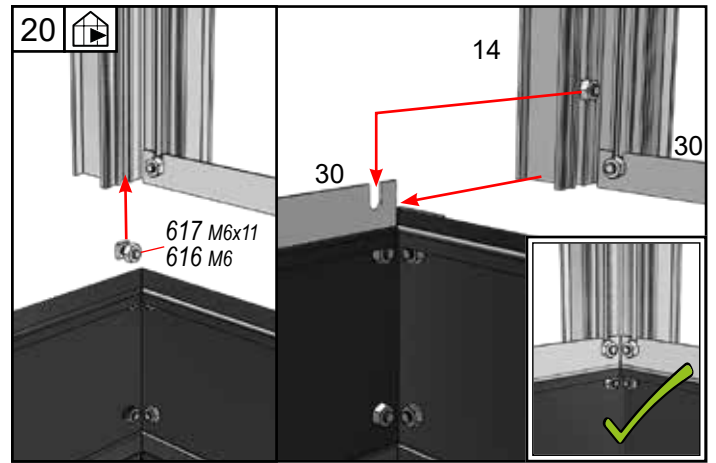
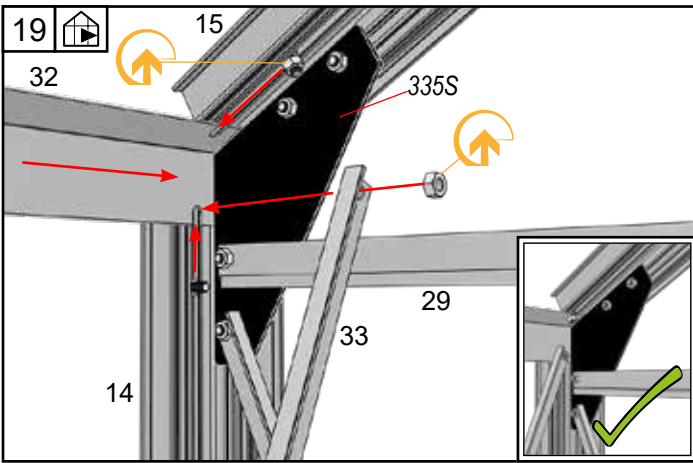
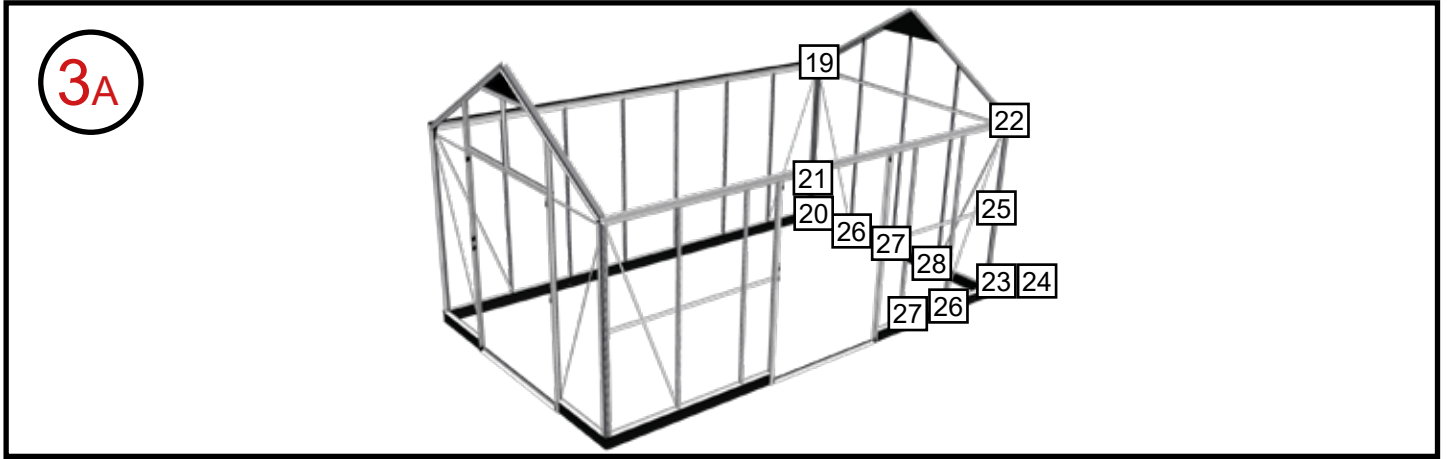

Samling - Assembly - Verbindung - Församling - Assemblage -
Kokoaminen - Montaž stelaža

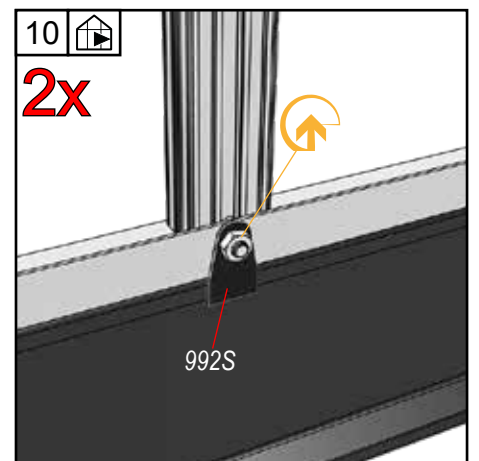
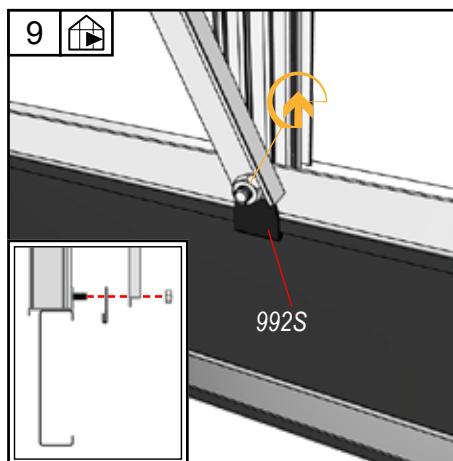
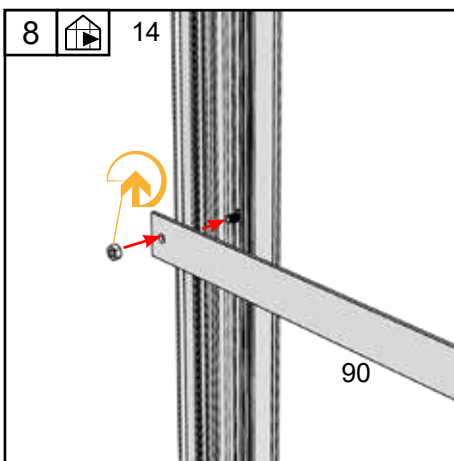
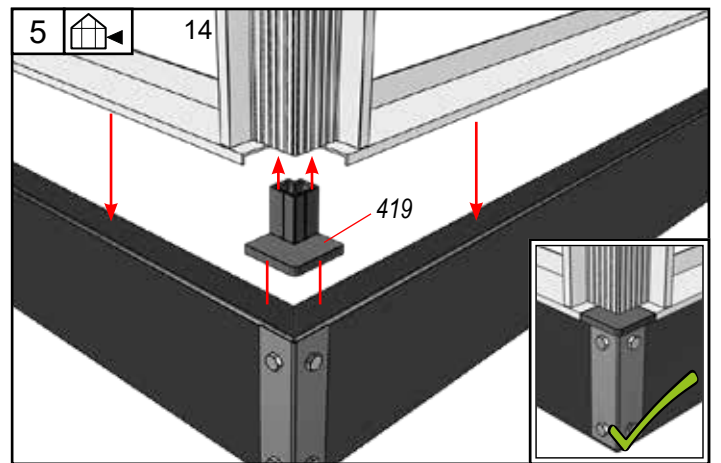
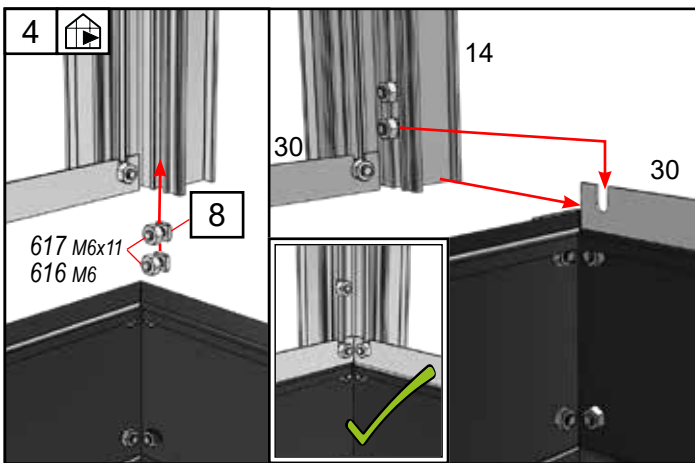
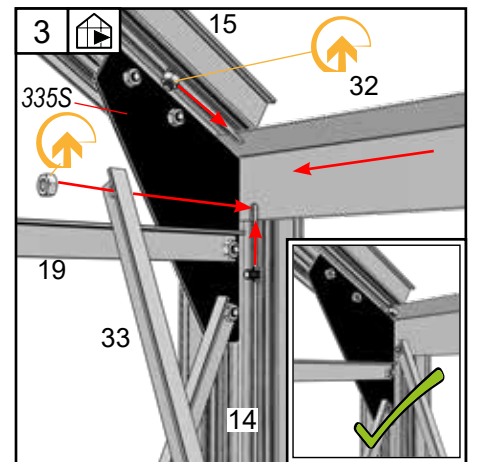
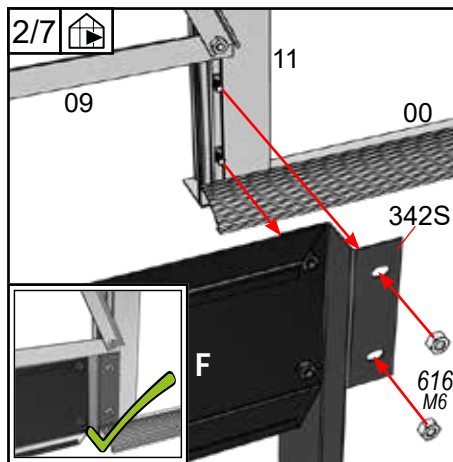
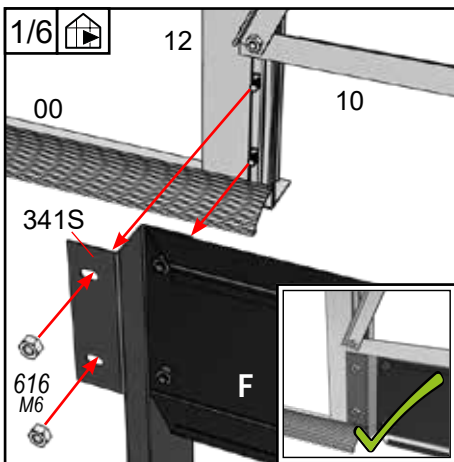
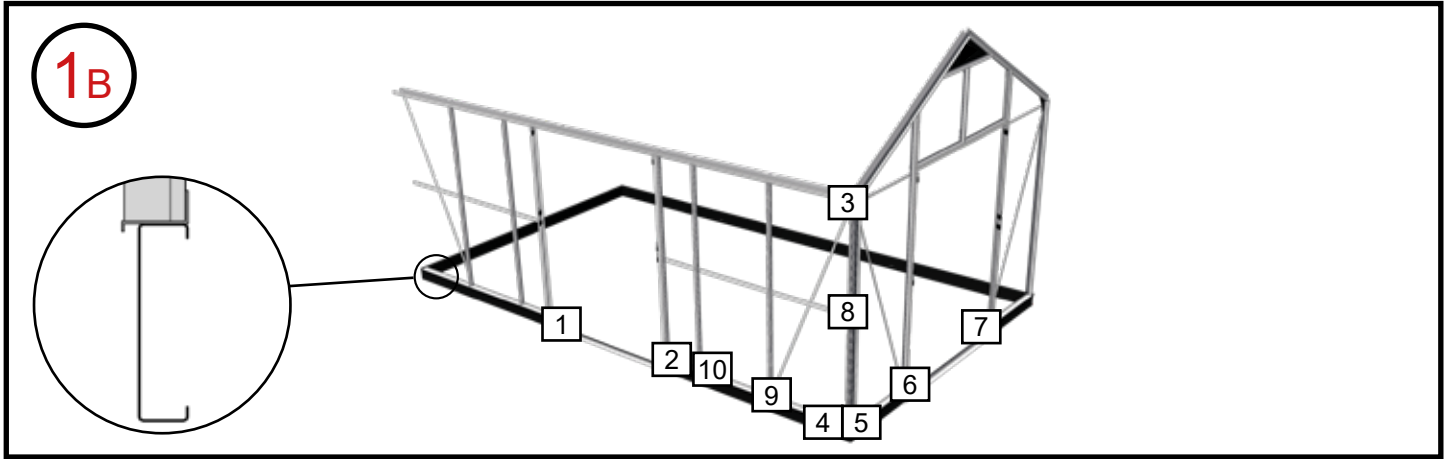

Samling - Assembly - Verbindung - Församling - Assemblage -
Kokoaminen - Montaž stelaža

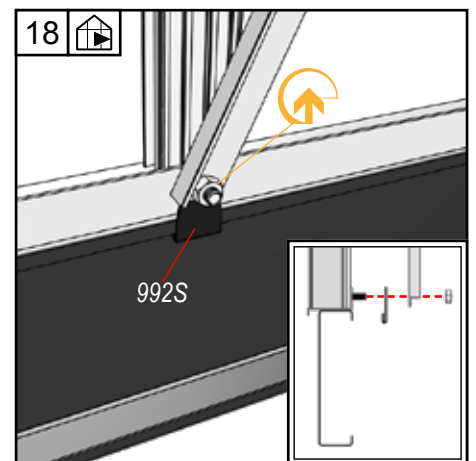
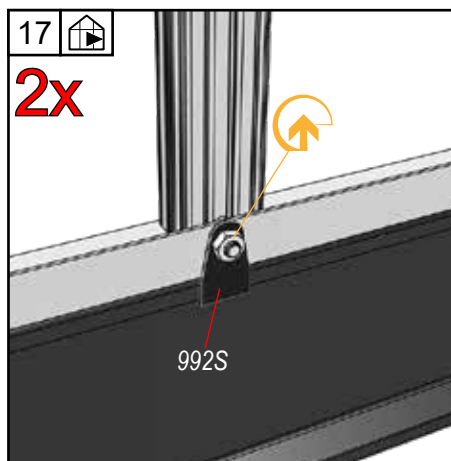
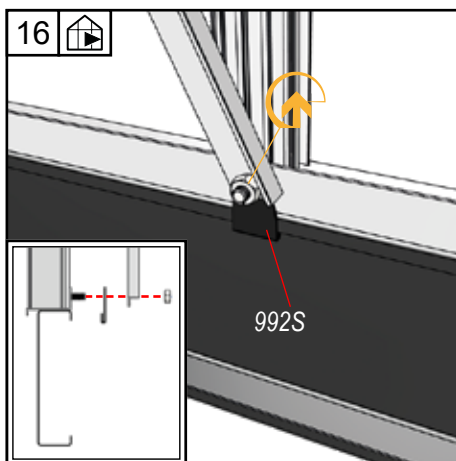
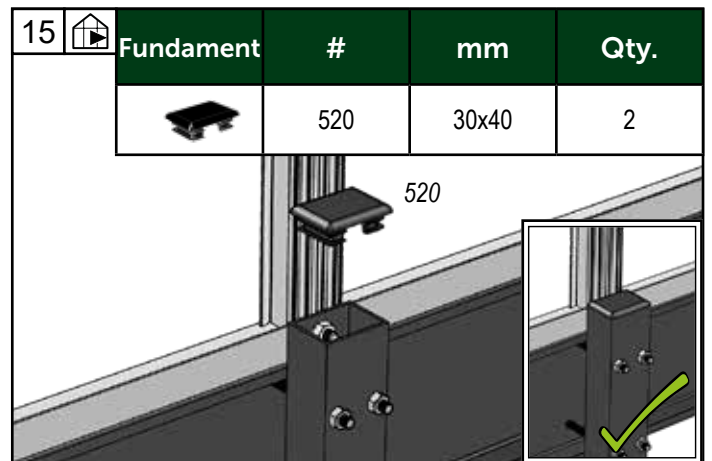
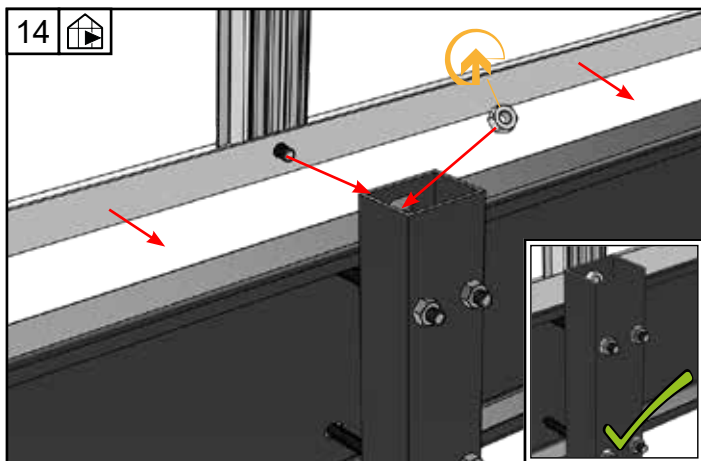
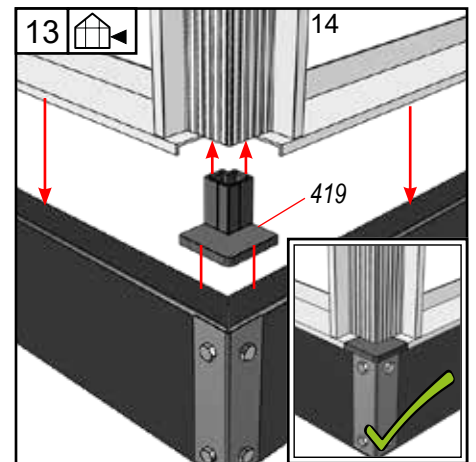
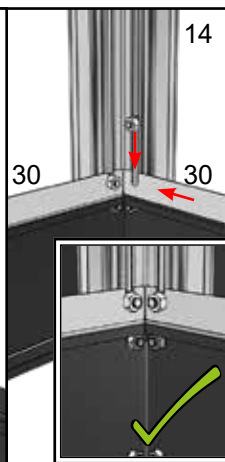
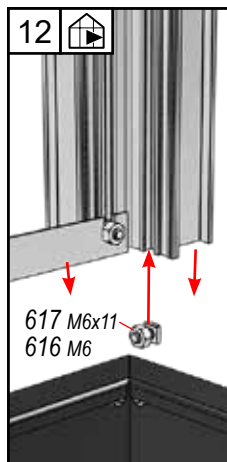
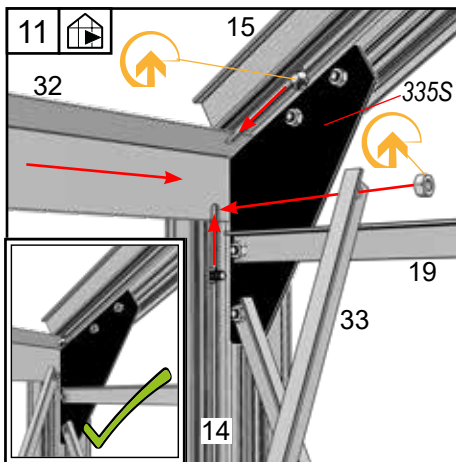
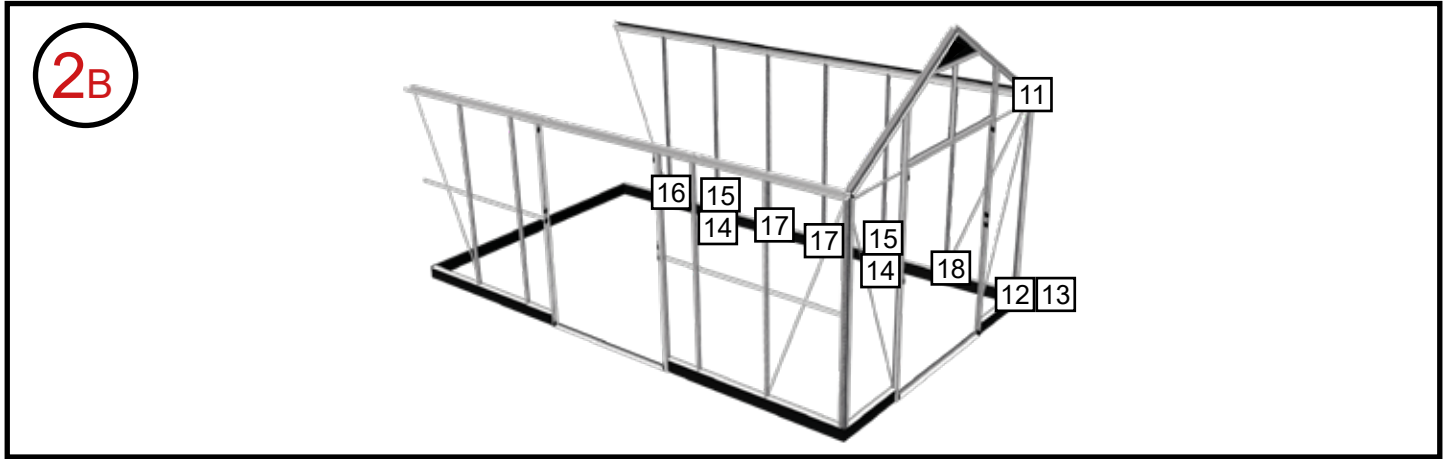

Samling - Assembly - Verbindung - Församling - Assemblage -
Kokoaminen - Montaž stelaža

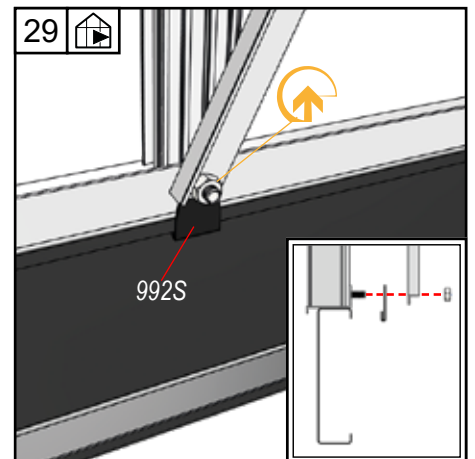
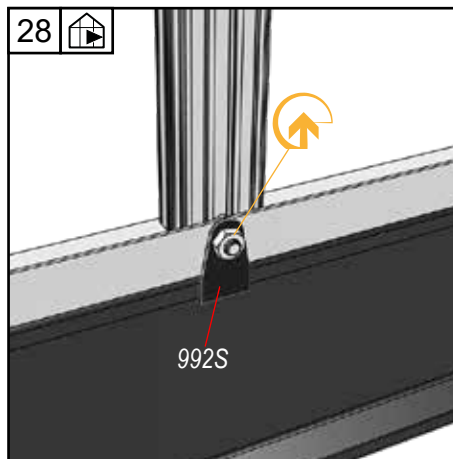
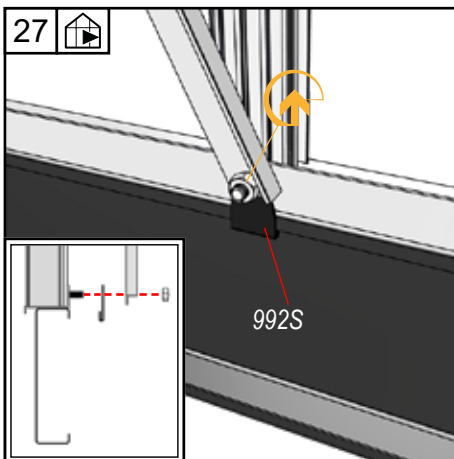
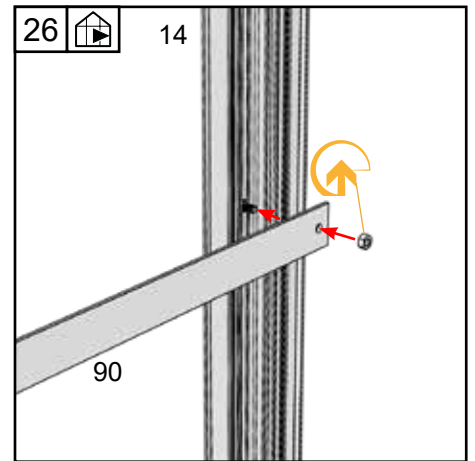
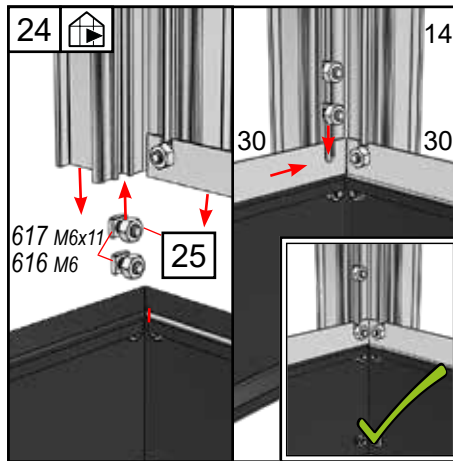
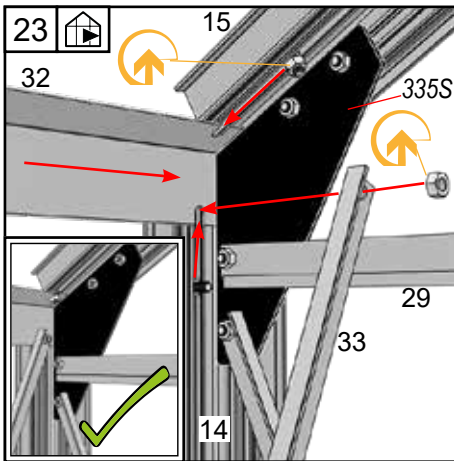
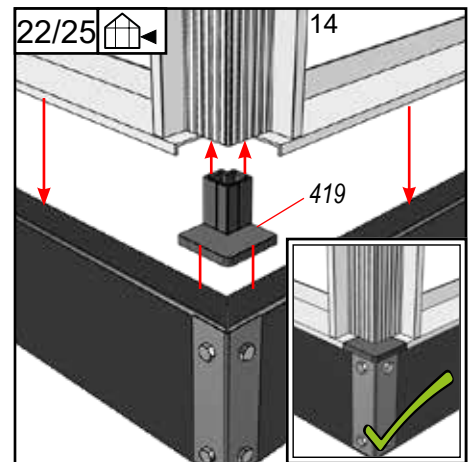
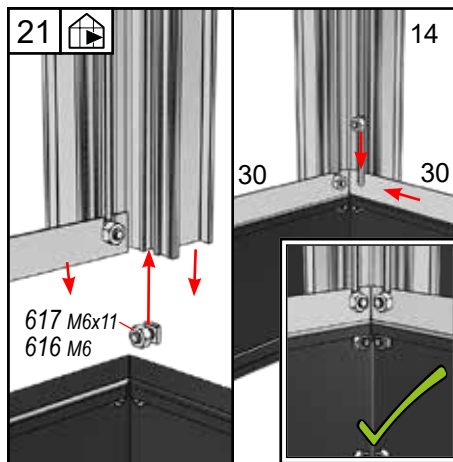
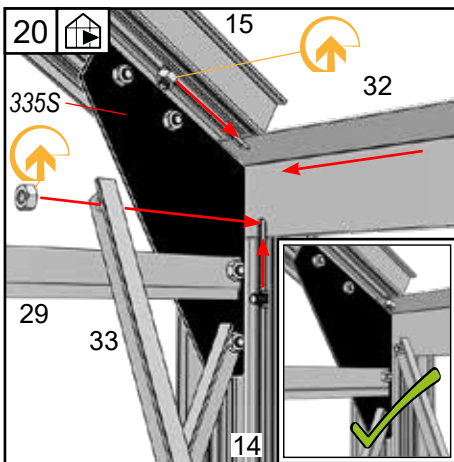
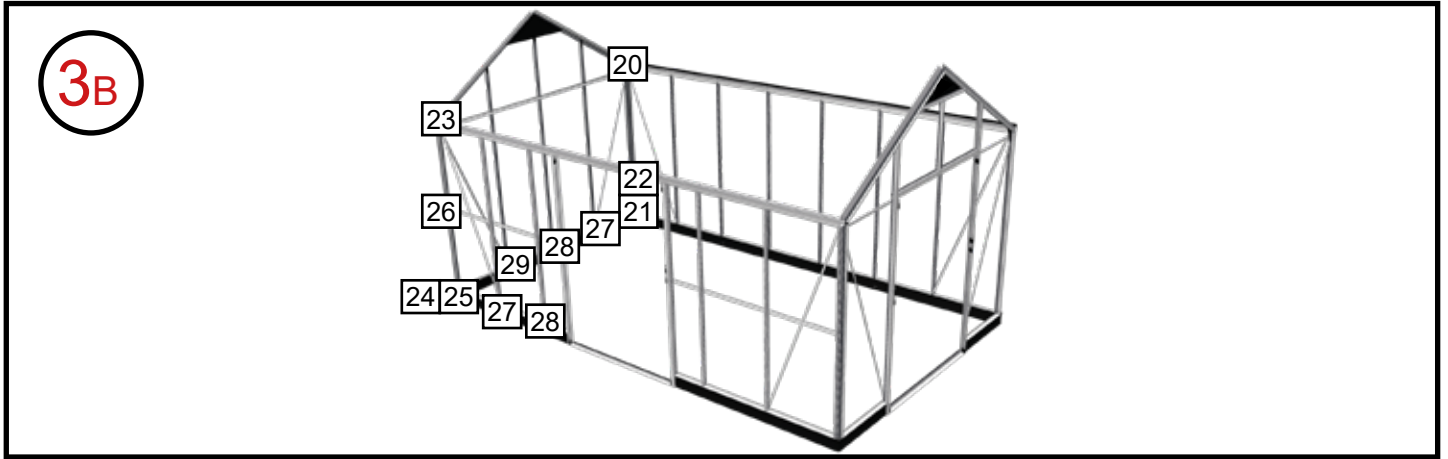

Tag - Roof - Dach - Tak - Toit - Dak - Katto



3 mm - Hærdet glas - Toughened glass - Sicherheitsglas (ESG) - Säkerhetsglas - Verre Trempé - Gehard Glas - Karkaistu Turvalasi - Szkło Hartowane

BOX 11	#	mm	Qty		#	mm	Qty
	M2465	2465	6		G	517x700	2
					H	578x700	2
					I	691X574 (574/394/400)	2

Samling - Assembly - Verbindung - Församling - Assemblage - Kokoaminen - Montaž stelaža

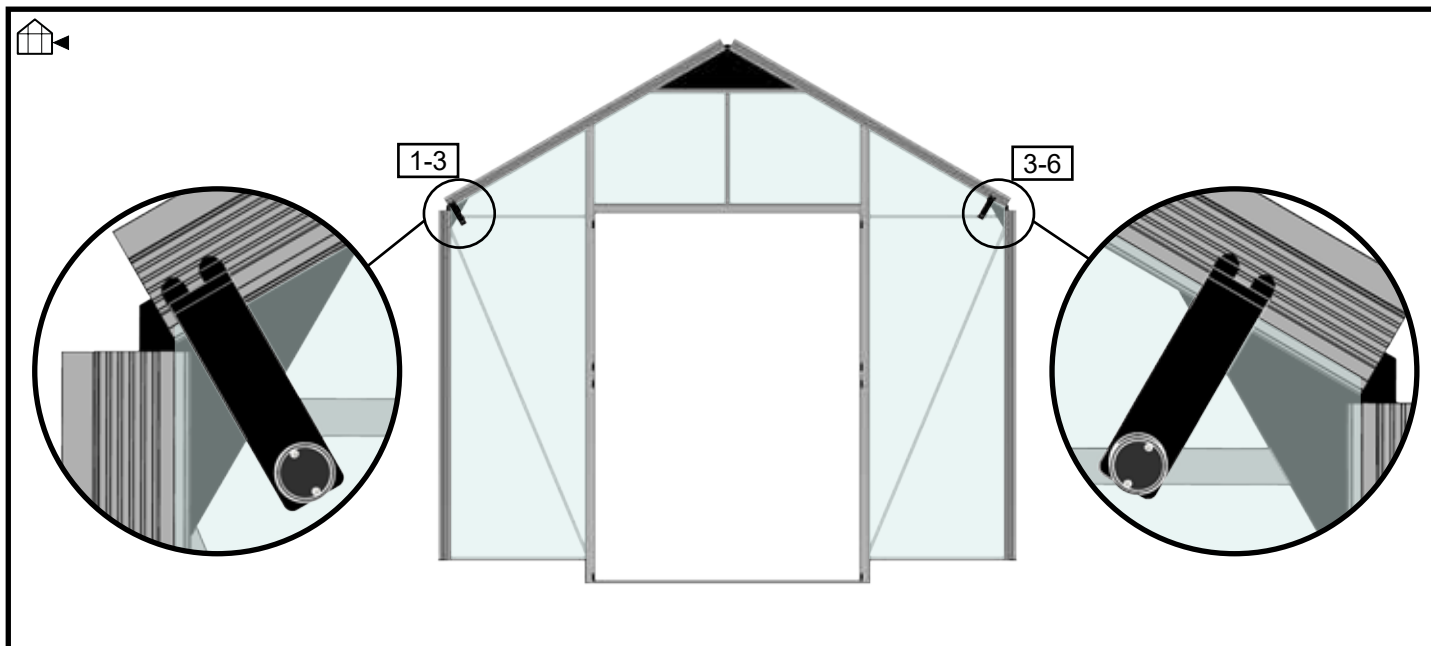

	#	mm	Qty.
	392S	-	2
	470	-	4
	668	M4 x 16	4
	669	M4	4

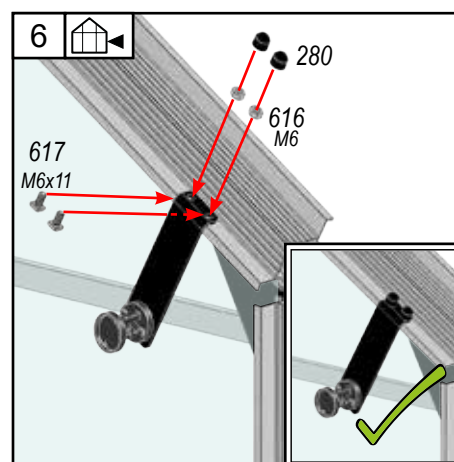
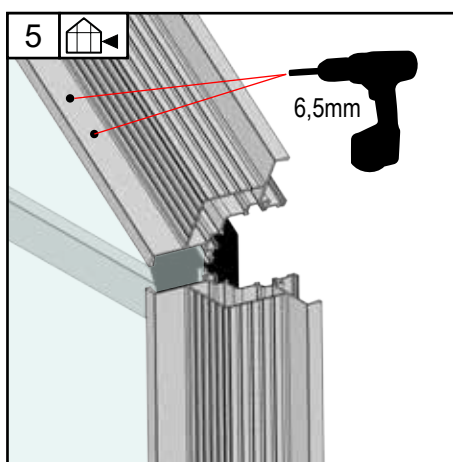
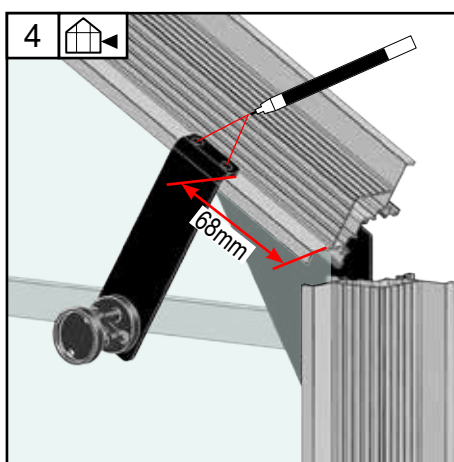
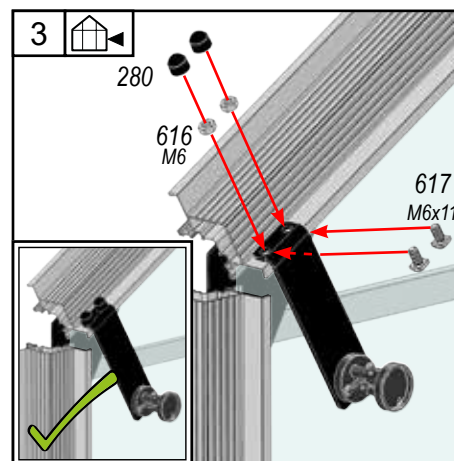
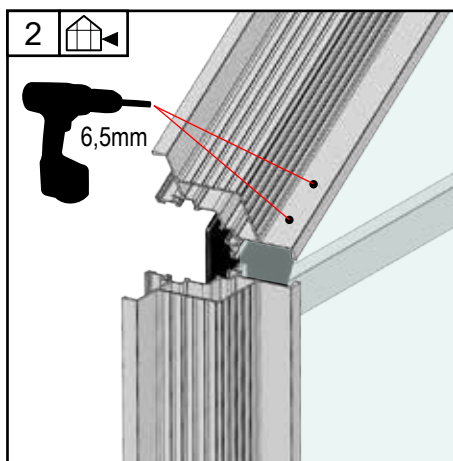
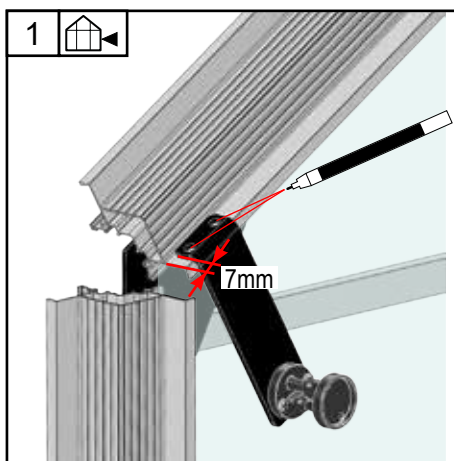
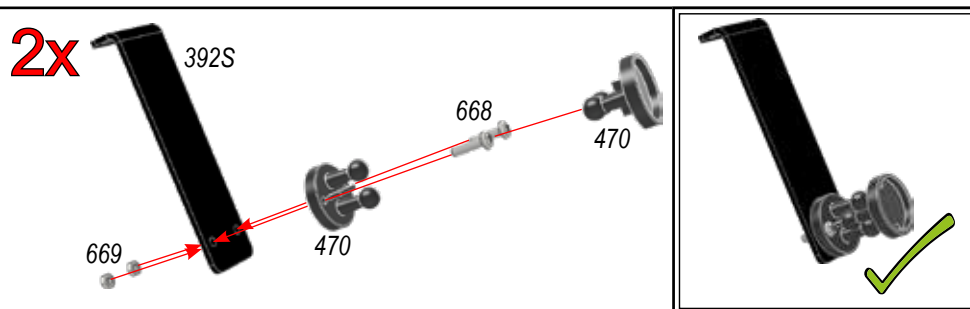



Dør - Door - Tür - Dörr - Porte - Deur - Ovi - Drzwi

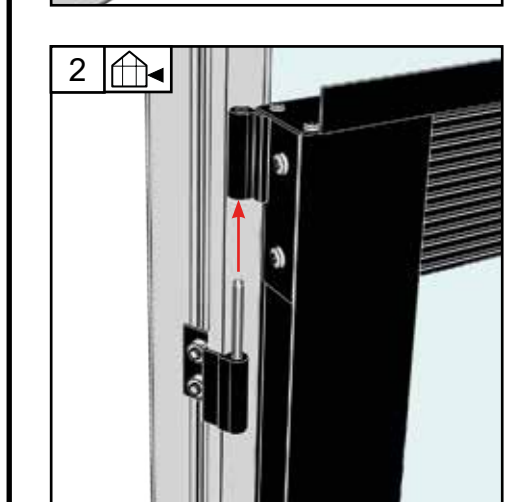
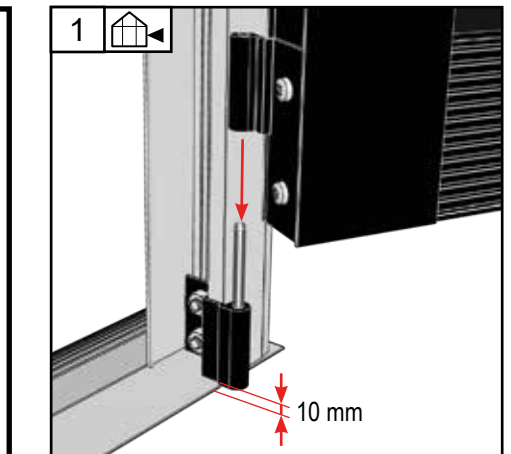
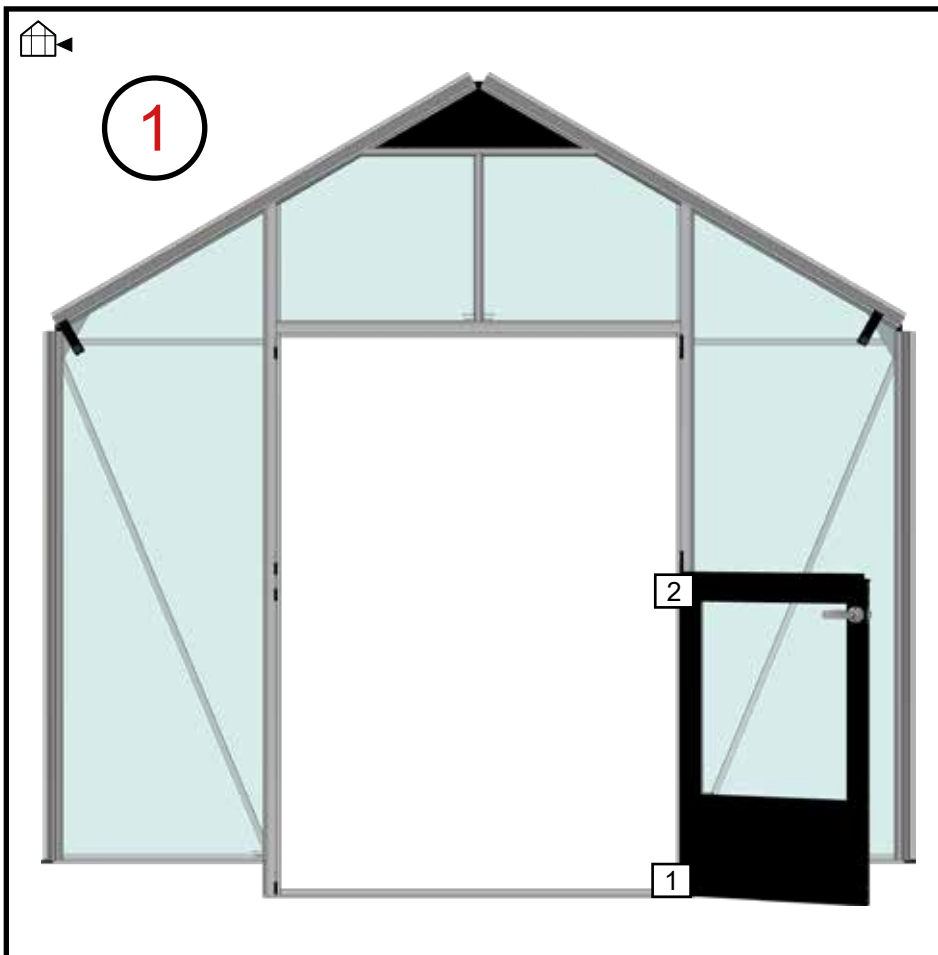
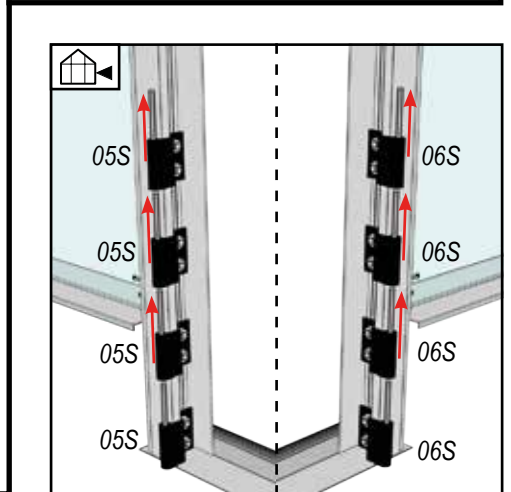
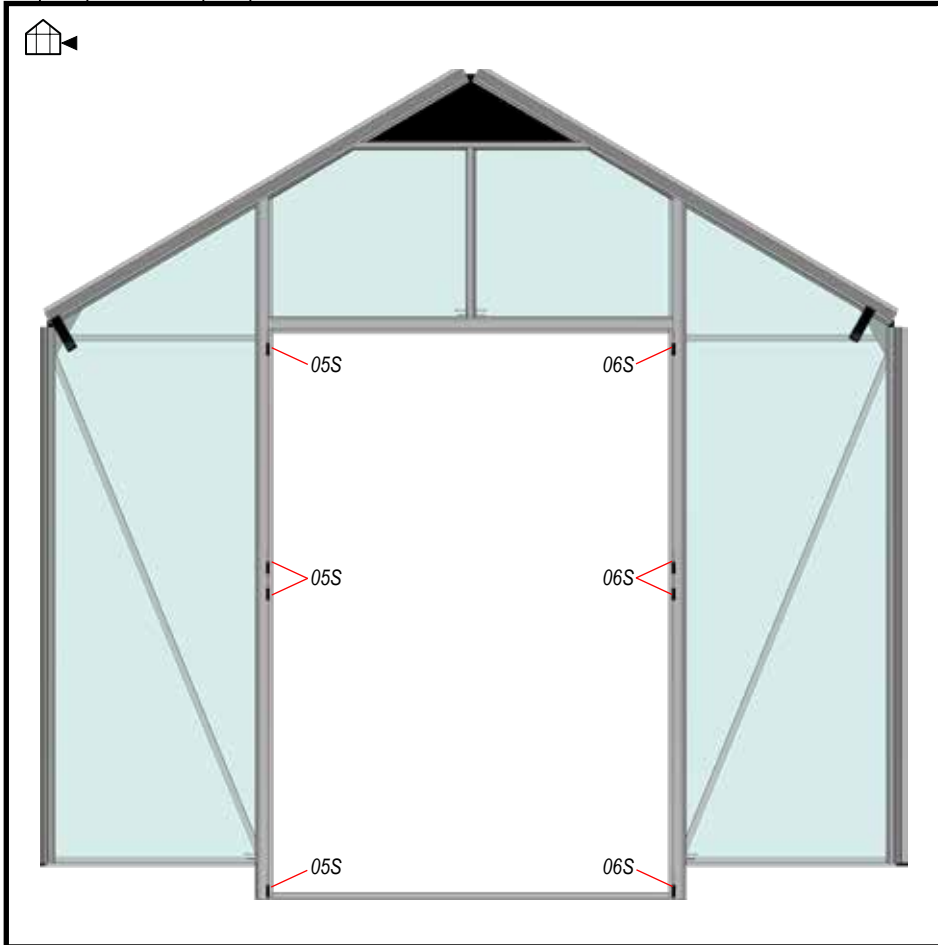

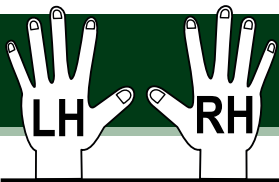

Dør - Door - Tür - Dörr - Porte - Deur - Ovi - Drzwi

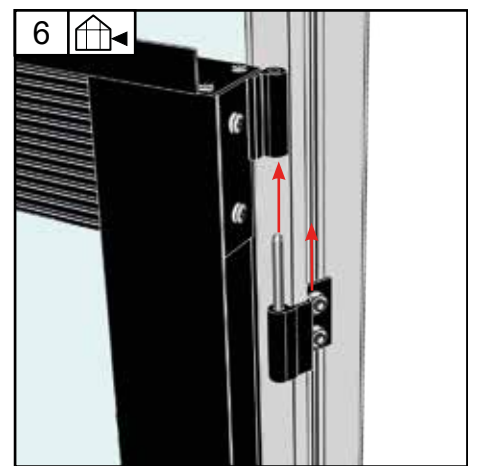
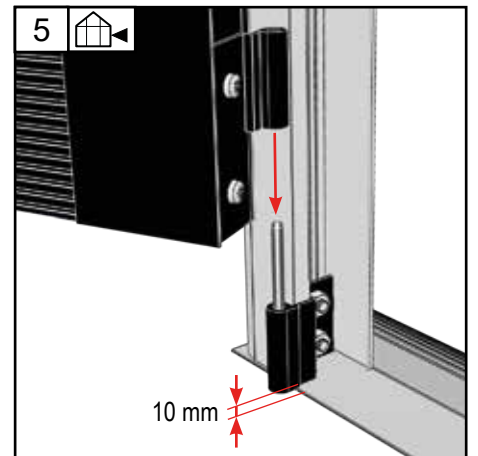
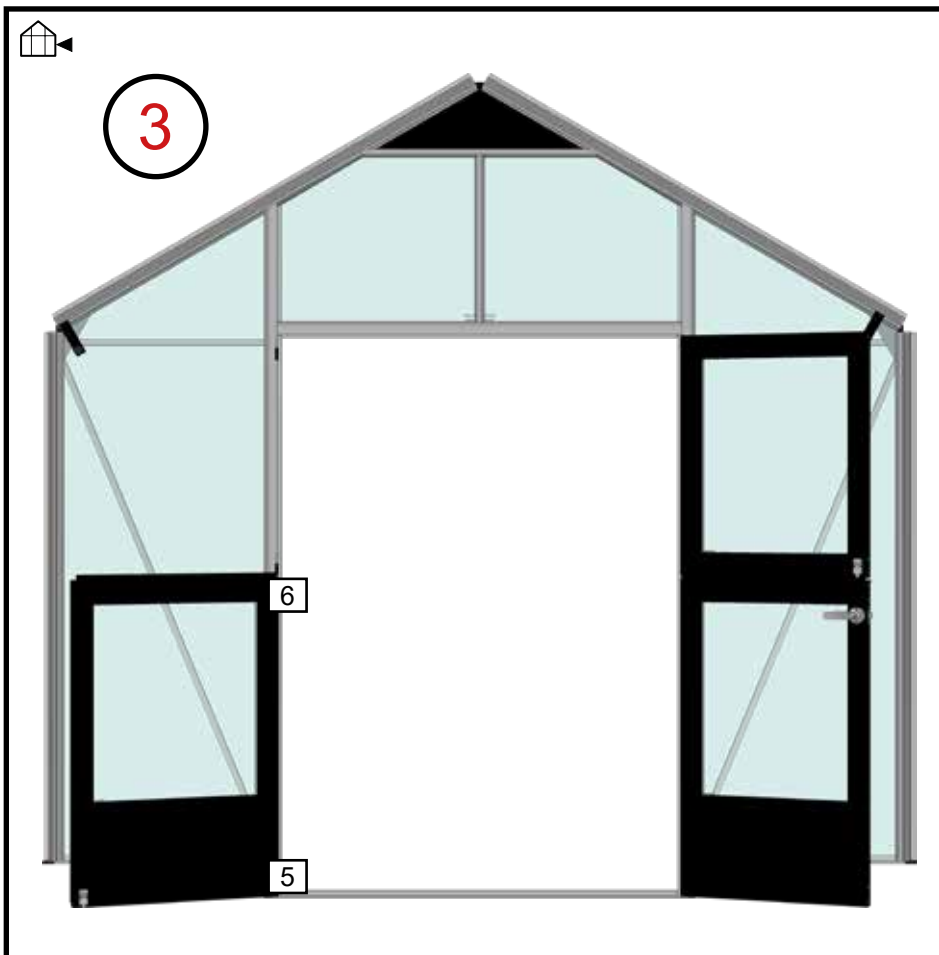
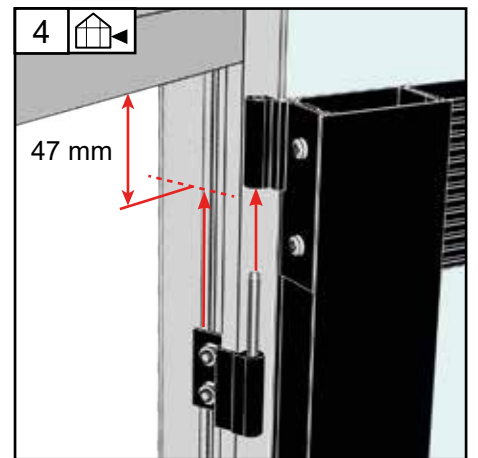
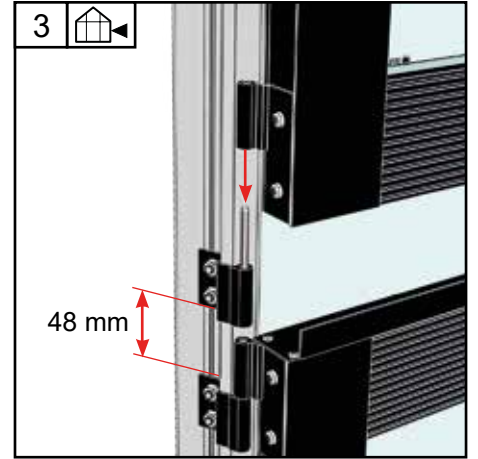
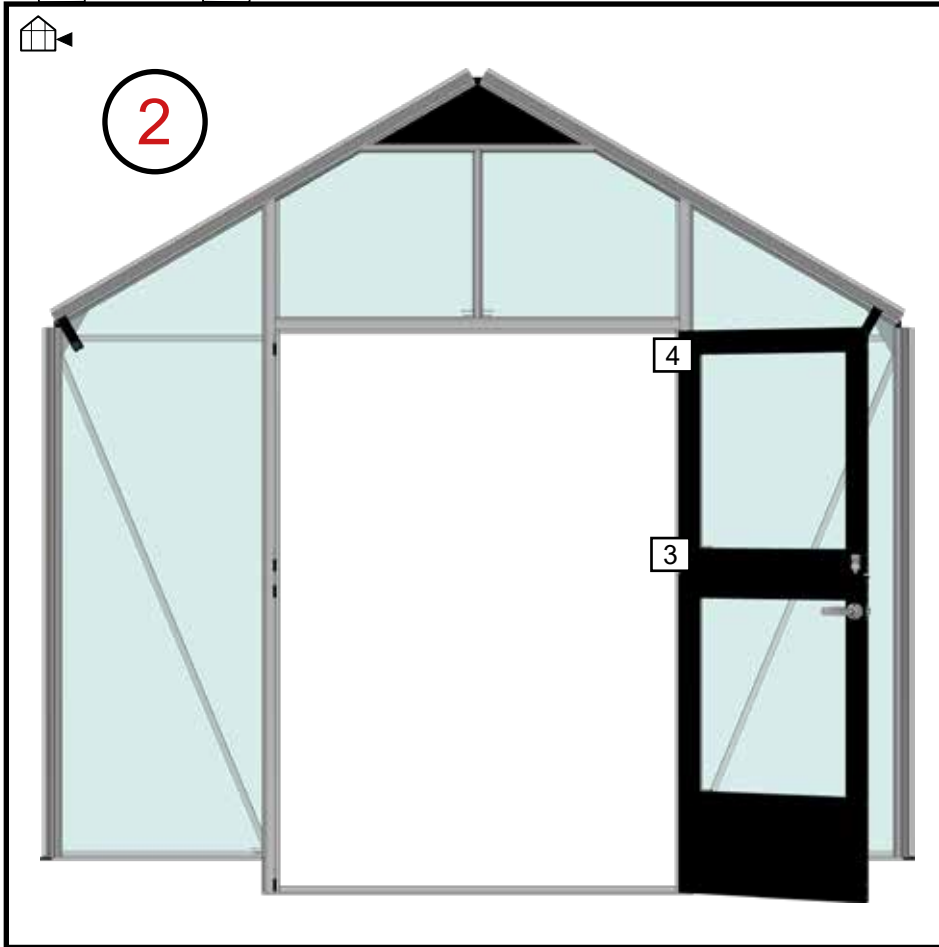

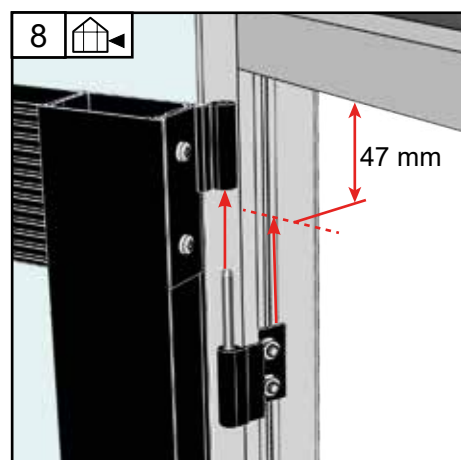
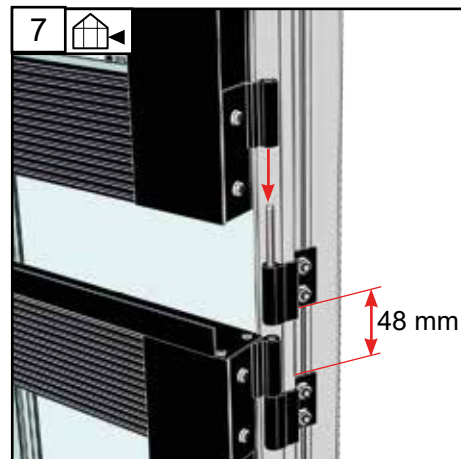
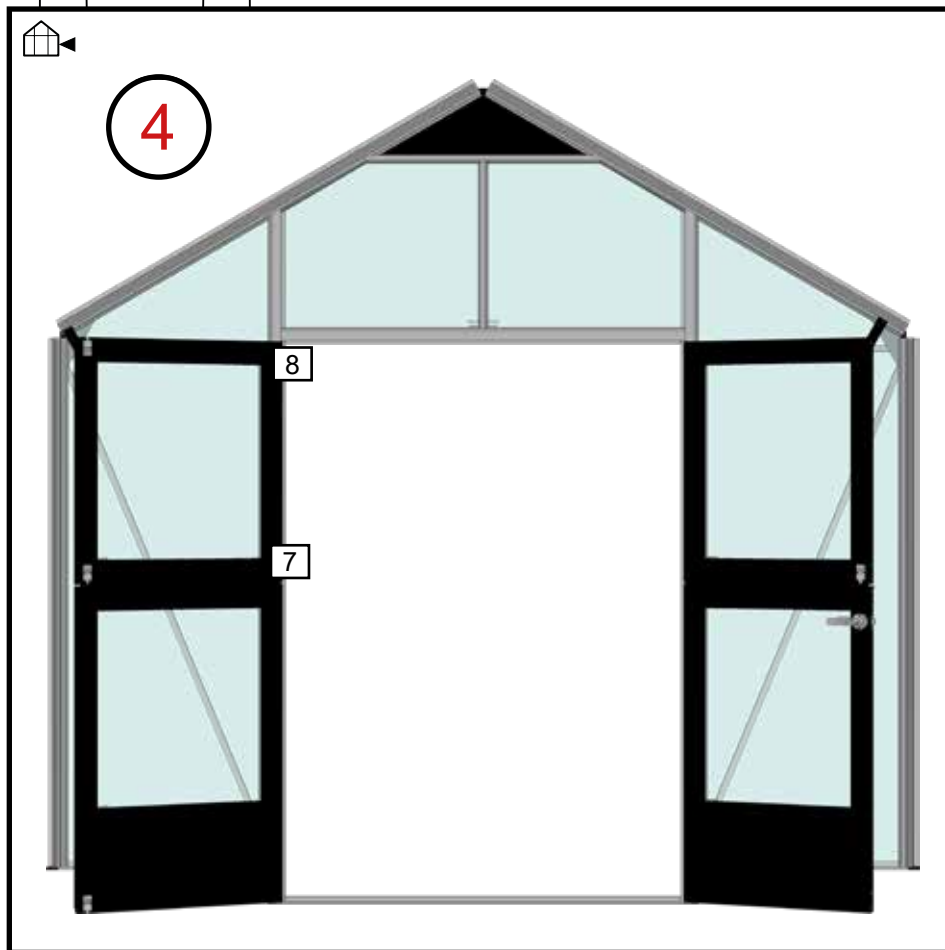

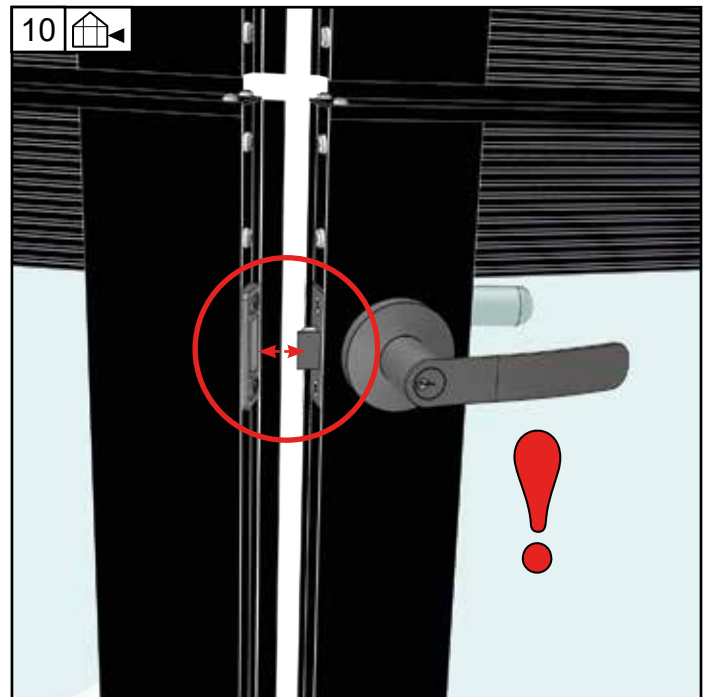
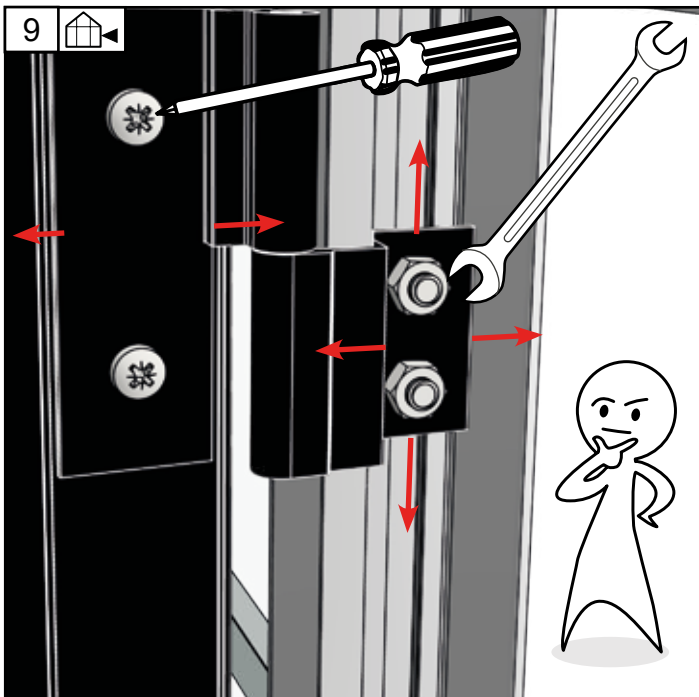
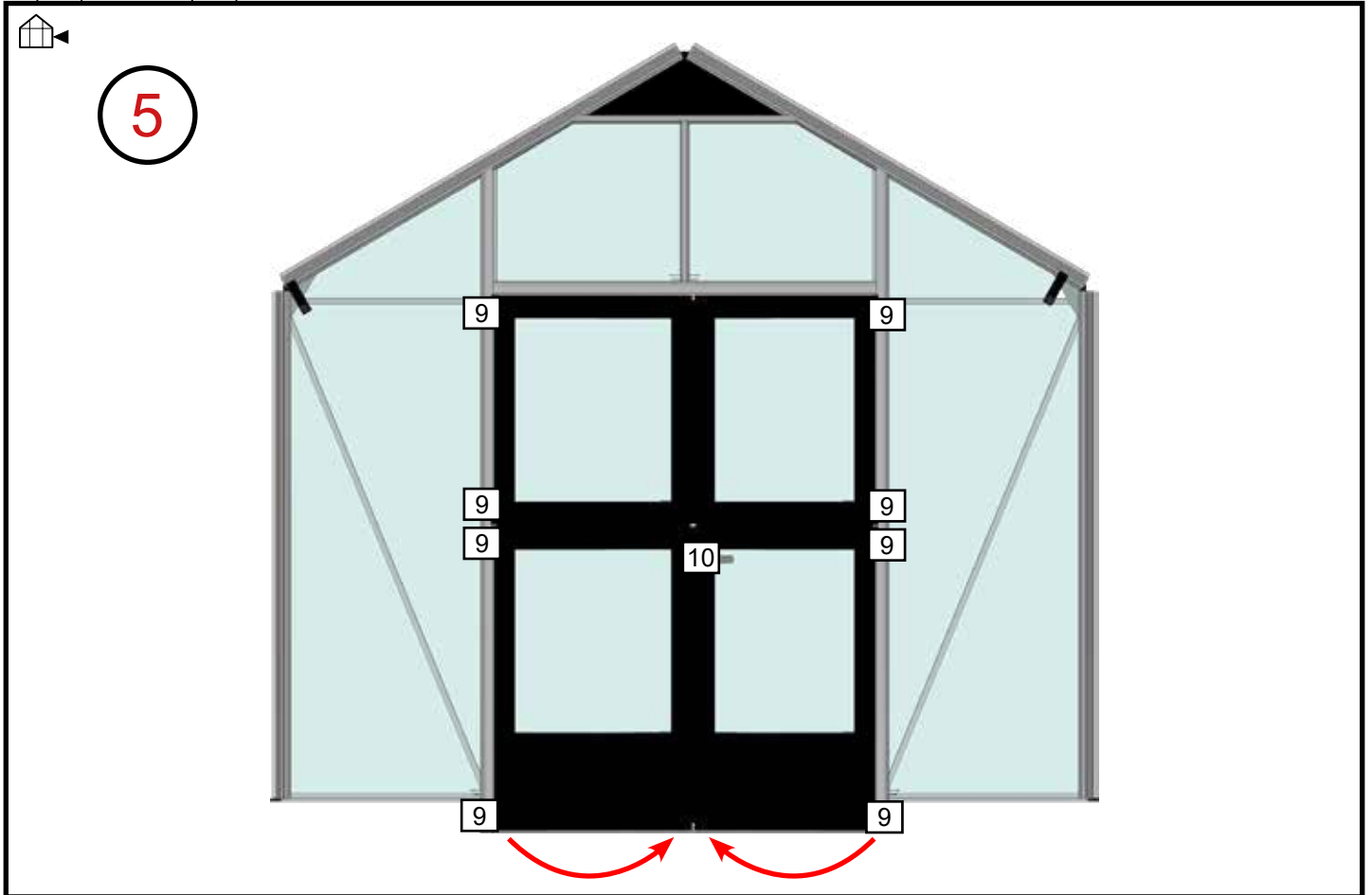

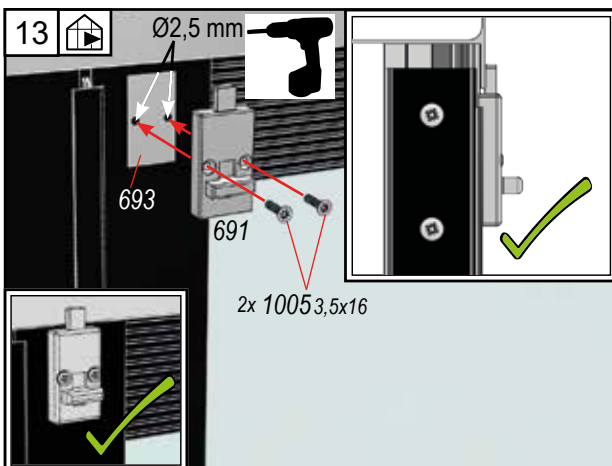
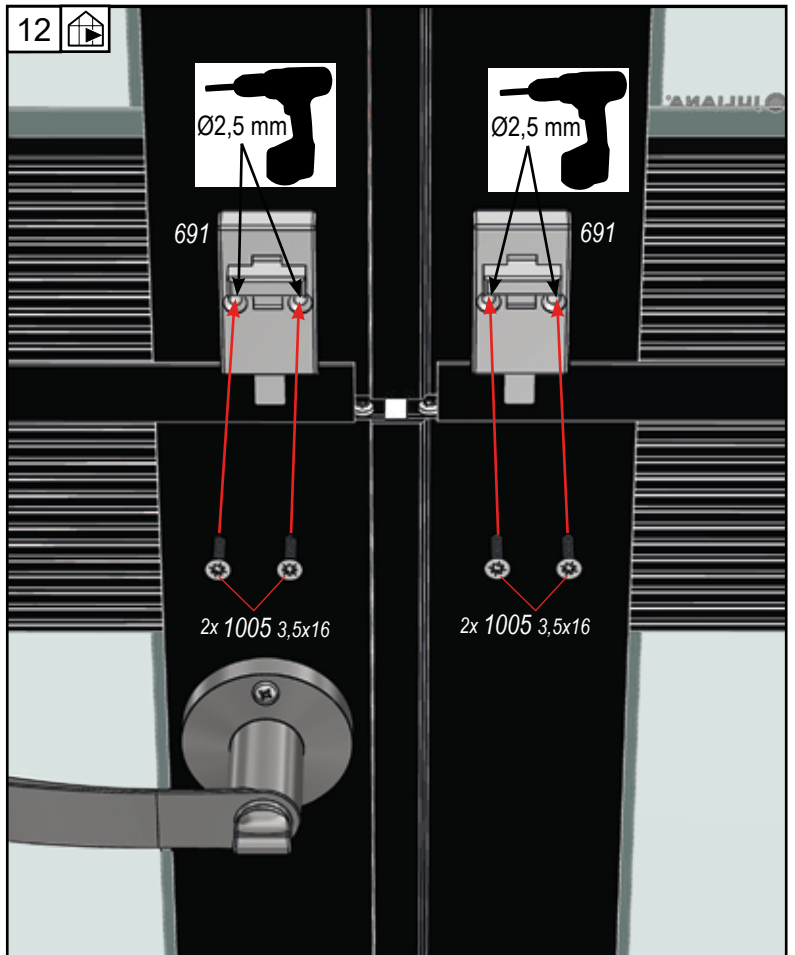
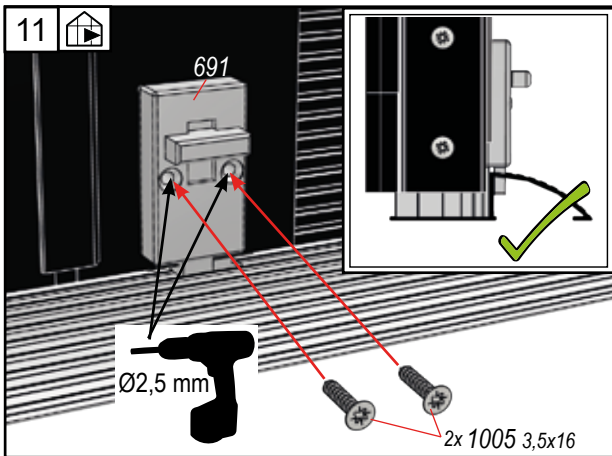
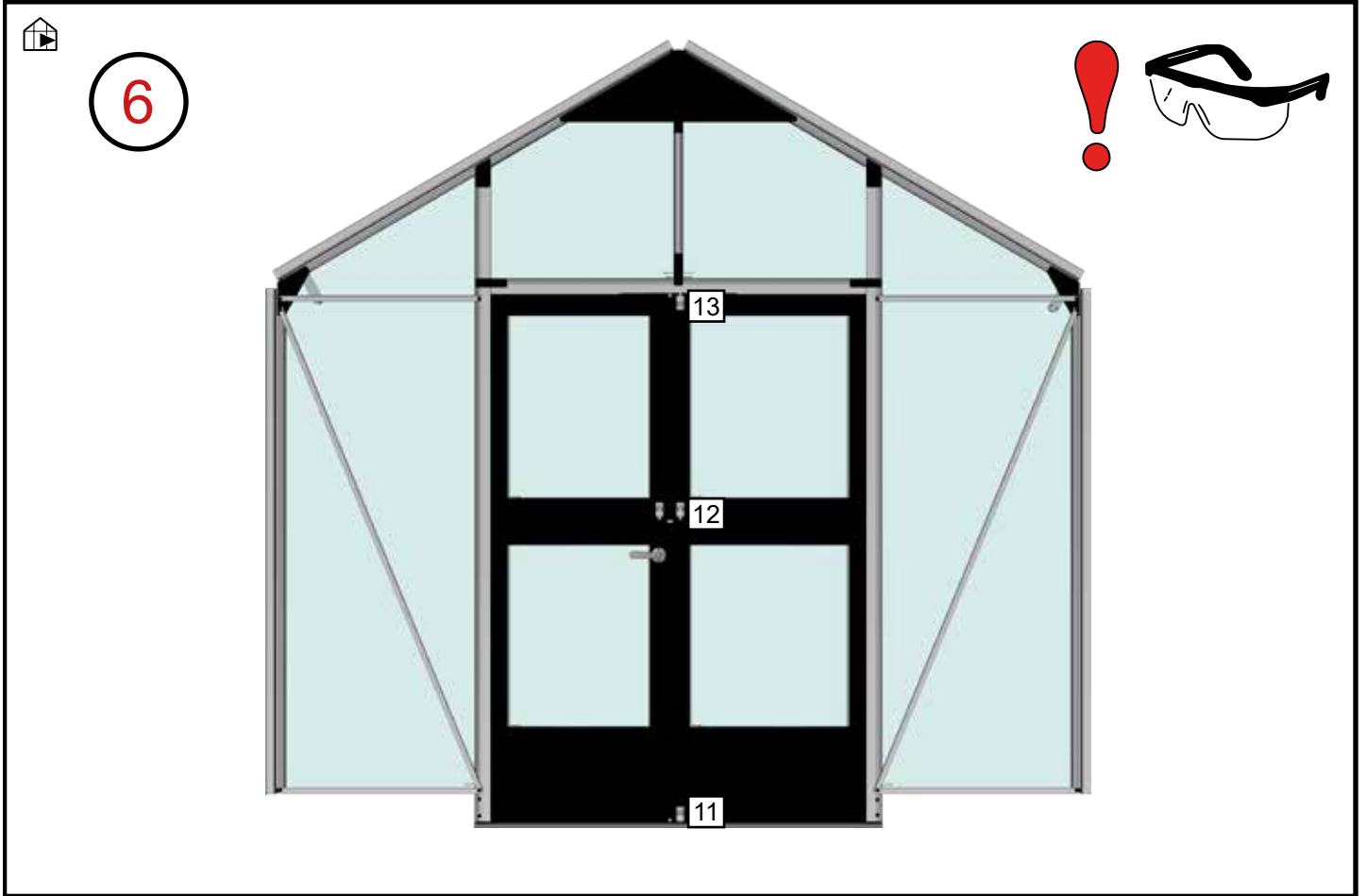
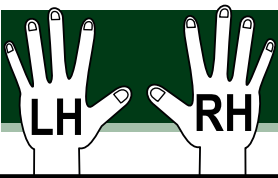

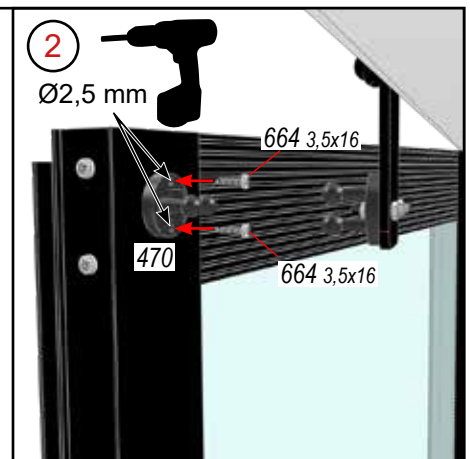
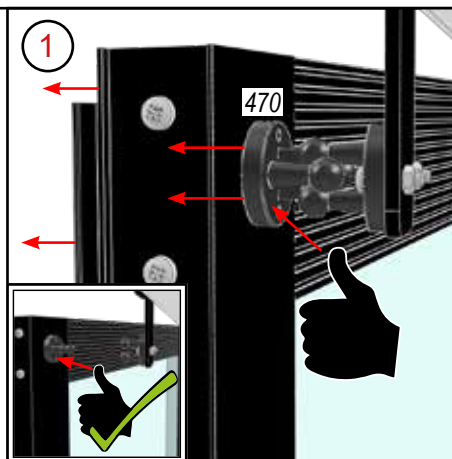
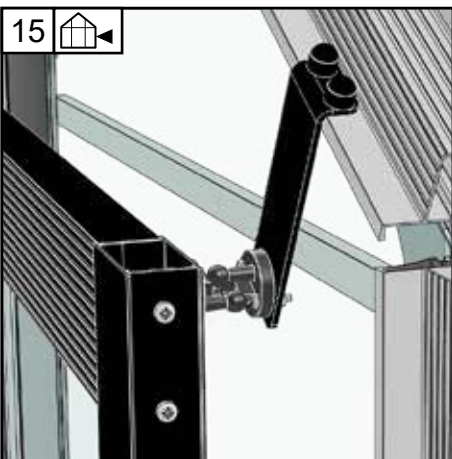
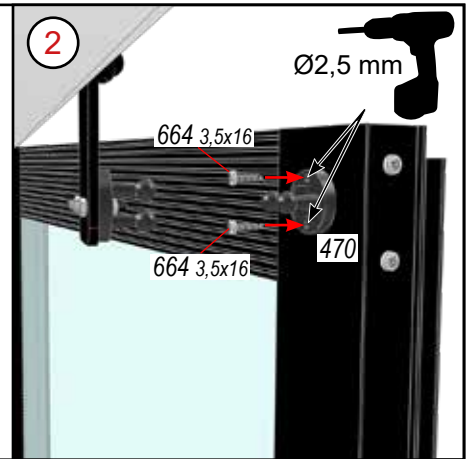
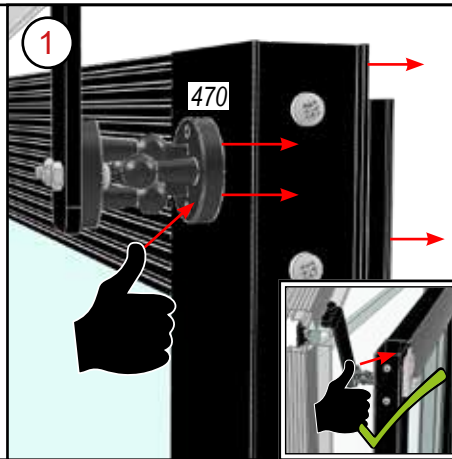
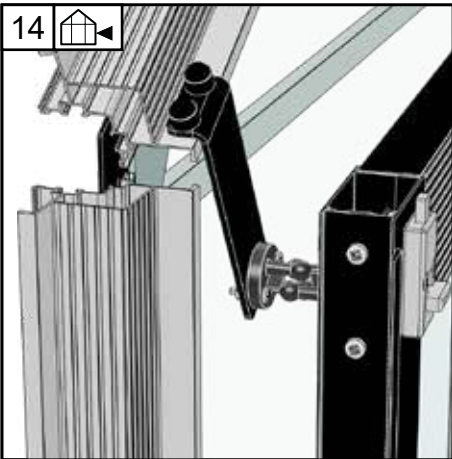
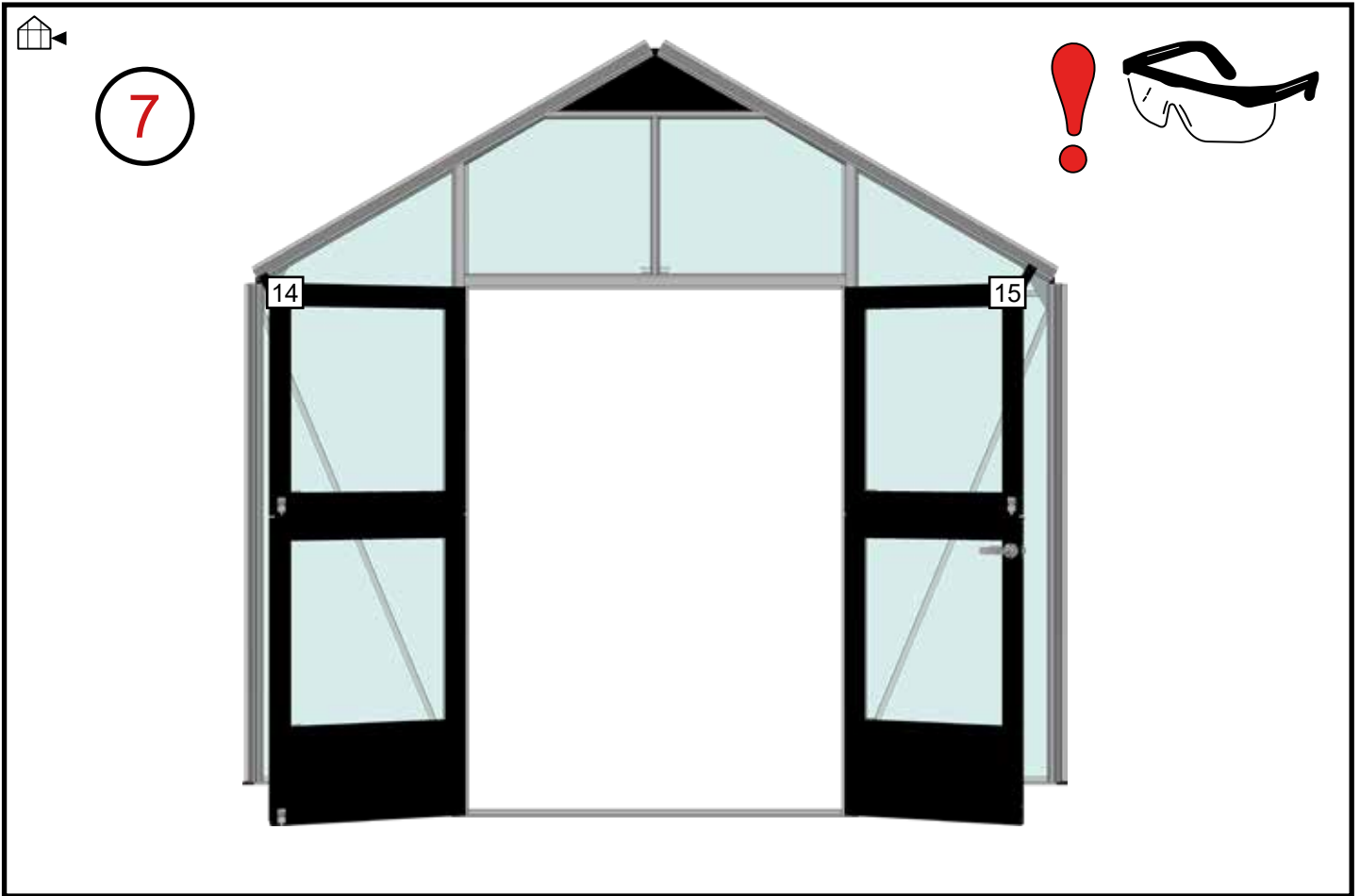
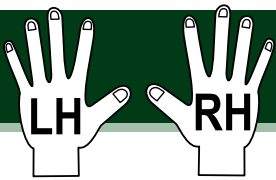

Vinduer - Windows - Fenster - Fönster - Fenêtres -
Ramen - Ikkunoita - Okno



Afslutning - Finishing - Fertigstellung - Slutför - Aperçu -
Afwerking - Viimeistely - Wykończenie

