

# Ekstra dørsæt Extra door kit Extra Tür-Set

Extra dörrar set - Kit de porte supplémentaire - Extra doos deuronderdelen  
Ylimääräinen ovisarja - Dodatkowy zestaw drzwi

4 Sections

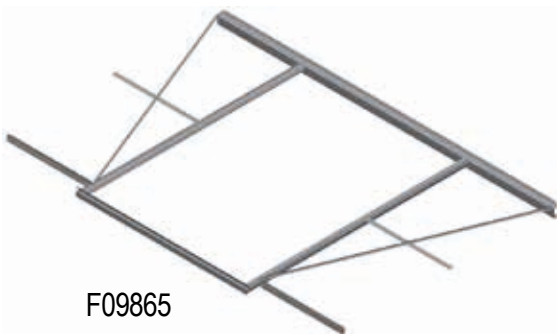

F09865

5 Sections

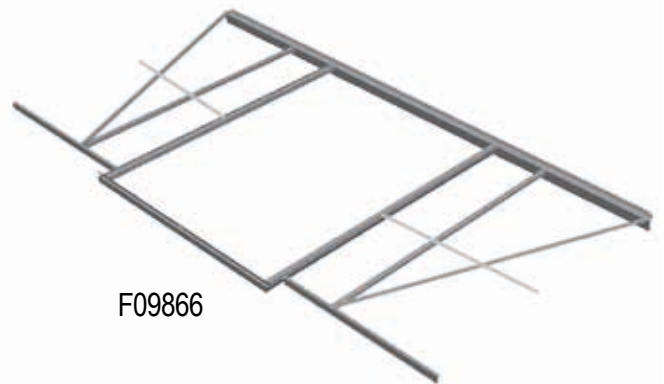

F09866

6 Sections

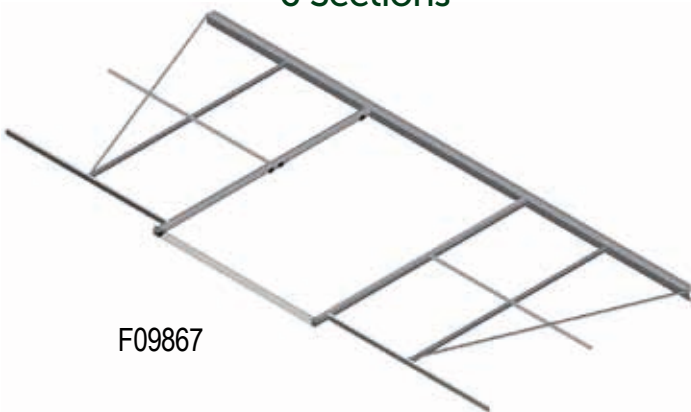

F09867

7 Sections



F09868

24022022 - 2.00

Montagevejledning · Assembly Instructions · Montageanleitung  
Monteringsanvisning · Instructions de montage · Montagehandleiding  
Kokoamisohje · Instukcja montażu

# TILBEHØR · ACCESSORIES · ZUBEHÖR · ACCESSOIRES



Juliana tagudsmykning  
Juliana roof decoration  
Juliana Dachdekoration  
Crête de faitage Juliana



Juliana Univent automatisk vinduesåbner  
Juliana Univent automatic window opener  
Juliana Univent automatischer Fensteröffner  
Ouverture automatique fenêtre Juliana Univent



Juliana integreret drivhusbord sort  
Juliana integrated table black  
Juliana integrierte Regale Schwarz  
Table intégrée noire Juliana



Juliana integreret drivhushylde sort  
Juliana integrated shelve black  
Juliana integriert Regale Schwarz  
Étagère intégrée noire Juliana



Juliana regnvandsopsamler  
Juliana rainwater butt  
Juliana Wasserspeicher  
Récupérateur eau de pluie Juliana



Juliana kapilærkasseskjuler  
Juliana capillary planter collector  
Juliana Pflanzgefäß  
Jardinière pour auto-arrosage Juliana

# Oversigt - Overview - Übersicht - Översikt - Détails Overzicht - Sisällys - Zawartość







4 Sections F09865			5 Sections F09866			6 Sections F09867			7 Sections F09868		
#	F29200	4 Sec.	#	F29201	5 Sec.	#	F29202	6 Sec.	#	F29203	7 Sec.
Profiler - Profiles - Profile			Profiler - Profiles - Profile			Profiler - Profiles - Profile			Profiler - Profiles - Profile		
741	00510741S	2	1100	00511100S	2	1459	00511459S	2	1818	00511818S	2
1468	00511468S	1	1468	00511468S	1	1468	00511468S	1	1468	00511468S	1
341S	00310341S	1	341S	00310341S	1	341S	00310341S	1	341S	00310341S	1
342S	00310342S	1	342S	00310342S	1	342S	00310342S	1	342S	00310342S	1
00	13-20301468-00S	1	00	13-20301468-00S	1	00	13-20301468-00S	1	00	13-20301468-00S	1
11	13-20151920-11A	2	11	13-20151920-11A	2	11	13-20151920-11A	2	11	13-20151920-11A	2
09	13-10020742-09A	1	09	13-10021101-09A	1	09	13-10021460-09A	1	09	13-10021819-09A	1
10	13-10020742-10A	1	10	13-10021101-10A	1	10	13-10021460-10A	1	10	13-10021819-10A	1
90	13-10680742-90A	2	90	13-10681100-90A	2	90	13-10681460-90A	2	90	13-10681819-90A	2

3 mm - Hærdet glas - Toughened glass - Sicherheitsglas		
#	F11200	4 Sec. 6 Sec.
G	00281507	2
H	00281508	2
#	F11201	5 Sec. 7 Sec.
G	00281507	2
H	00281508	2
A1	00281534	2

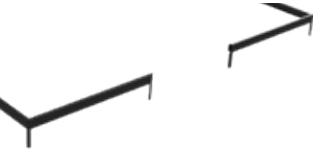
Dør - Door - Tür		
#	Box 8	4 Sec. 5 Sec. 6 Sec. 7 Sec.
55	13-20170517-55S	4
56	13-20160517-56S	1
57	13-20221075-57S	1
58	13-20221075-58S	1
59	13-20220812-59S	2
61	13-10020651-61S	1
340S	00310340S	1

Dør - Door - Tür		
#	Box 9	4 Sec. 5 Sec. 6 Sec. 7 Sec.
59	13-20220812	1
62	13-20170578-62S	4
63	13-20160578-63S	1
64	13-20231075-64S	1
65	13-20221075-65S	1
66	13-20230812-66S	1
67	13-10020712-67S	1
339S	00310339S	1

Oversigt - Overview - Übersicht - Översikt - Détails  
 Overzicht - Sisällys - Zawartość

	
	5
4 Sections 	6
5 Sections 	7
6 Sections 	8
7 Sections 	9
	10
	11 - 13

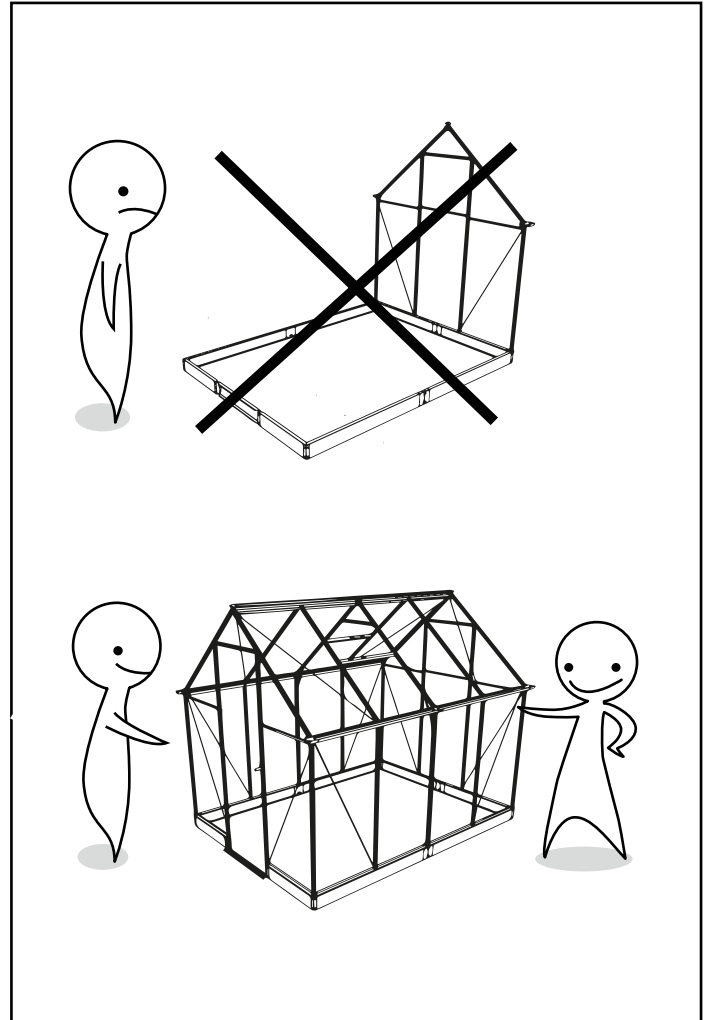

Anbefalet Værktøj - Recommended Tools -  
 Empfohlen Werkzeug - Rekomenderas Verktyg -  
 Recommandés Outils - Aanbevolen Gereedschap -  
 Suositellut Työkalut - Zalecane Narzędzia



# Fundament - Base - Embase - Fundering - Perustus

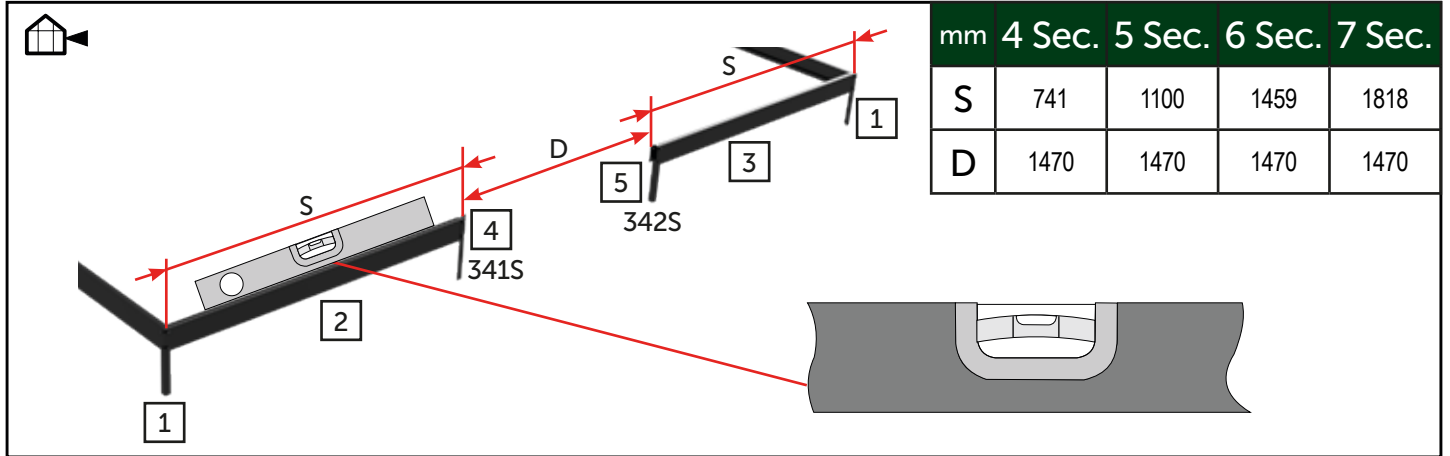

	#	mm	
	741	741	2 (4 Sec.)
	1100	1100	2 (5 Sec.)
	1459	1459	2 (6 Sec.)
	1818	1818	2 (7 Sec.)
	1468	1468	1
	341S	345	1
	342S	345	1
	995	M6x10	12
	996	M6	12
	280	M6	8

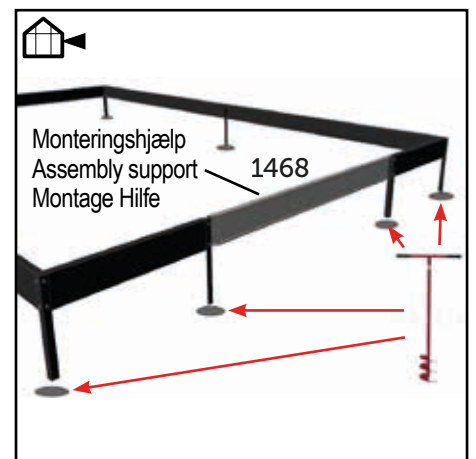
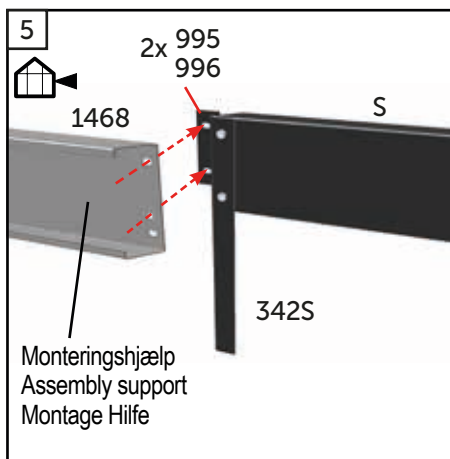
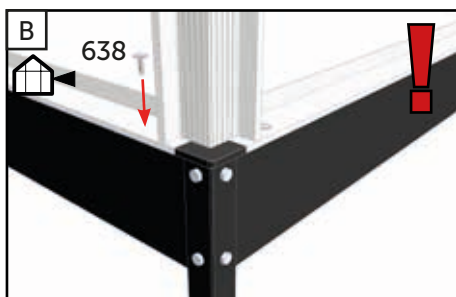
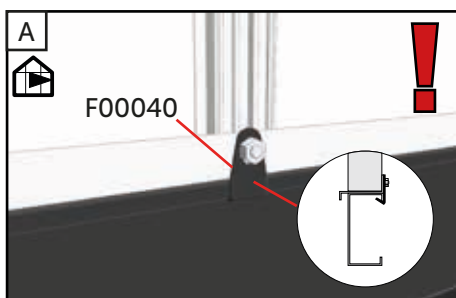
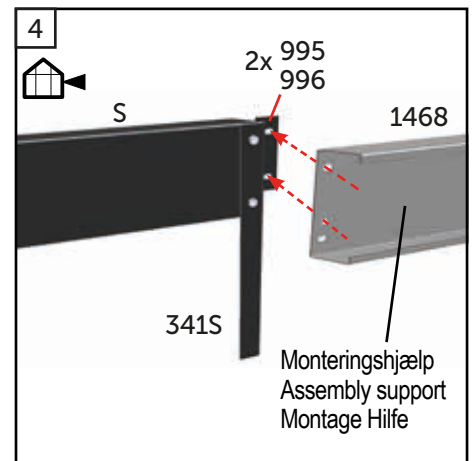
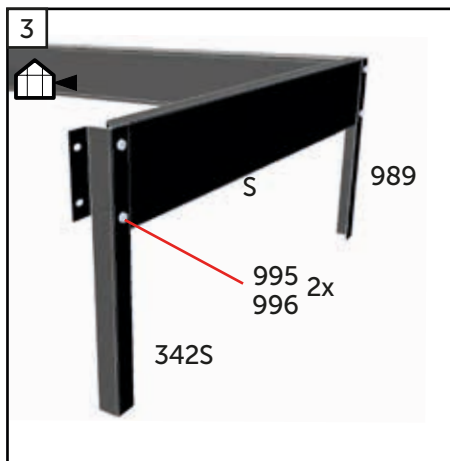
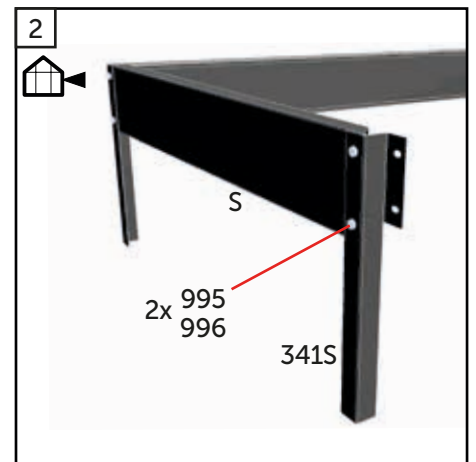
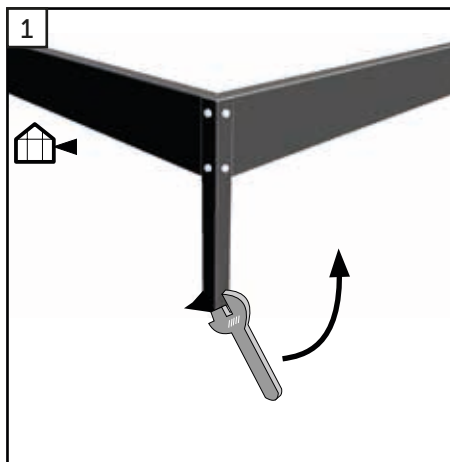

# 4 Sec.

For - Front - Vorder - Front - Devant - Voor - Ovi - Przednia

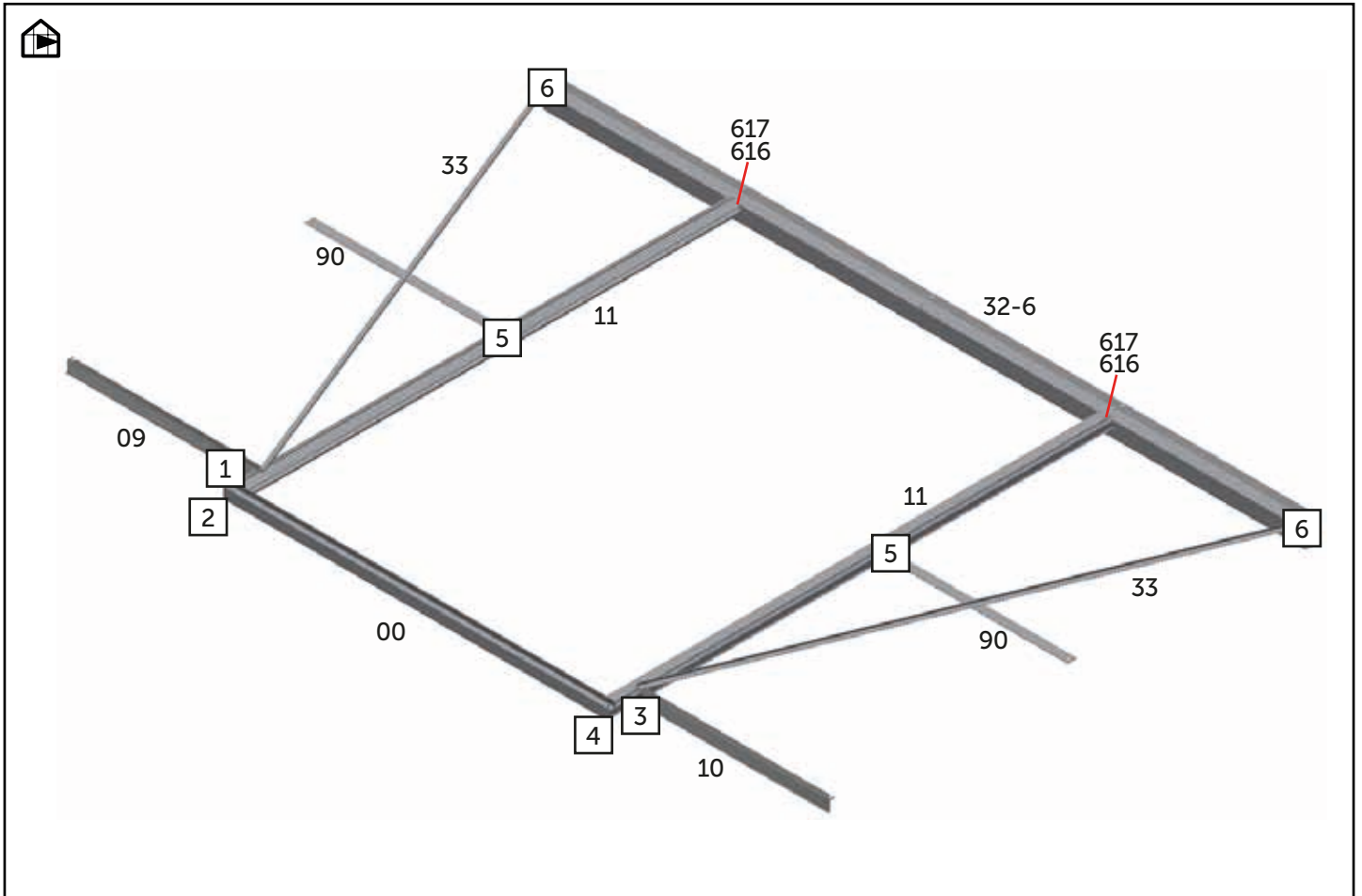

	#	mm	4 Sec.
	00	1468	1
	09	742	1
	10	742	1
	11	1920	2
	90	742	2
Fittings			
	05	-	4
	06	-	4
	616	M6	34
	617	M6x11	34
	280	M6	34

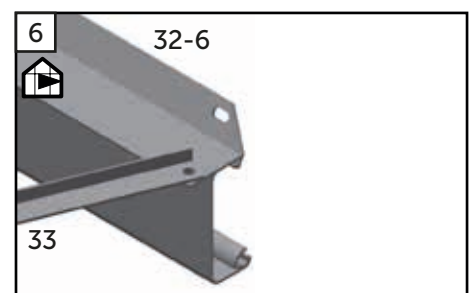
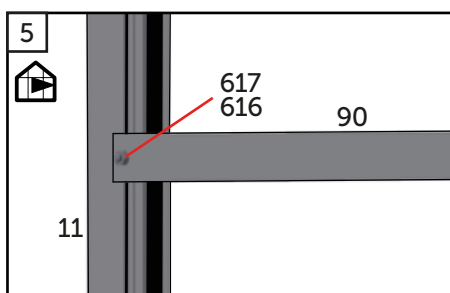
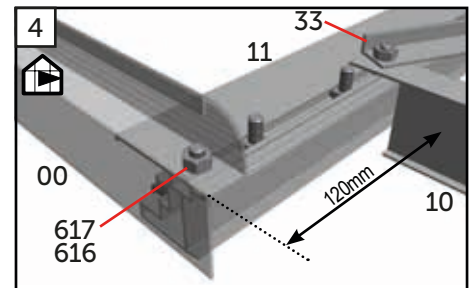
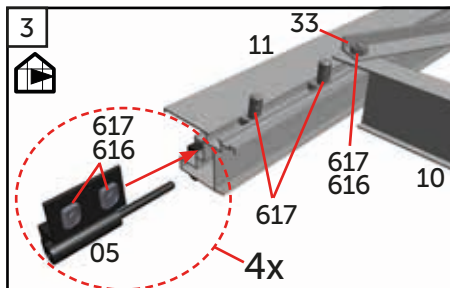
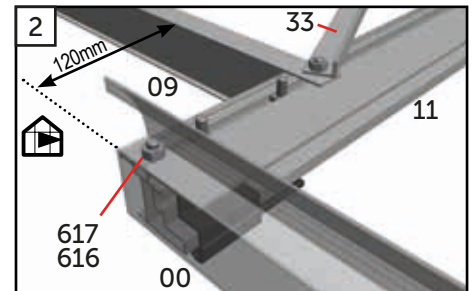
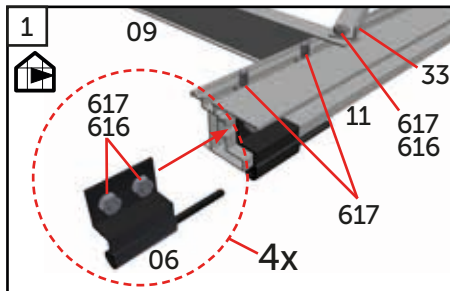

# 5 Sec.

For - Front - Vorder - Front - Devant - Voor - Ovi - Przednia

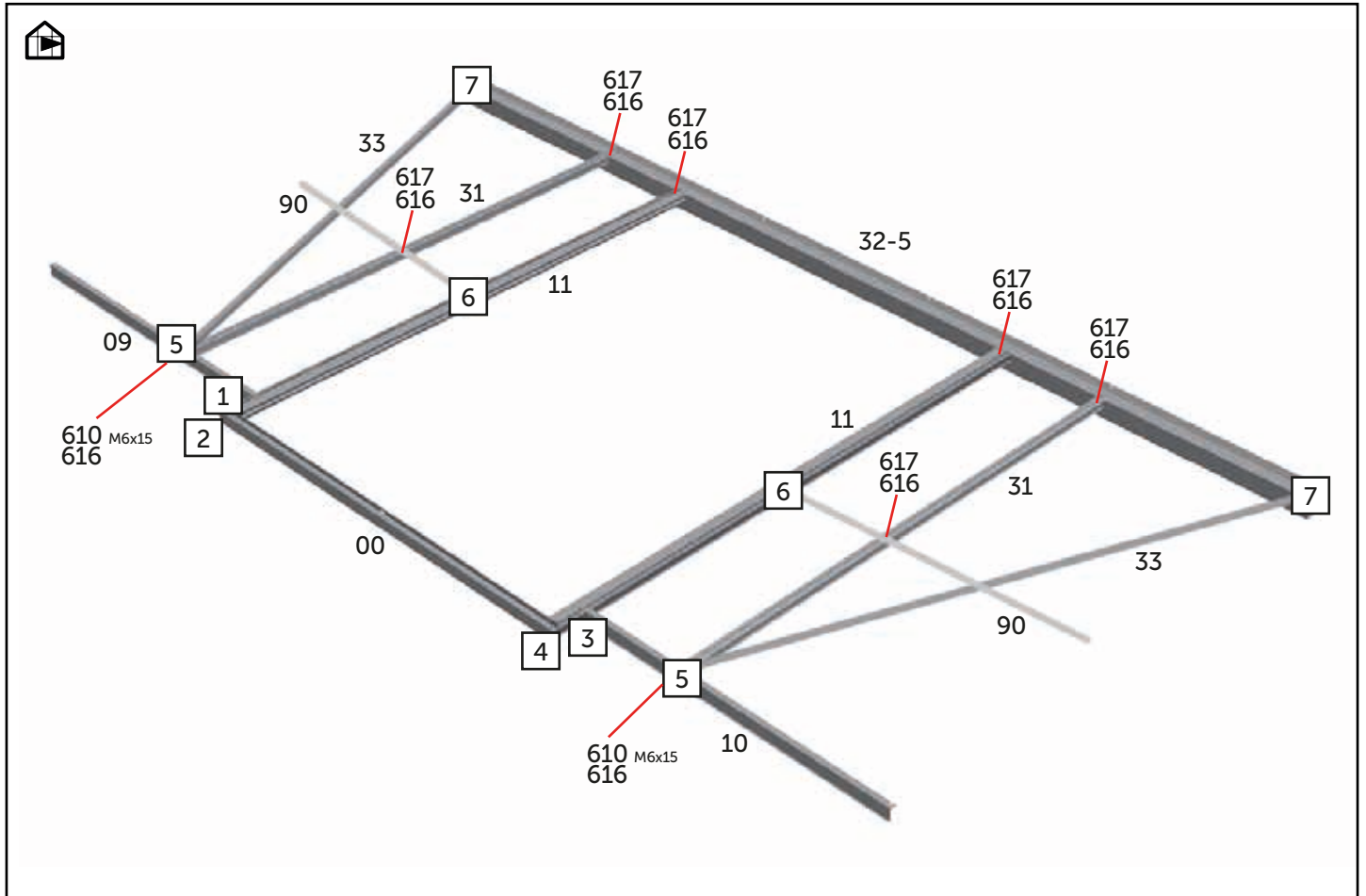

	#	mm	5 Sec.
	00	1468	1
	09	1101	1
	10	1101	1
	11	1920	2
	90	1100	2
Fittings			
	05	-	4
	06	-	4
	610	M6x15	2
	616	M6	40
	617	M6x11	38
	280	M6	40

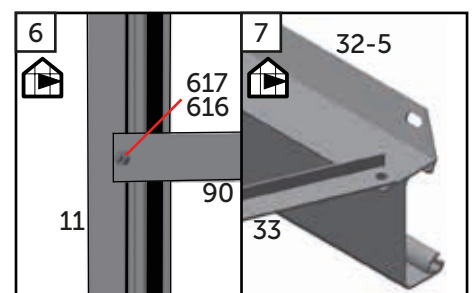
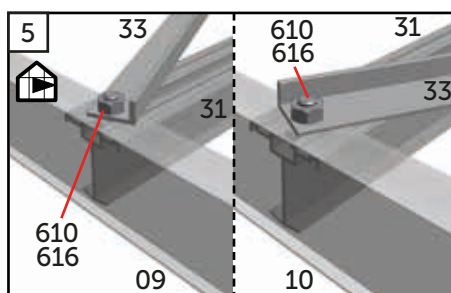
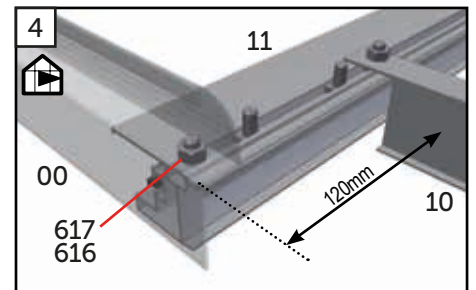
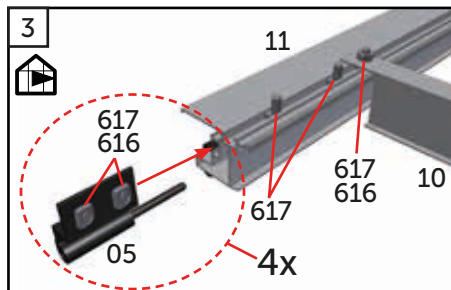
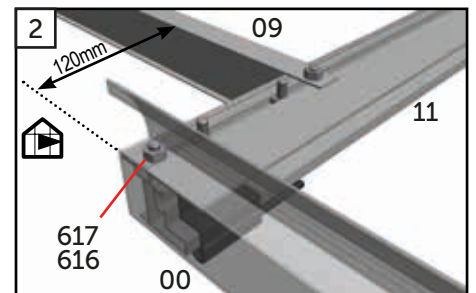
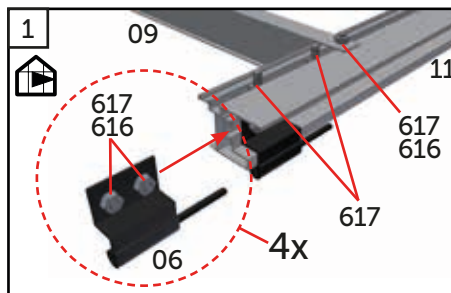

# 6 Sec.

For - Front - Vorder - Front - Devant - Voor - Ovi - Przednia

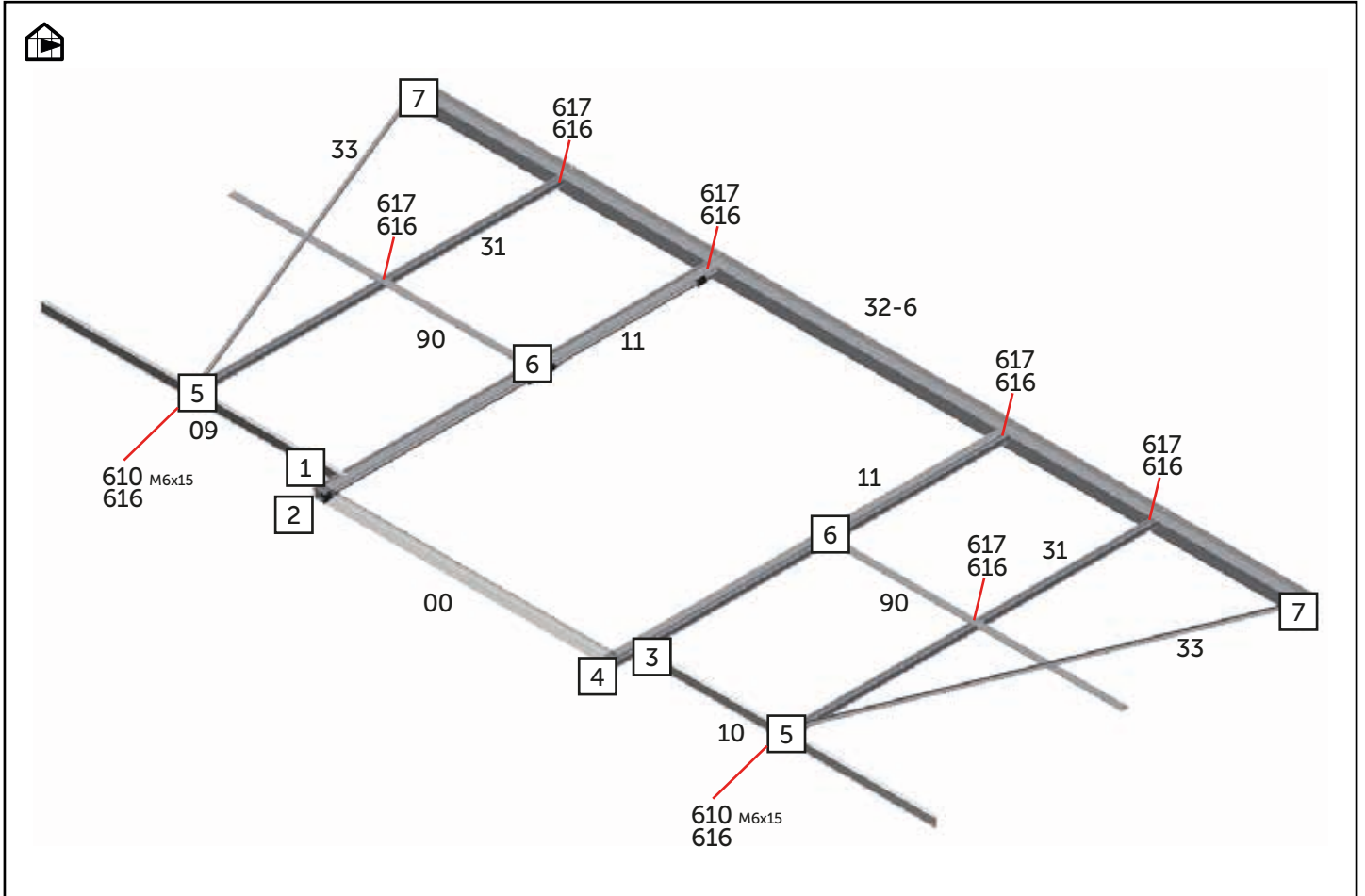

	#	mm	6 Sec.
	00	1468	1
	09	1460	1
	10	1460	1
	11	1920	2
	90	1460	2
<b>Fittings</b>			
	05	-	4
	06	-	4
	610	M6x15	2
	616	M6	40
	617	M6x11	38
	280	M6	40

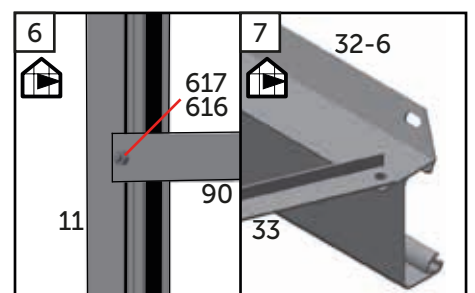
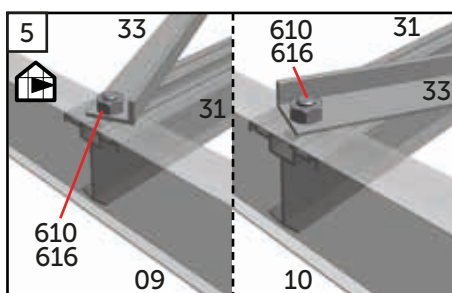
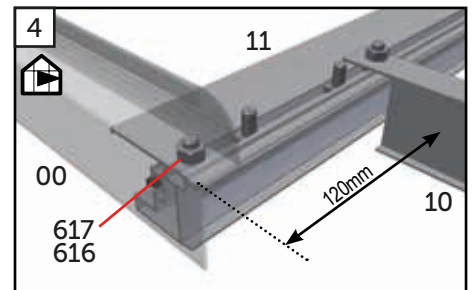
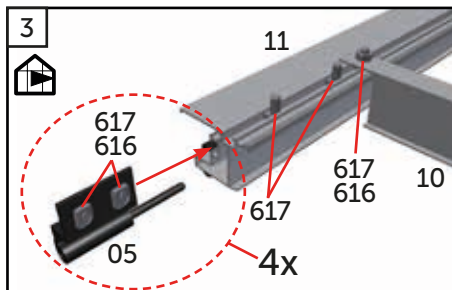
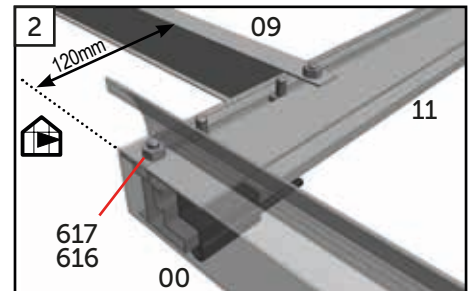
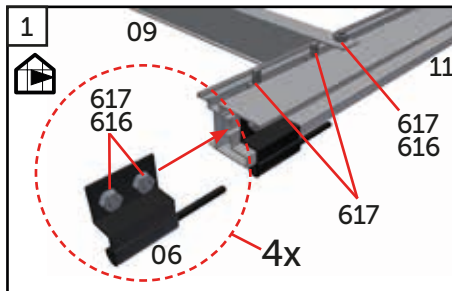

# 7 Sec.

For - Front - Vorder - Front - Devant - Voor - Ovi - Przednia

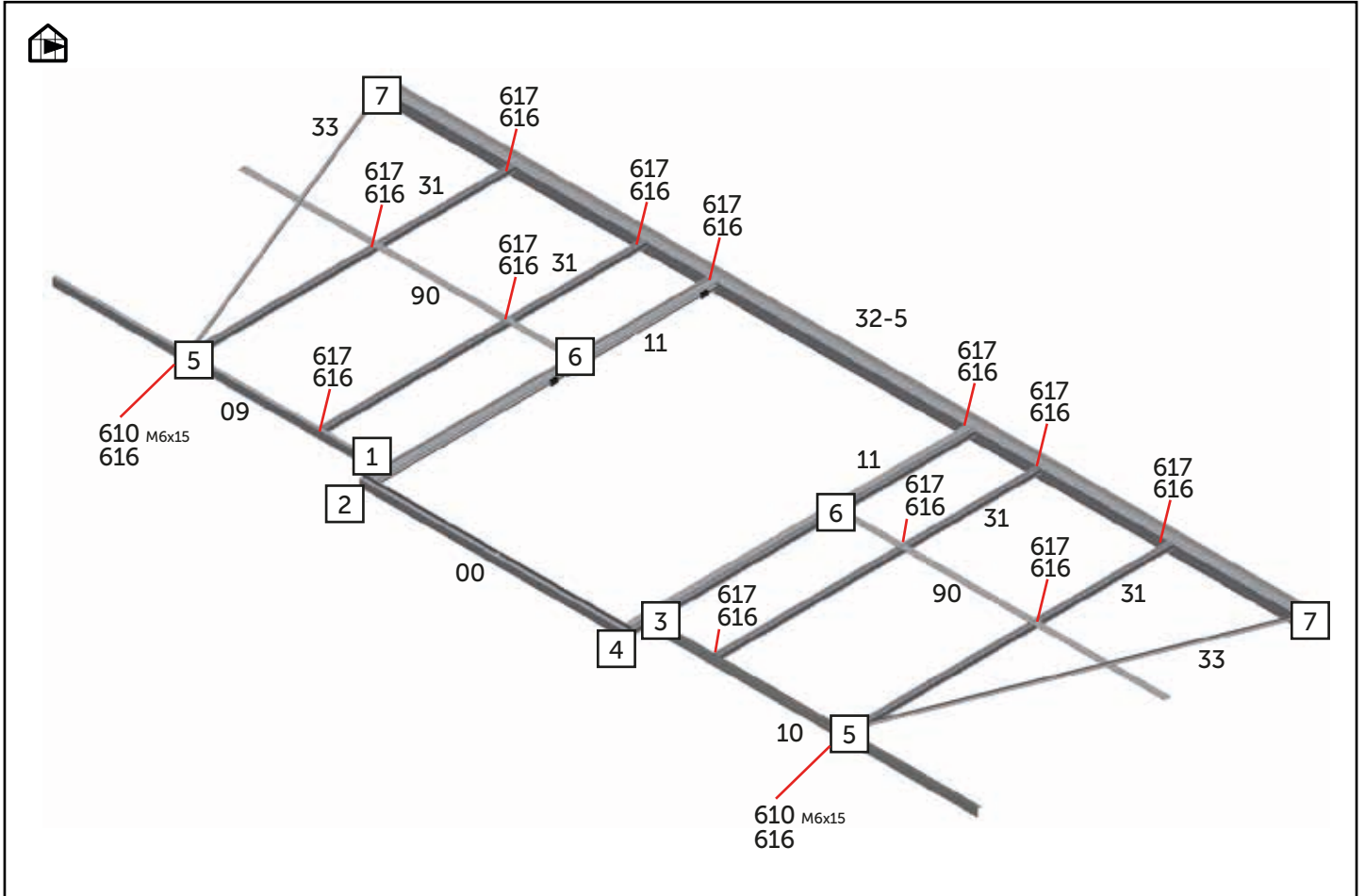

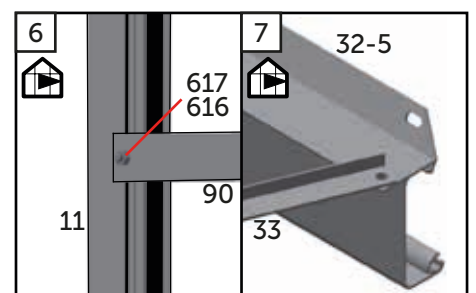
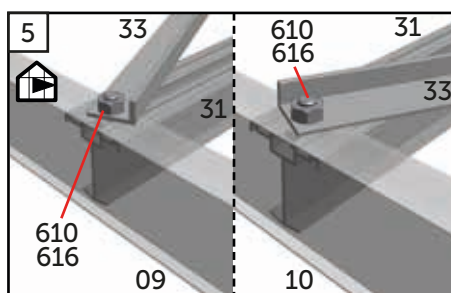
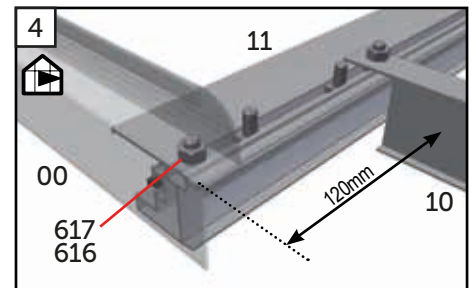
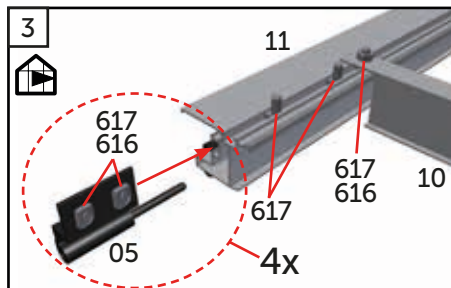
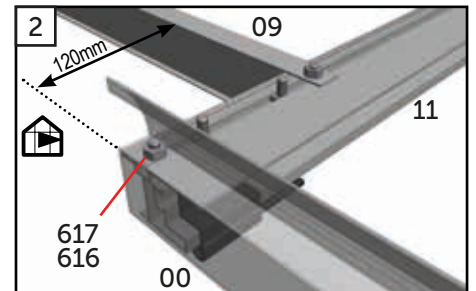
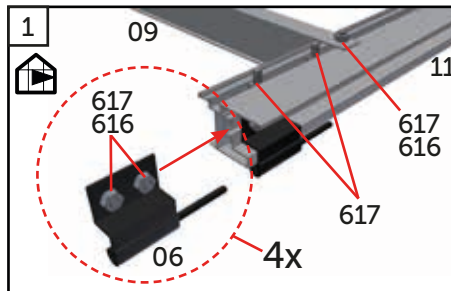

	#	mm	7 Sec.
	00	1468	1
	09	1819	1
	10	1819	1
	11	1920	2
	90	1819	2
<b>Fittings</b>			
	05	-	4
	06	-	4
	610	M6x15	2
	616	M6	46
	617	M6x11	44
	280	M6	46

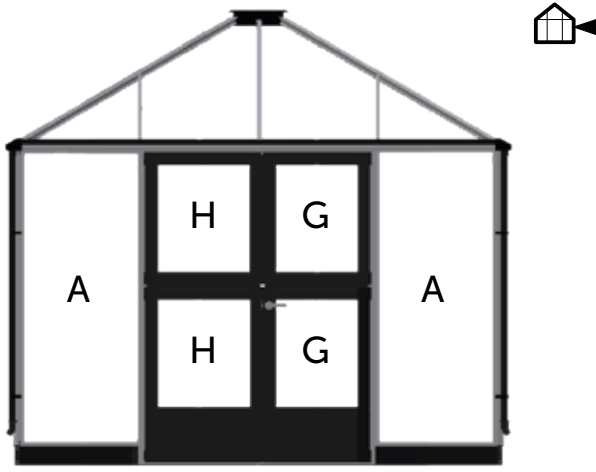

4 Sections



	#	mm	4.	5.	6.	7.
	A1	341x1797	-	2	-	2
	G	517x700	2	2	2	2
	H	578x700	2	2	2	2

5 Sections

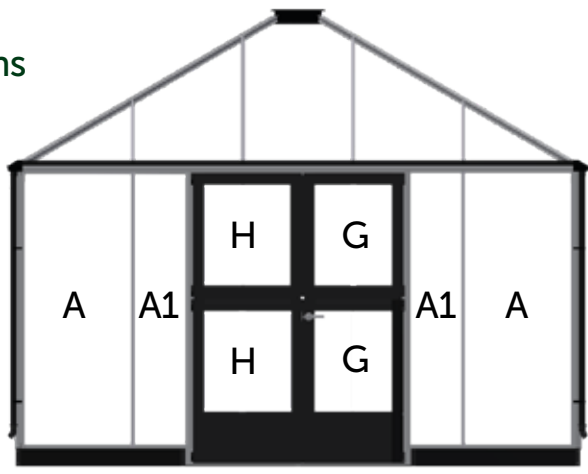

6 Sections

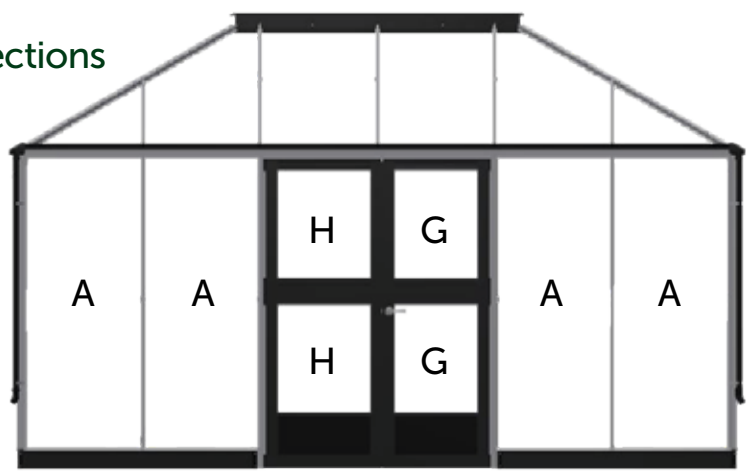

7 Sections

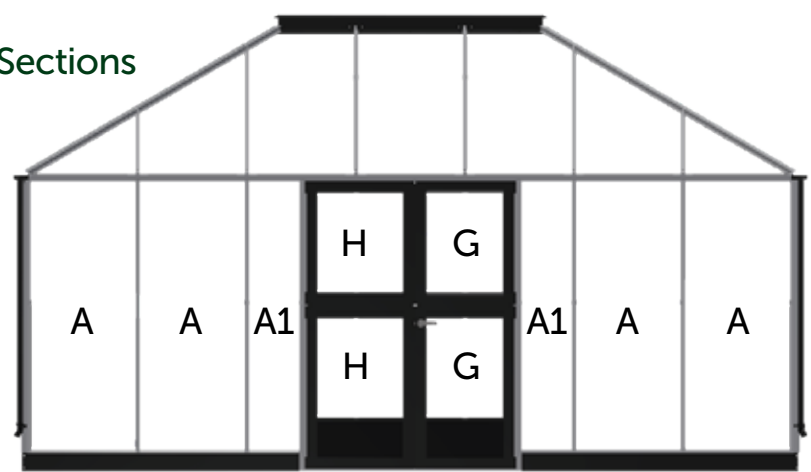

# Dør - Door - Tür - Dörr - Porte - Deur - Ovi - Drzwi

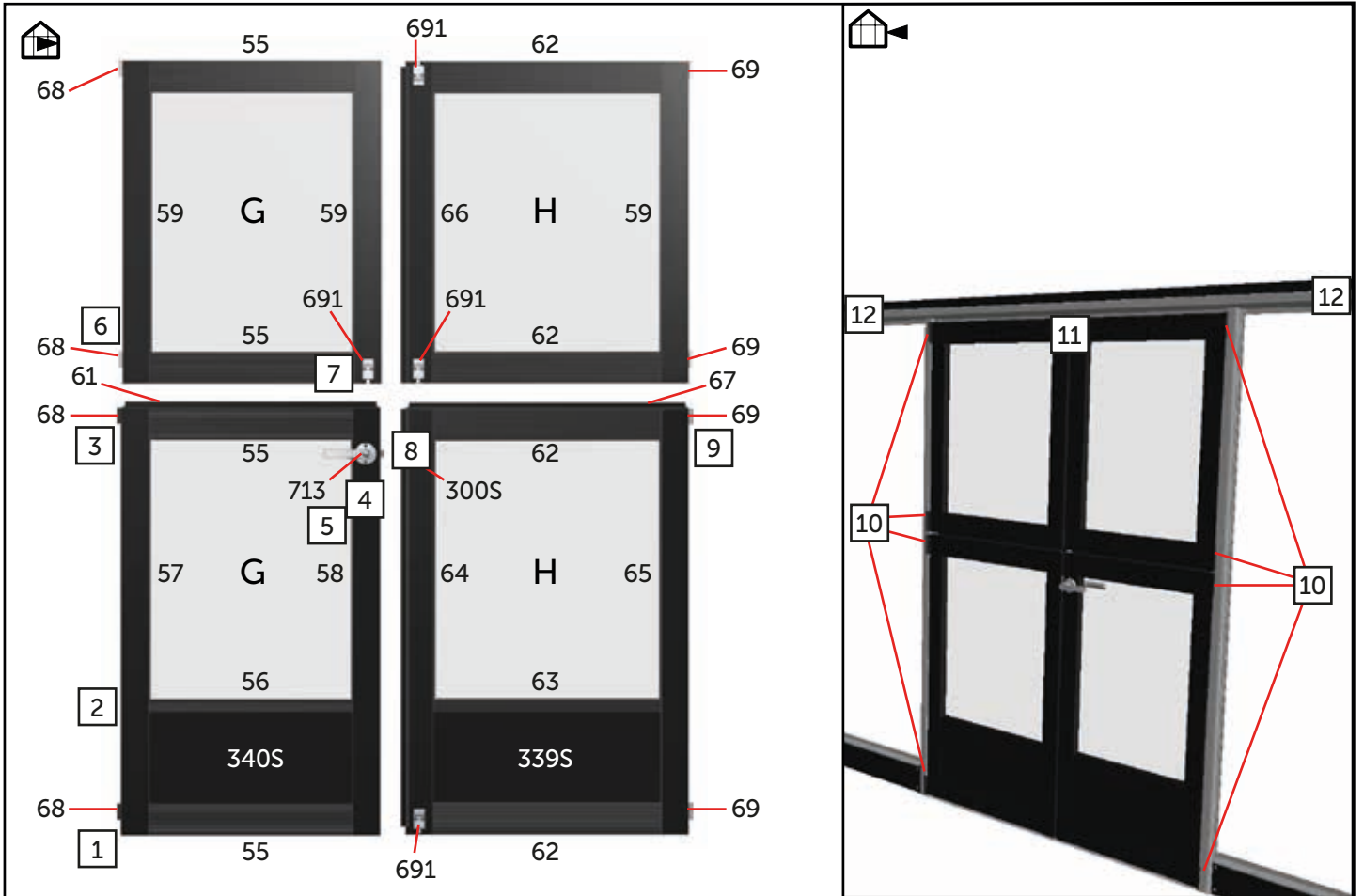

Box 8	#	mm	Qty
	55	517	4
	56	517	1
	57	1075	1
	58	1075	1
	59	812	2
	61	651	1
	340S	261x517	1

Box 9	#	mm	Qty
	59	812	1
	62	578	4
	63	578	1
	64	1075	1
	65	1075	1
	66	812	1
	67	712	1
	339S	261x578	1

#	mm	Qty	
Fittings			
	68	-	4
	69	-	4
	300S	-	1
	351	-	2
	470	-	4
	616	M6	4
	617	M6x11	4
	662	5x80	36
	664	3,5x16	12
	668	M4x16	4
	669	M4	4
	691	-	4
	713	-	1
	1005	3,5x16	8
	1011	4,2x13	2
	280	M6	4

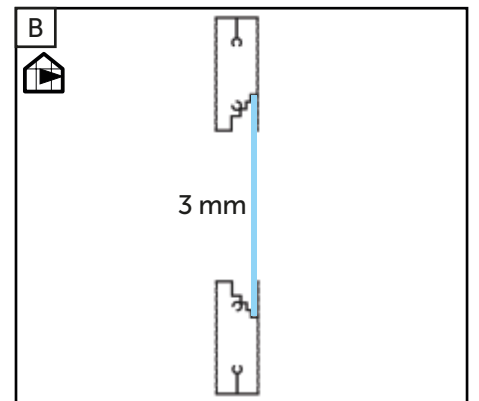
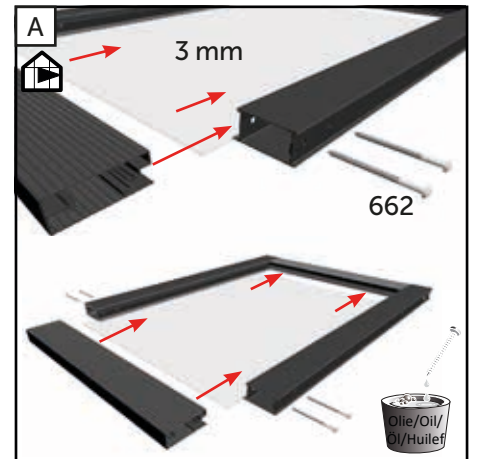

# Dør - Door - Tür - Dörr - Porte - Deur - Ovi - Drzwi

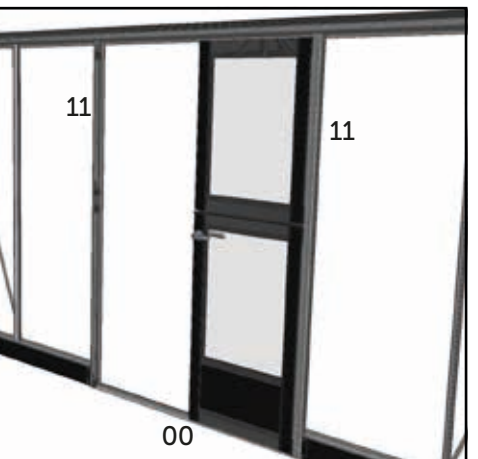
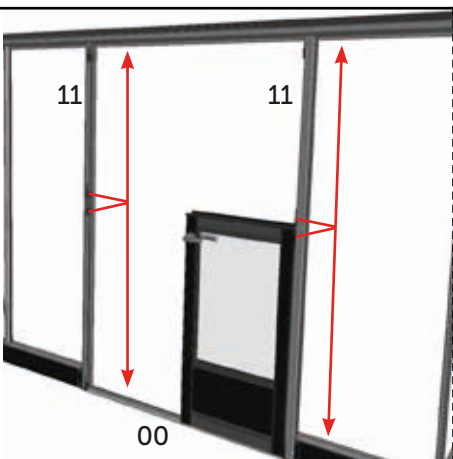
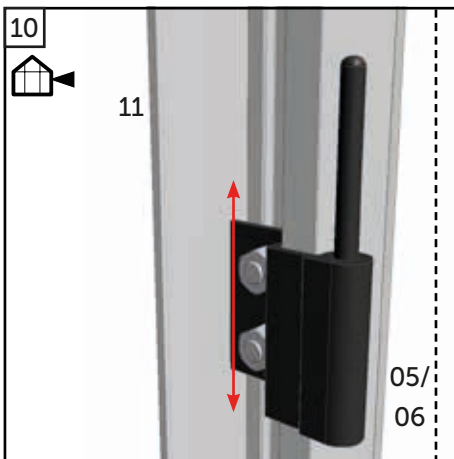
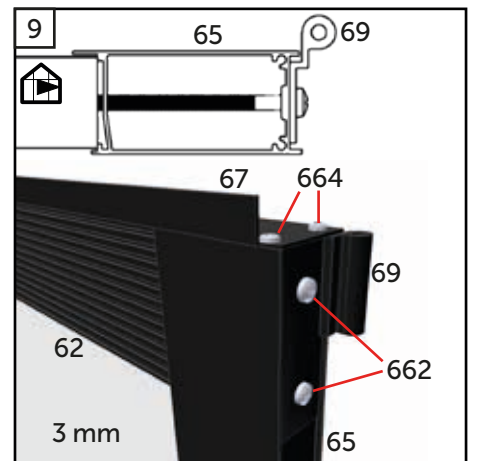
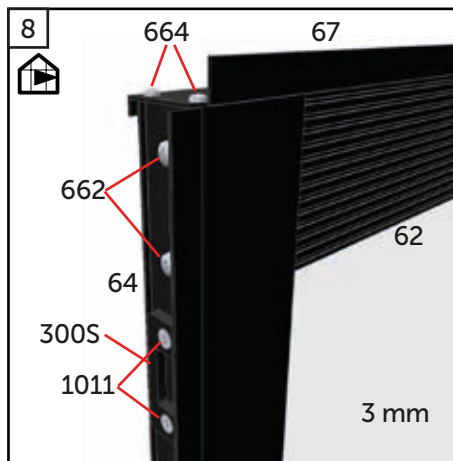
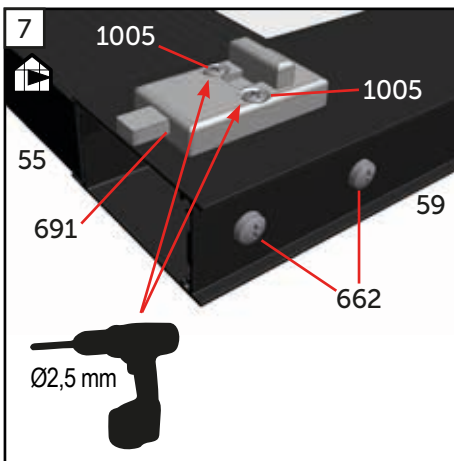
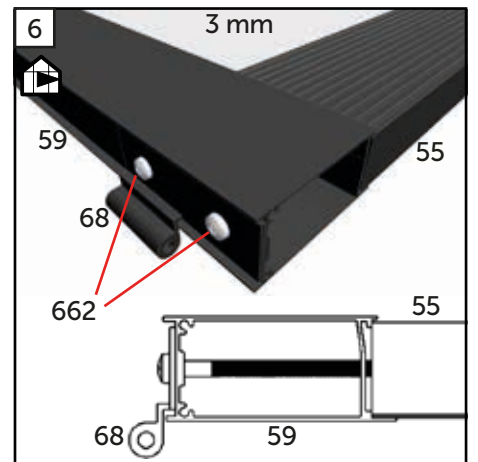
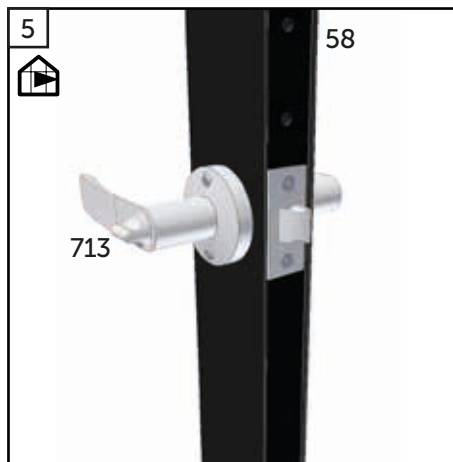
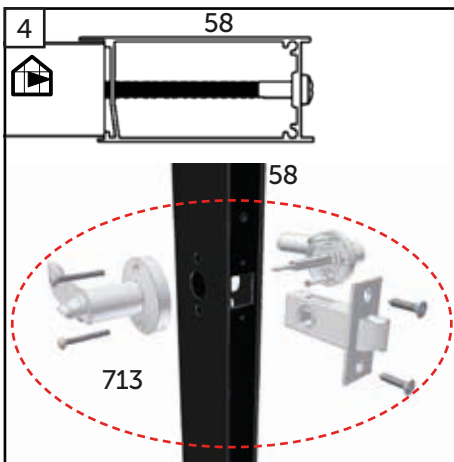
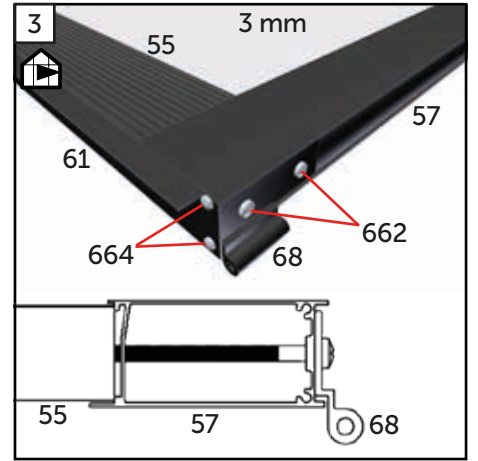
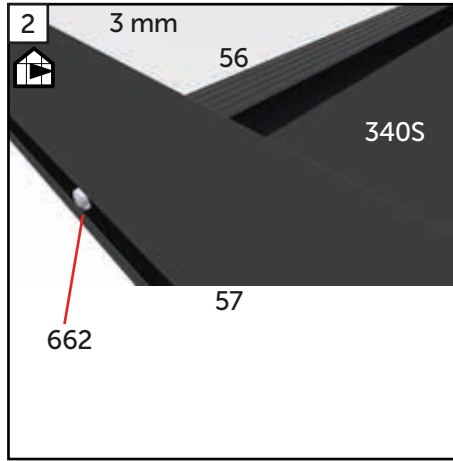
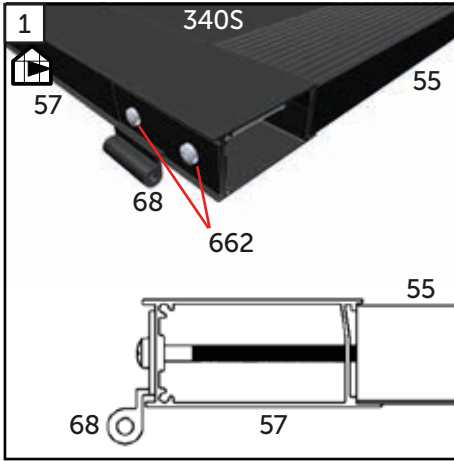

# Dør - Door - Tür - Dörr - Porte - Deur - Ovi - Drzwi

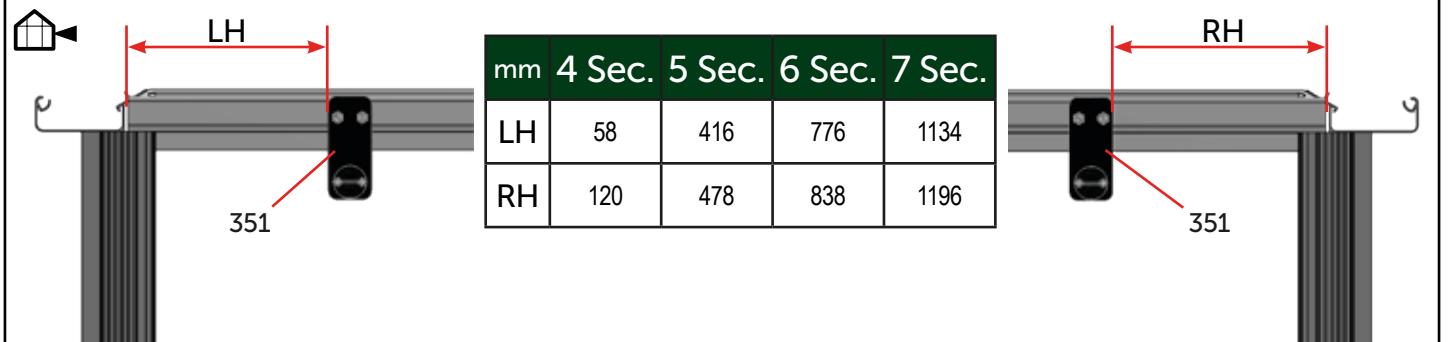
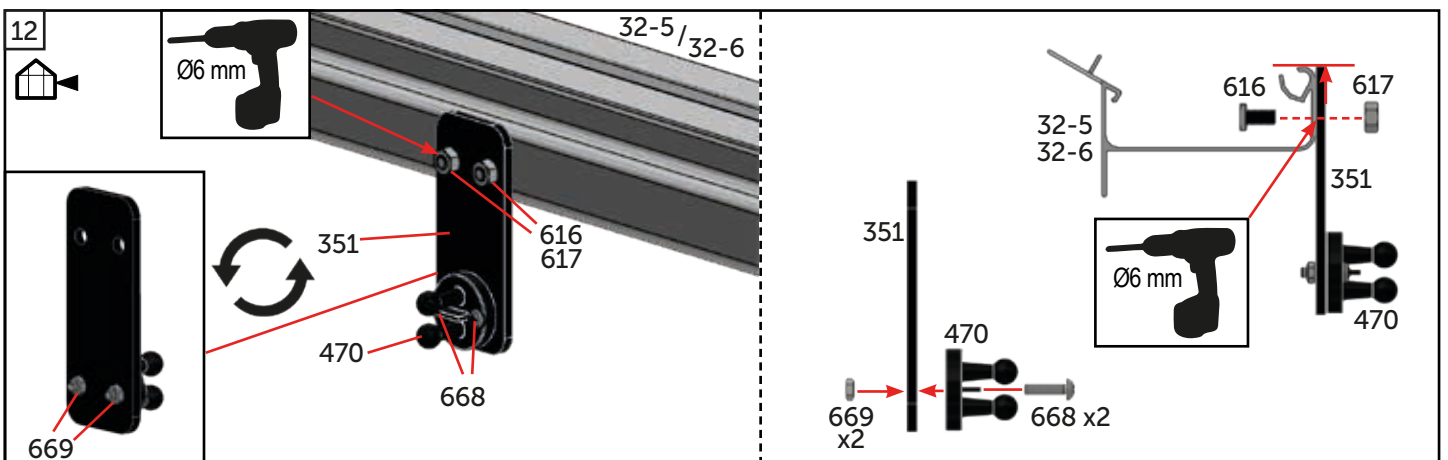
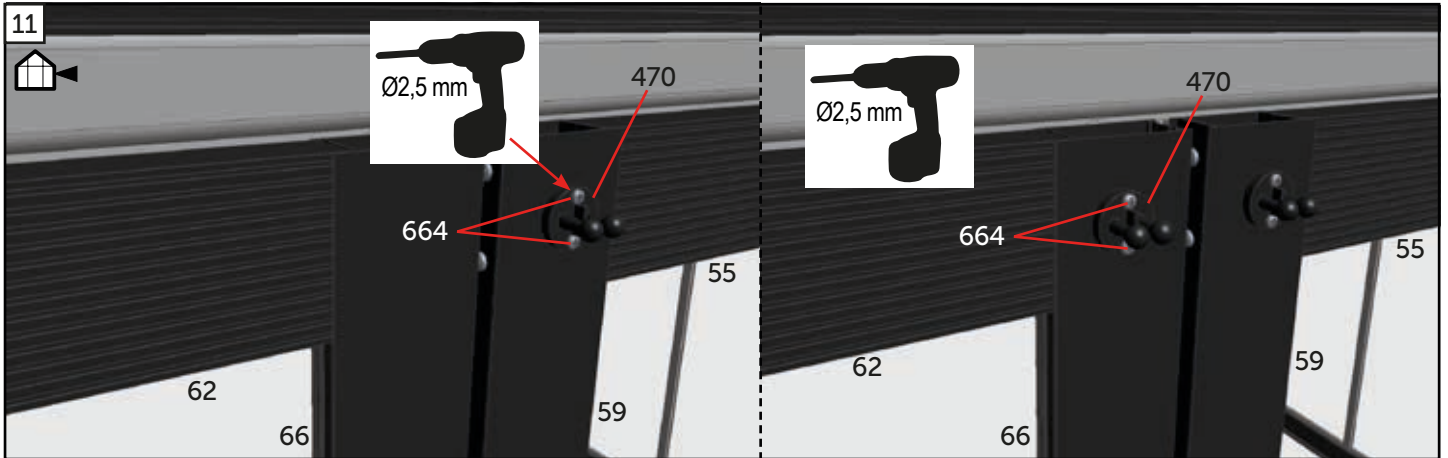



# TILBEHØR · ACCESSORIES · ZUBEHÖR · ACCESSOIRES



Juliana planteophængsøjer  
Juliana plant rings  
Juliana Aufhängevorrichtungen für Pflanzen  
Éillet pour suspension de plantes Juliana



Juliana skyggenet  
Juliana shade net  
Juliana Schattierungsnetz  
Voile d'ombrage Juliana



Juliana plantespiraler  
Juliana plant spirals  
Juliana Pflanzenspiral  
Tuteur spirale Juliana



Juliana Vanlet automatisk vandings- og gødningsanlæg  
Juliana Vanlet automatic drip irrigation and fertilizer system  
Juliana Vanlet automatische Bewässerungs- und Düngungsanlage  
Système d'arrosage automatique Juliana Vanlet



Juliana plantehylde sort  
Juliana plant shelve black  
Juliana Pflanzen Regale Schwarz  
Étagère mobile Juliana

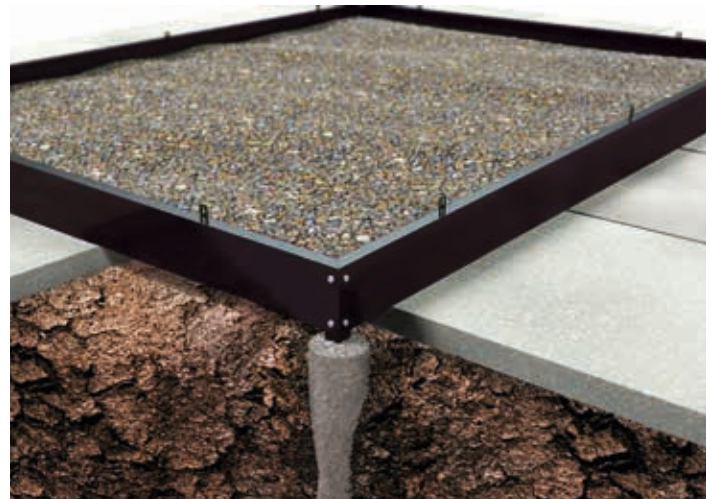

Juliana fundament  
Juliana base  
Juliana Fundament  
Embase Juliana

COMPACT · 5,0 m<sup>2</sup> · 6,6 m<sup>2</sup> · 8,2 m<sup>2</sup>



PREMIUM · 8,8 m<sup>2</sup> · 10,9 m<sup>2</sup> · 13,0 m<sup>2</sup>



GARTNER · 16,2 m<sup>2</sup> · 18,8 m<sup>2</sup> · 21,4 m<sup>2</sup>



VERANDA · 4,4 m<sup>2</sup> · 6,6 m<sup>2</sup> · 12,9 m<sup>2</sup>



ORANGERI · 15,2 m<sup>2</sup>



OASE · 8,8 m<sup>2</sup> · 13,5 m<sup>2</sup>



GRAND OASE · 13,0 m<sup>2</sup> · 18,8 m<sup>2</sup>



URBAN · 0,16 m<sup>2</sup> · 0,31 m<sup>2</sup> · 0,32 m<sup>2</sup>



**JULIANA A/S**

Sivlandvænget 29 · 5260 Odense S · Denmark

Tel: +45 66 11 18 11 · mail@juliana.com

Juliana.com



# Jubii 60

## Ekstra dørsæt - Extra door kit - Extra Tür Set

Extra dörrar set - Kit de porte supplémentaire - Extra doos deuronderdelen

Ylimääräinen ovisarja - Dodatkowy zestaw drzwi

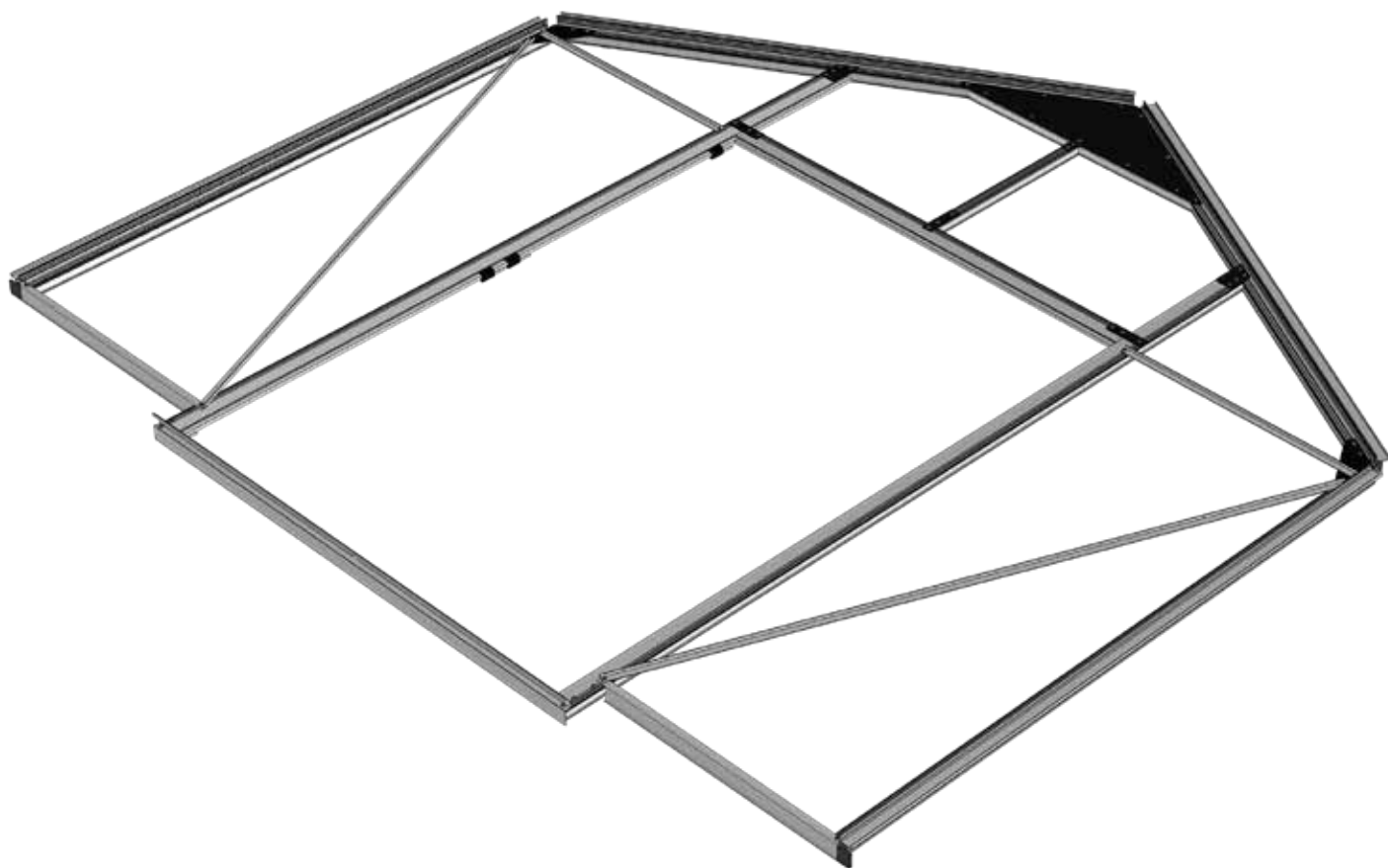





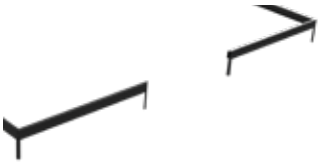
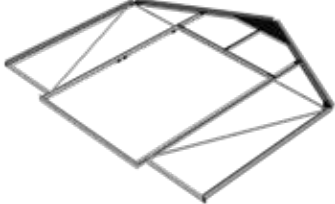
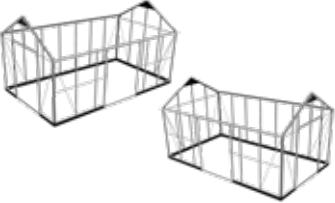
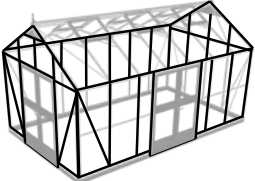
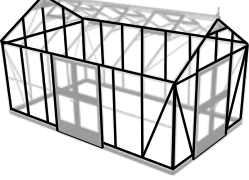

11032024 - 1.02

Montagevejledning · Assembly Instructions · Montageanleitung  
Monteringsanvisning · Instructions de montage · Montagehandleiding  
Kokoamisohje · Instukcja montażu

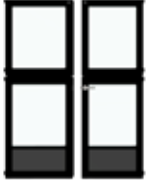

Oversigt - Overview - Übersicht - Översikt - Détails  
 Overzicht - Sisällys - Zawartość

	
	6
	7 - 11
	12
	13 - 15
	16 - 18
	19
	 
	20 - 25

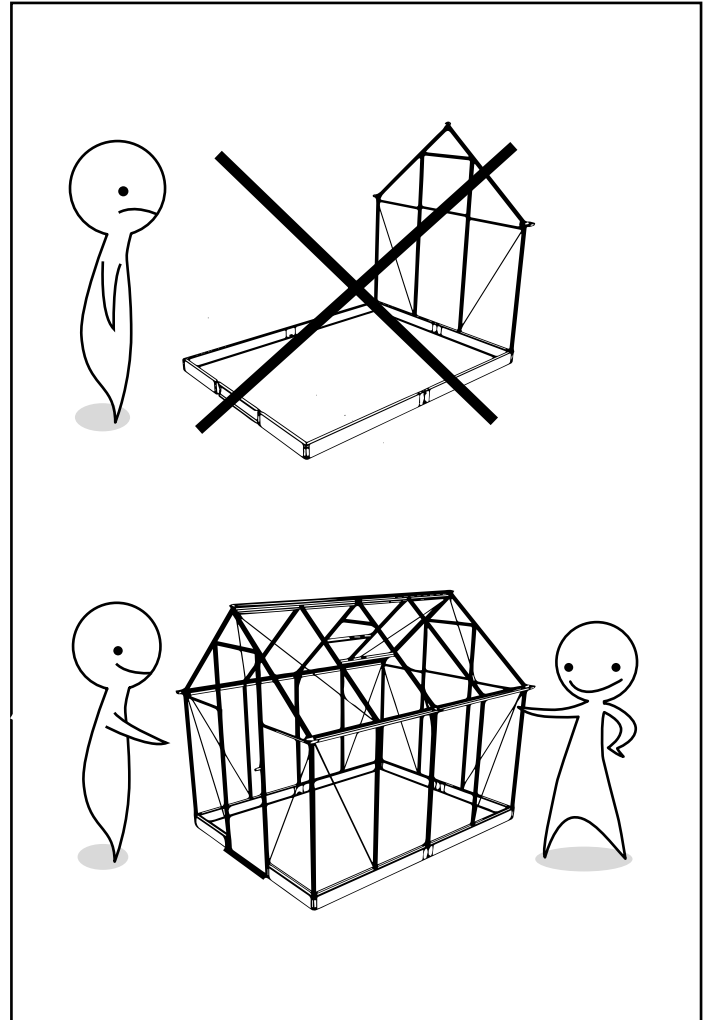

# Oversigt - Overview - Übersicht - Översikt - Détails Overzicht - Sisällys - Zawartość

Profiler - Profiles - Profile		
#		Qty.
740	00510740S	2
1468	00511468S	1
341S	00310341S	1
342S	00310342S	1
00	13-20301468-00S	1
08	13-20151404-08S	1
09	13-10020742-09S	1
10	13-10020742-10S	1
11	13-20152368-11S	1
12	13-20152368-12S	1
19	13-10300730-19S	2
81	13-20130588-81S	1

3 mm - Hærdet glas - Toughened glass - Sicherheitsglas		
#		Qty.
G	00281507	2
H	00281508	2
I	00281583	2

Dør - Door - Tür		
#	Box 8	Qty.
55	13-20170517-55S	4
56	13-20160517-56S	1
57	13-20221075-57S	1
58	13-20221075-58S	1
59	13-20220812-59S	2
61	13-10020651-61S	1
340S	00310340S	1

Dør - Door - Tür		
#	Box 9	Qty.
59	13-20220812	1
62	13-20170578-62S	4
63	13-20160578-63S	1
64	13-20231075-64S	1
65	13-20221075-65S	1
66	13-20230812-66S	1
67	13-10020712-67S	1
339S	00310339S	1

# Symboler - Symbole - Symbols - Symboles - Symbolen - Symbolit



<b>DK</b> Denne del bruges på side "X".	<b>FR</b> Cette pièce est utilisée à la page «X».
<b>GB</b> This component is used on page "X".	<b>NL</b> Dit deel wordt gebruikt op pagina "X".
<b>DE</b> Dieser Teil verwenden Sie an der Seite „X“.	<b>FIN</b> Tätä osaa käytetään sivulla "X".
<b>SE</b> Denna del används på sidan "X".	<b>PL</b> Część używana na stronie „X”.



<b>DK</b> Sektionen samles i denne rækkefølge.	<b>FR</b> Assembler la section dans cet ordre.
<b>GB</b> Assemble the section in this order.	<b>NL</b> Dat is de volgorde van het monteren.
<b>DE</b> Die Sektion wird in dieser Reihenfolge gesammelt.	<b>FIN</b> Lohkot kootaan tässä järjestyksessä.
<b>SE</b> Sektionen monteras i denna ordning.	<b>PL</b> Sekcję należy montować w tej kolejności.



<b>DK</b> Tallet angiver antal styk / gentagelser af processen.	<b>FR</b> Le chiffre indique le nombre de fois / répétitions de la procédure.
<b>GB</b> The number indicates the quantity / the number of times the process must be repeated.	<b>NL</b> Het getal geeft het aantal stuks / onderdelen van het proces aan.
<b>DE</b> Die Zahl zeigt die Anzahl der Stücke / der Wiederholungen des Prozesses an.	<b>FIN</b> Numero ilmaisee kappaleiden / toistojen määrän.
<b>SE</b> Siffran anger antal gånger / repetitioner av processen.	<b>PL</b> Liczba wskazuje liczbę sztuk / powtórzeń procesu.



<b>DK</b> Korrekt samling / forkert samling.	<b>FR</b> Assemblage correct / incorrect.
<b>GB</b> Correct assembly / wrong assembly.	<b>NL</b> Correcte montage / incorrecte montage.
<b>DE</b> Die korrekte Montage / die verkehrte Montage.	<b>FIN</b> Oikea kokoonpano / väärä kokoonpano.
<b>SE</b> Korrekt montering / felaktig montering.	<b>PL</b> Prawidłowy montaż / nieprawidłowy montaż.



<b>DK</b> Billedet viser samlingen indefra / udefra.	<b>FR</b> Ce symbole montre l'assemblage depuis l'intérieur / l'extérieur de la serre.
<b>GB</b> The image shows the assembly from the inside / outside.	<b>NL</b> De afbeelding toont het frame van binnen / buiten.
<b>DE</b> Das Bild zeigt die Montage von innen / von außen.	<b>FIN</b> Kuvassa näytetään kokoonpano sisä- / ulkopuolelta.
<b>SE</b> Bilden visar monteringen från insidan / utsidan.	<b>PL</b> Zdjęcie przedstawia zmontowane elementy od wewnątrz / z zewnątrz.



<b>DK</b> Møtrikken løsnes / skrues af og genbruges.
<b>GB</b> Loosen / unscrew the bolt and reuse it.
<b>DE</b> Lösen Sie die Schraubenmutter und wiederverwerten Sie sie.
<b>SE</b> Muttern lossas / vskruvas loss och återanvänds.
<b>FR</b> Desserrer / enlever l'écrou et le réutiliser.
<b>NL</b> De moer wordt losgemaakt / losgeschroefd en gerecycled.
<b>FIN</b> Mutteri irrotetaan ja kierrätetään.
<b>PL</b> Poluzować / odkręcić nakrętkę i użyć jej ponownie.



<b>DK</b> Vær opmærksom på justering / retning af profiler.
<b>GB</b> Please note the adjustment / direction of the profiles.
<b>DE</b> Beachten Sie die Justierung / die Richtung von den Profilen.
<b>SE</b> Var uppmärksam på profilernas justering / riktning.
<b>FR</b> Attention à l'ajustement / l'orientation des profilés !
<b>NL</b> Let op de uitlijning / richting van de profielen.
<b>FIN</b> Kiinnitä huomiota profiilien kohdistukseen / suuntaukseen.
<b>PL</b> Zwrócić uwagę na ustawienie / orientację profili.



<b>DK</b> Denne del kasseres.
<b>GB</b> Discard this component.
<b>DE</b> Dieser Teil kassieren Sie.
<b>SE</b> Denna del kasseras.
<b>FR</b> Jeter cette pièce.
<b>NL</b> Dit deel wordt weggegooid.
<b>FIN</b> Tämä osa hylätään.
<b>PL</b> Część przeznaczona do utylizacji.

# Fundament - Base - Embase - Fundering - Perustus

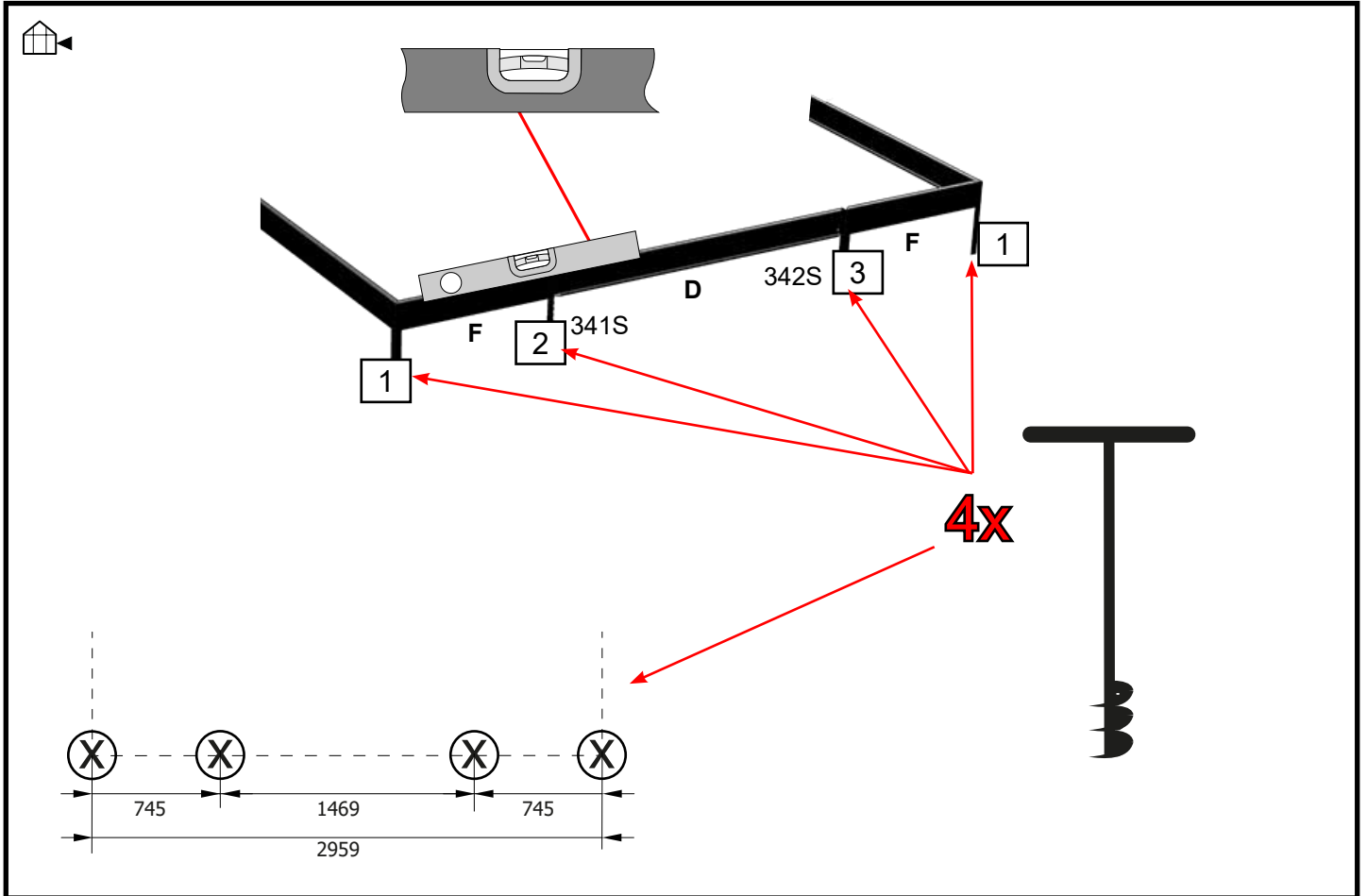



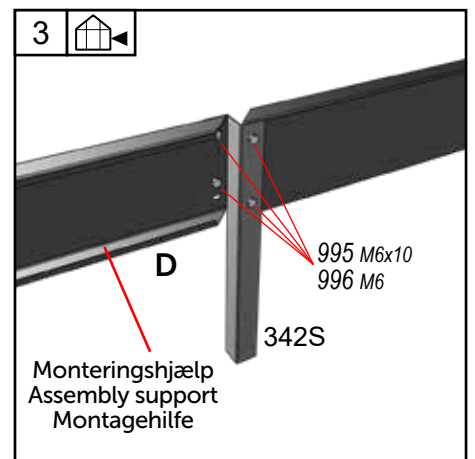
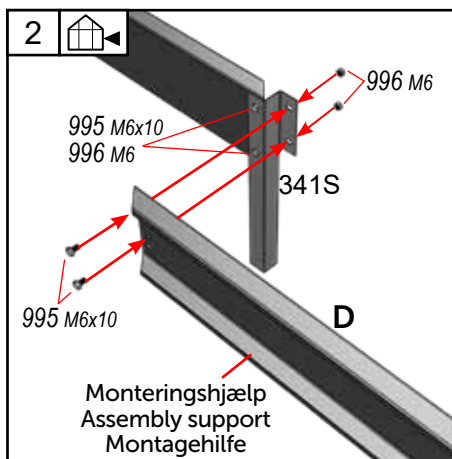
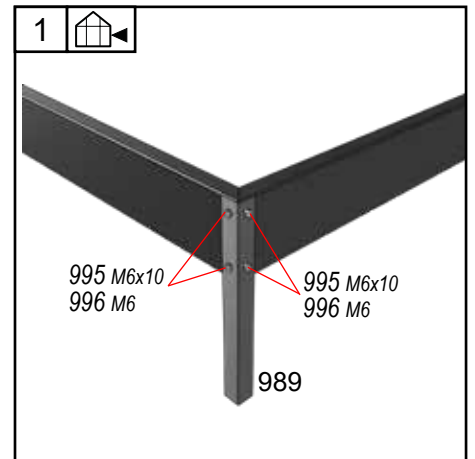
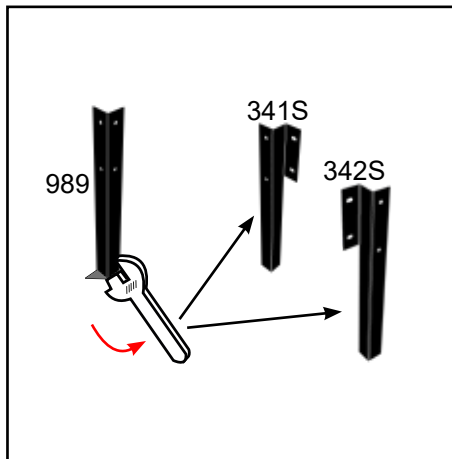



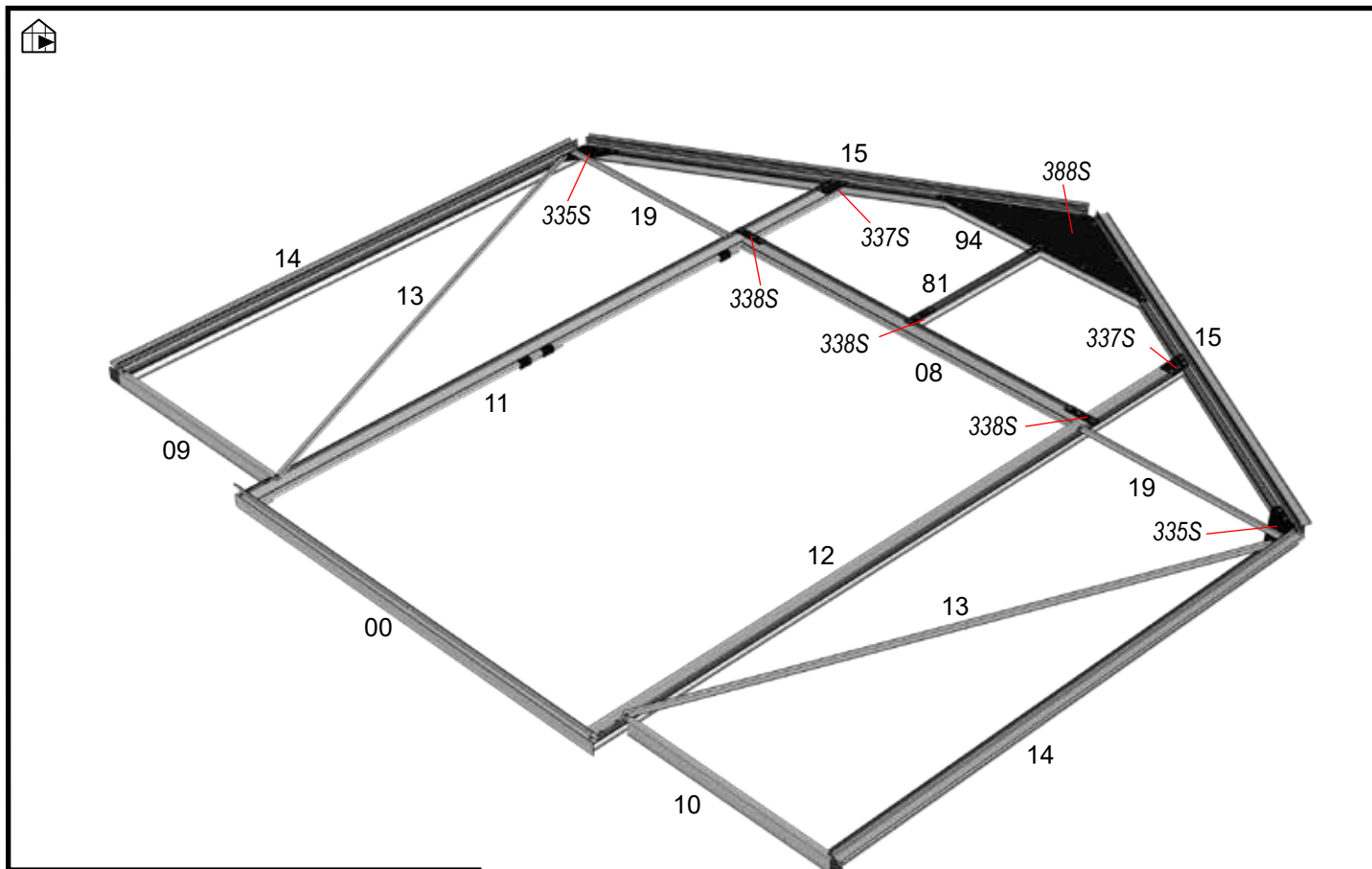









	#	mm	Qty
	F	740	2
	D	1468	1
	341S	345	1
	342S	345	1
	995	M6x10	12
	996	M6	12
	280	M6	8



# Gavl - Gable - Giebel - Gavel - Pignon - Gevel - Päätty - Szczyt



	#	mm	Qty.
	00	1468	1
	08	1404	1
	09	742	1
	10	742	1
	11	2368	1
	12	2368	1
	19	730	2
	81	588	1
<b>Fittings</b>			
	05	-	4
	06	-	4
	616	M6	76
	617	M6X11	76
	280	M6	76
	337S	-	2
	338S	-	3

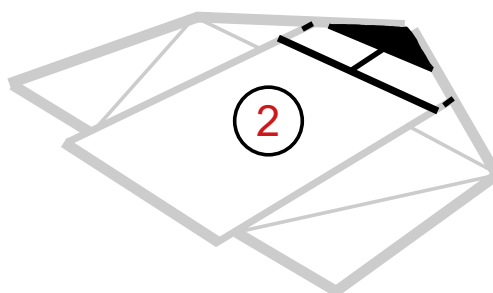
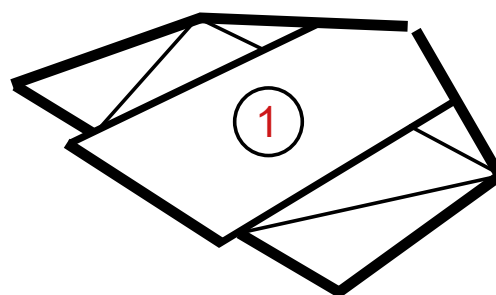

# Gavl - Gable - Giebel - Gavel - Pignon - Gevel - Päätty - Szczyt

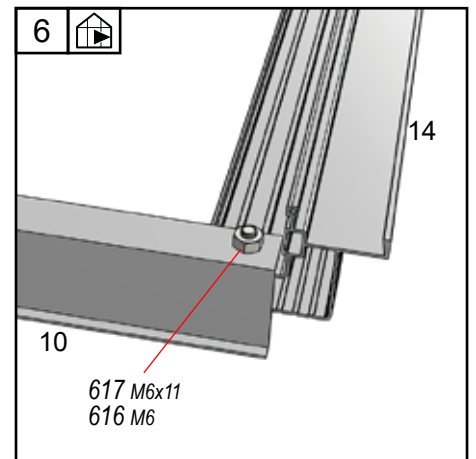
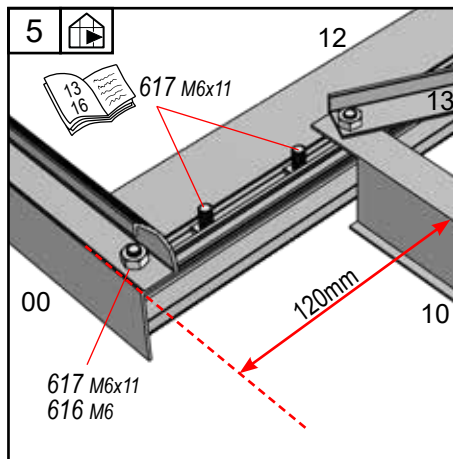
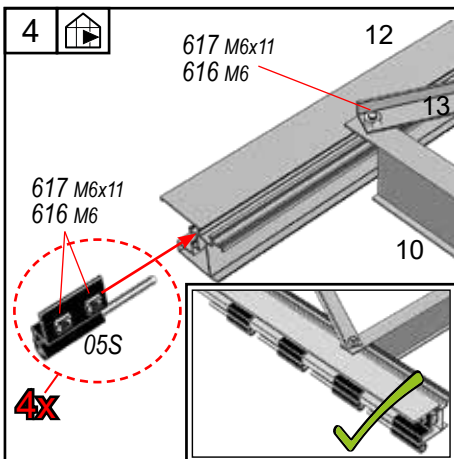
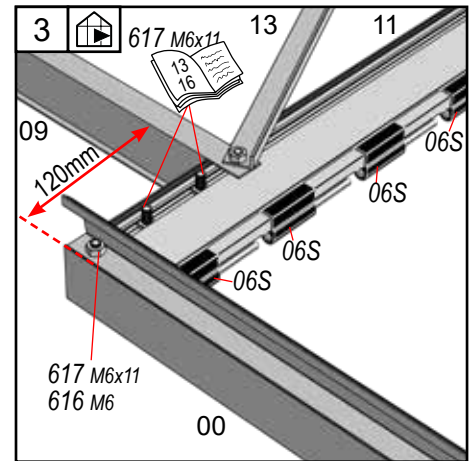
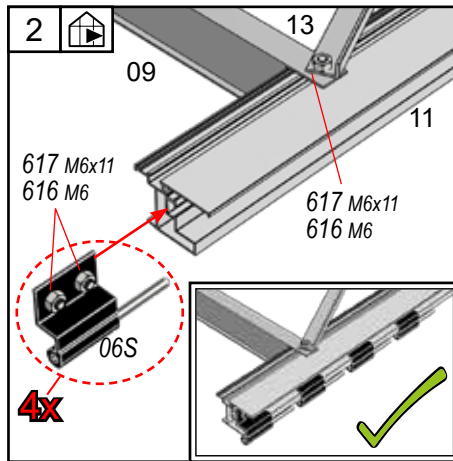
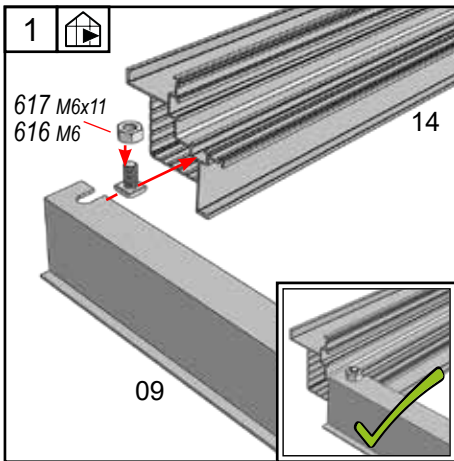
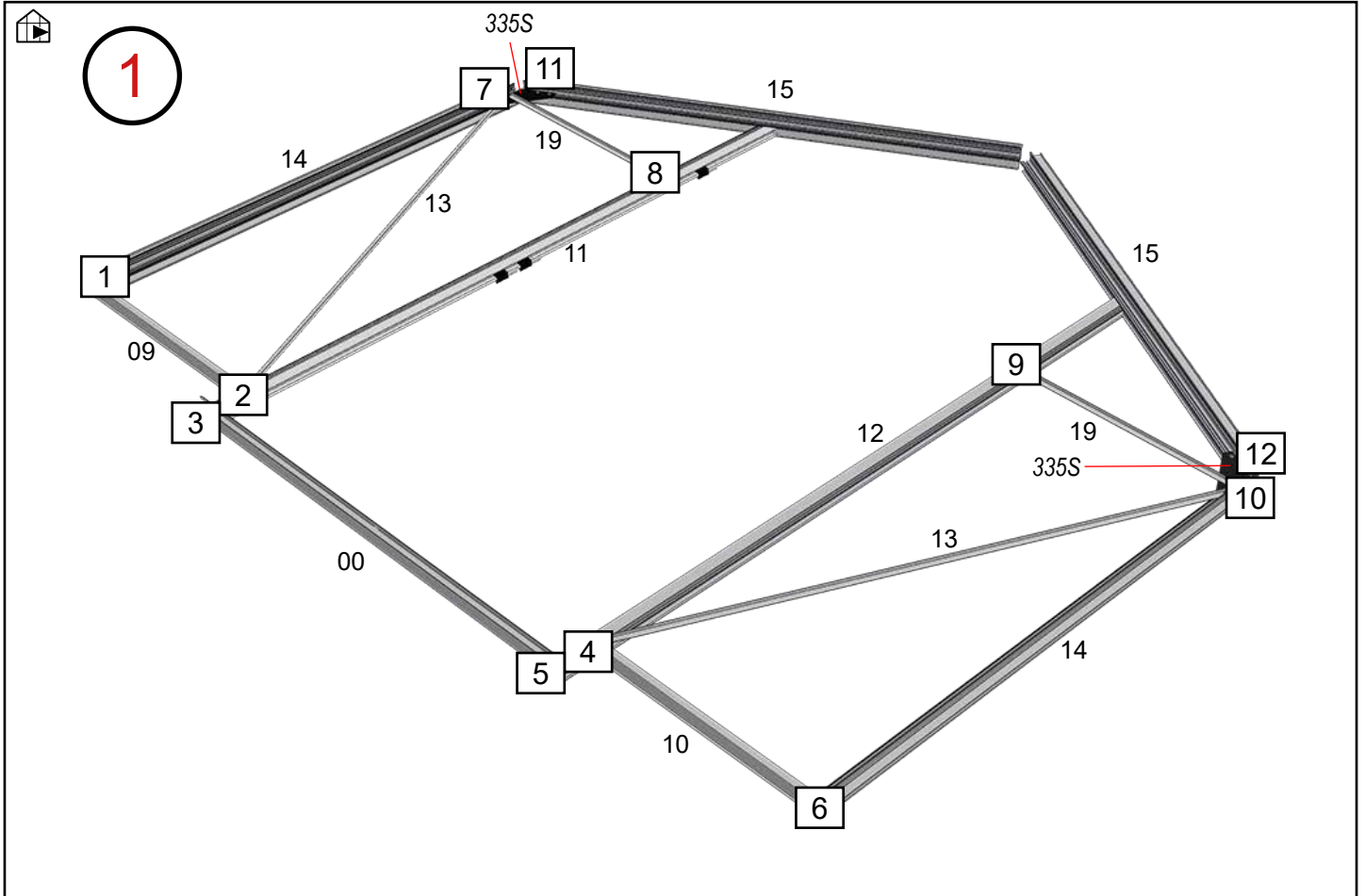

# Gavl - Gable - Giebel - Gavel - Pignon - Gevel - Päätty - Szczyt

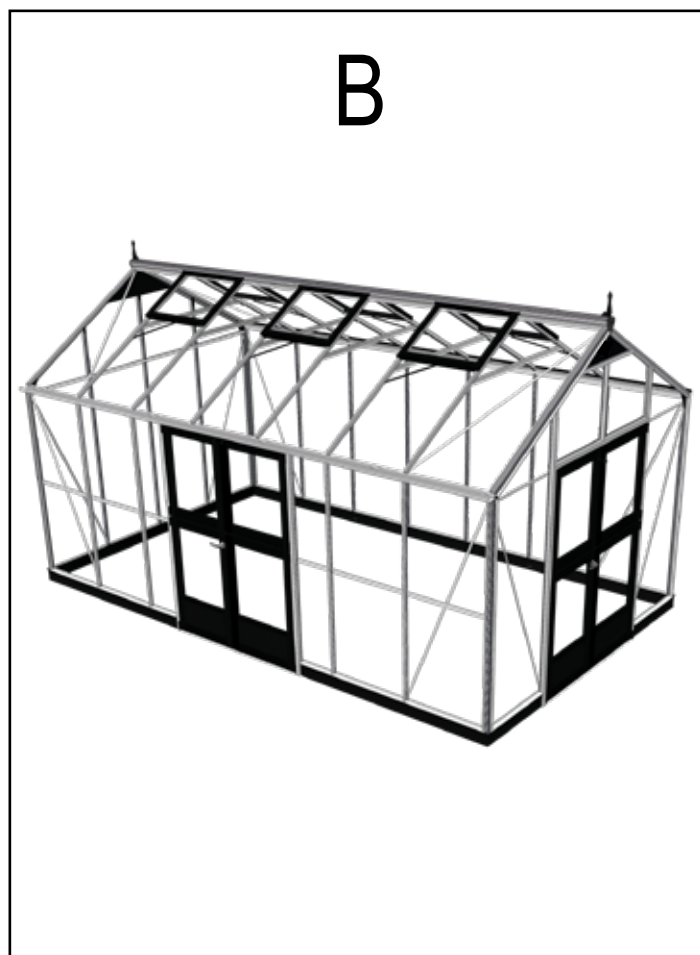
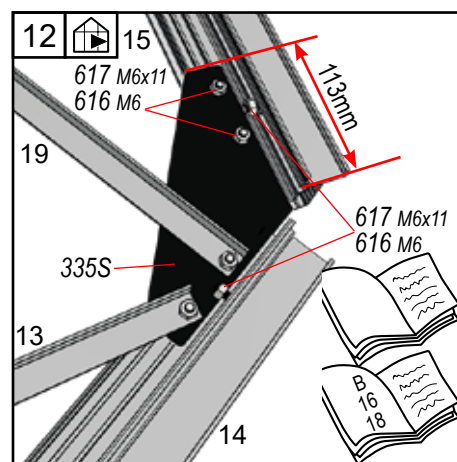
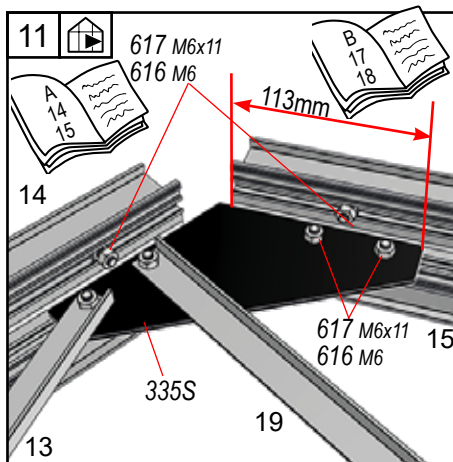
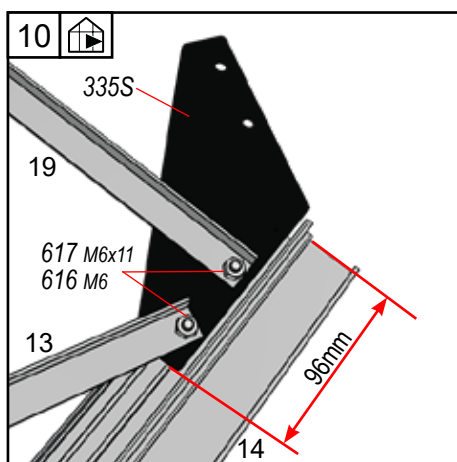
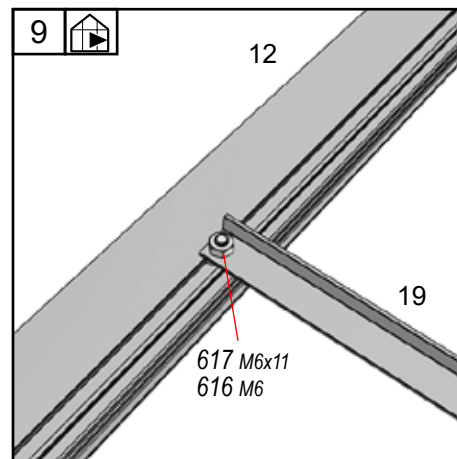
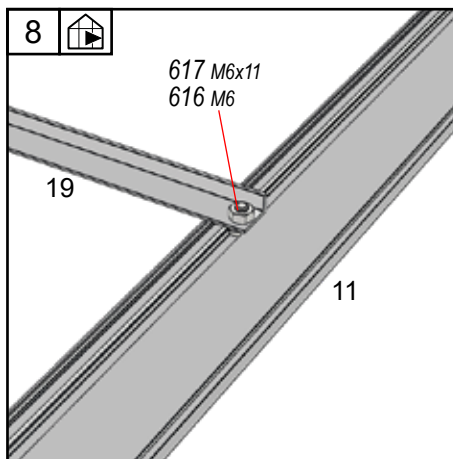
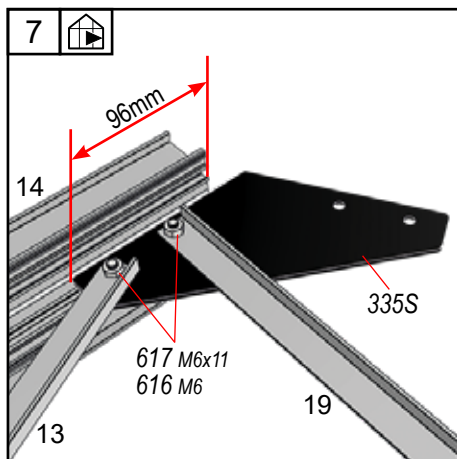

Gavl - Gable - Giebel - Gavel - Pignon - Gevel - Päätty - Szczyt

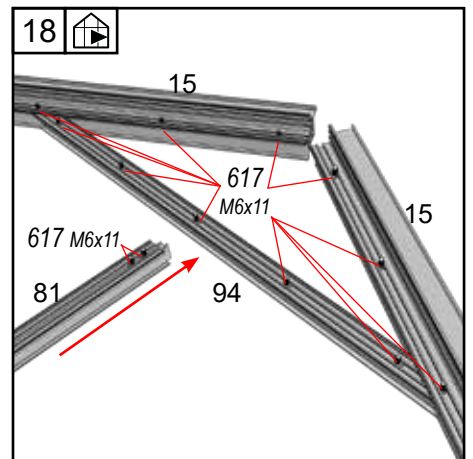
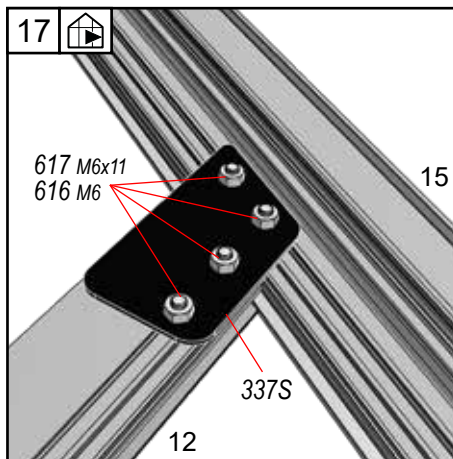
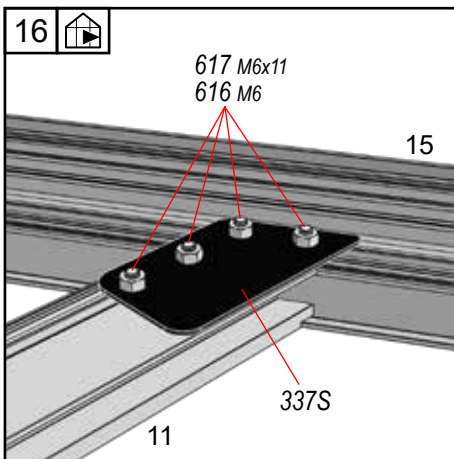
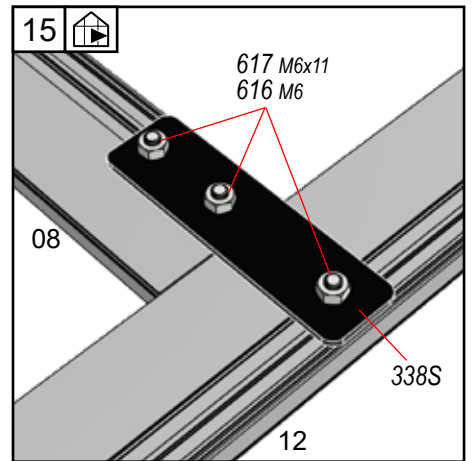
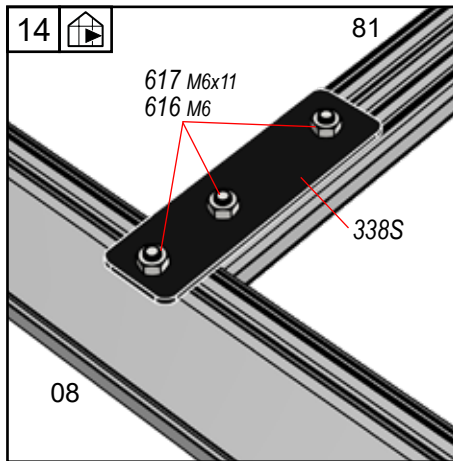
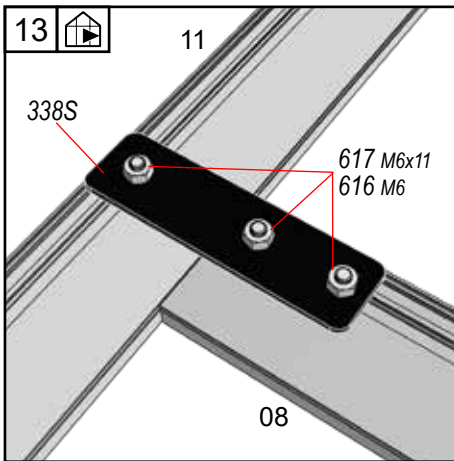
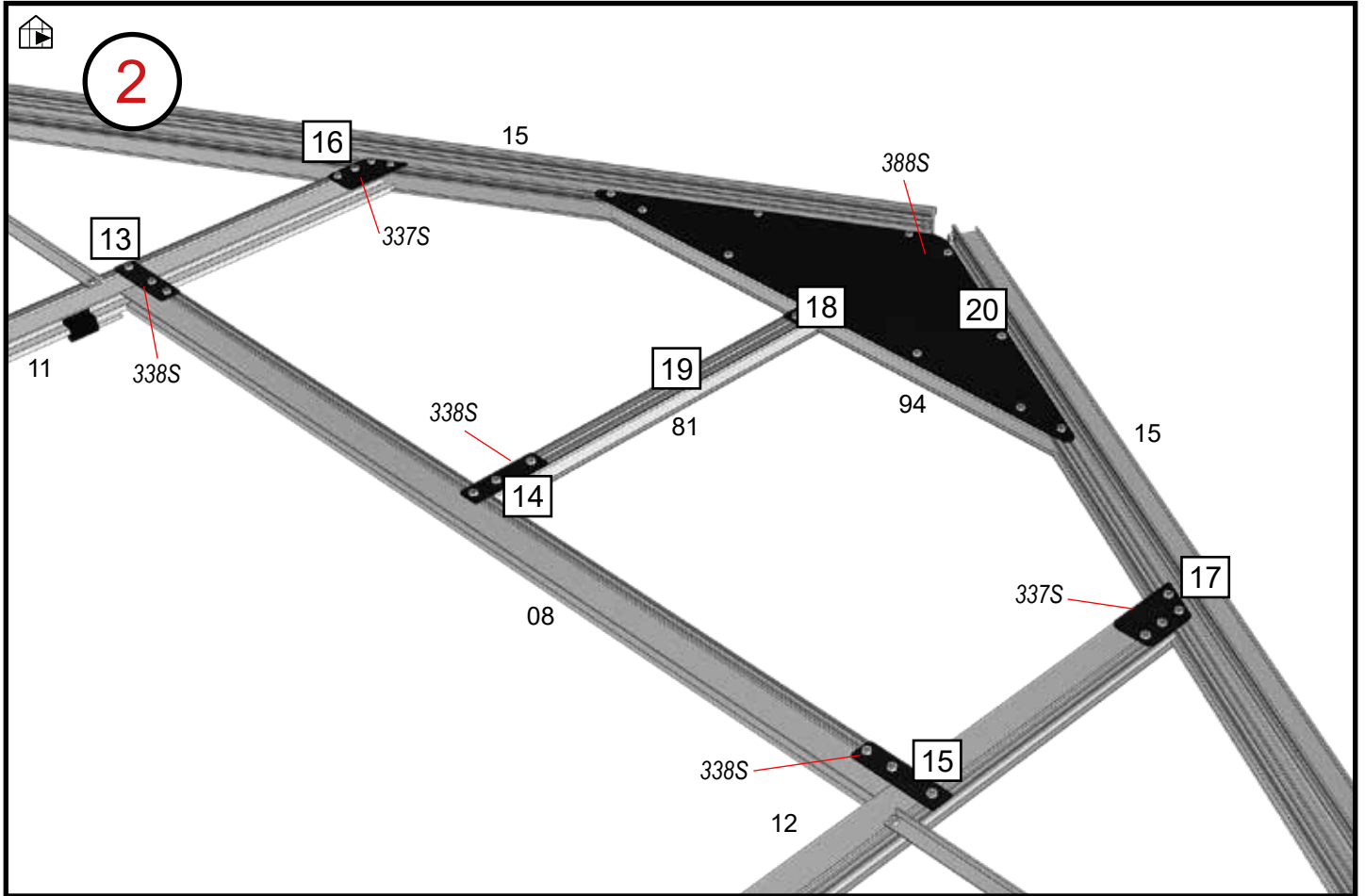

Gavl - Gable - Giebel - Gavel - Pignon - Gevel - Päätty - Szczyt

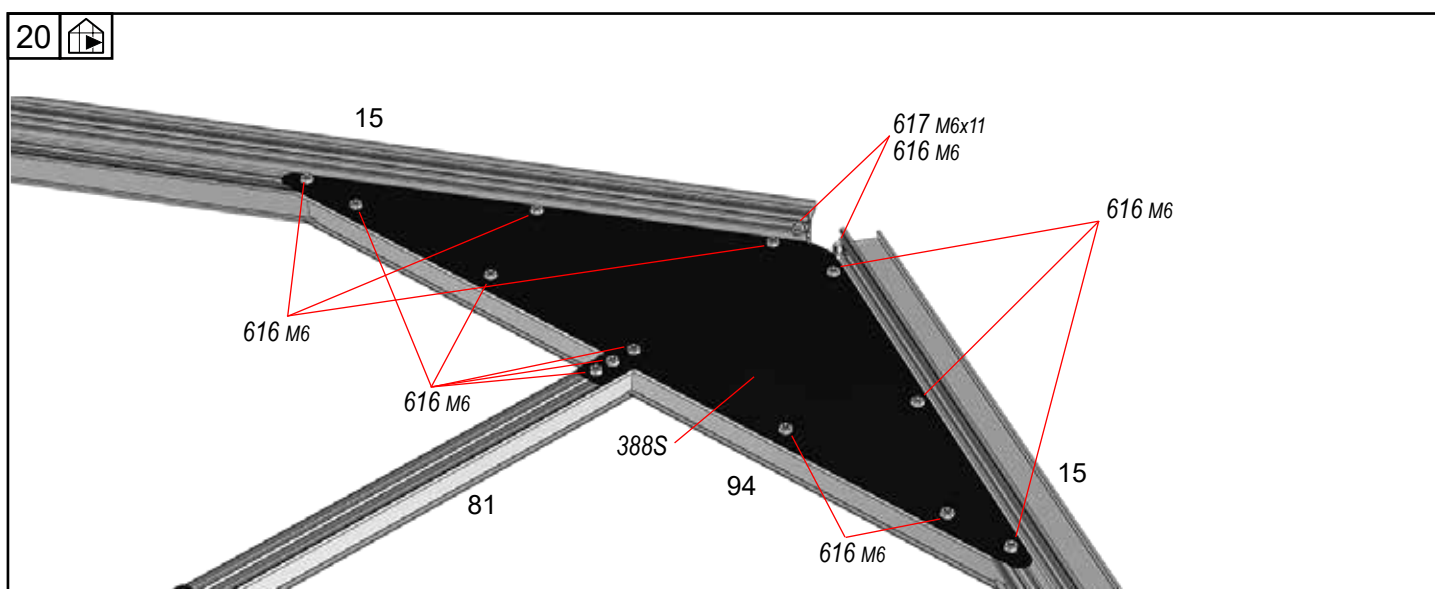
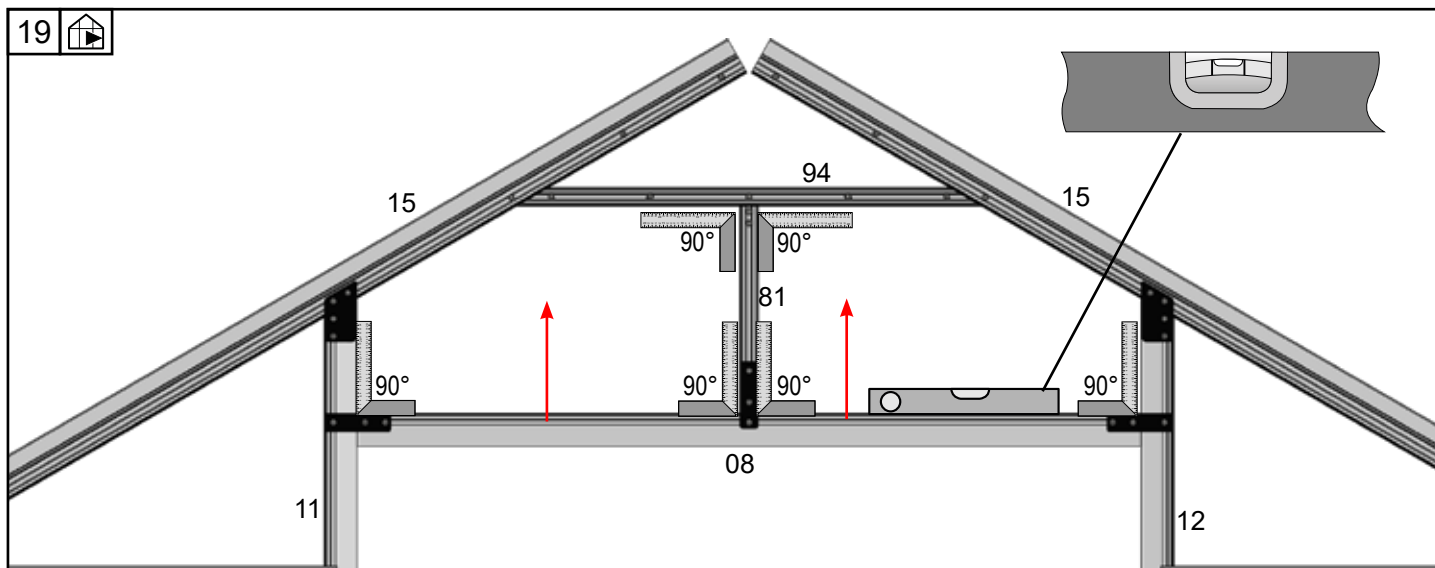

For - Front - Vorder - Front - Devant - Voor - Ovi - Przednia  
Side - Seite - Sida - Côté - Pagina - Puoli - Strona



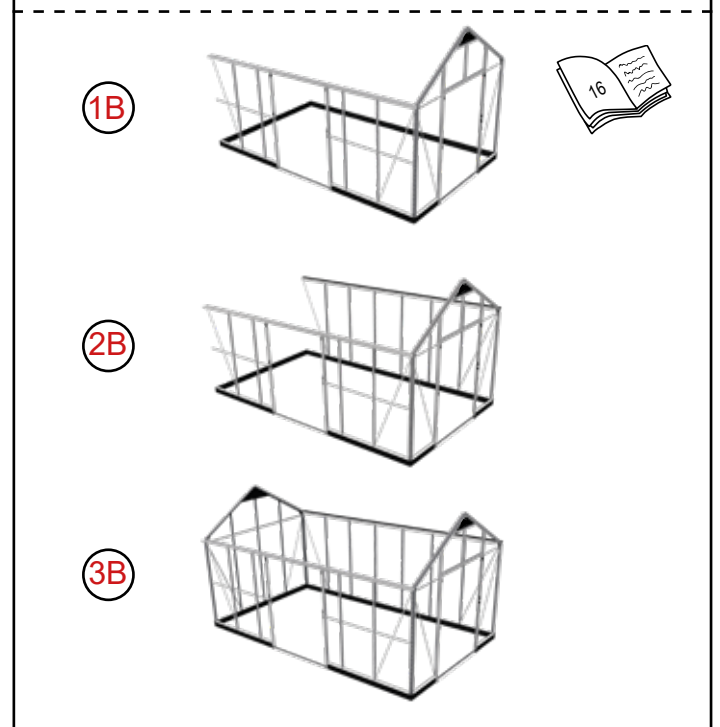
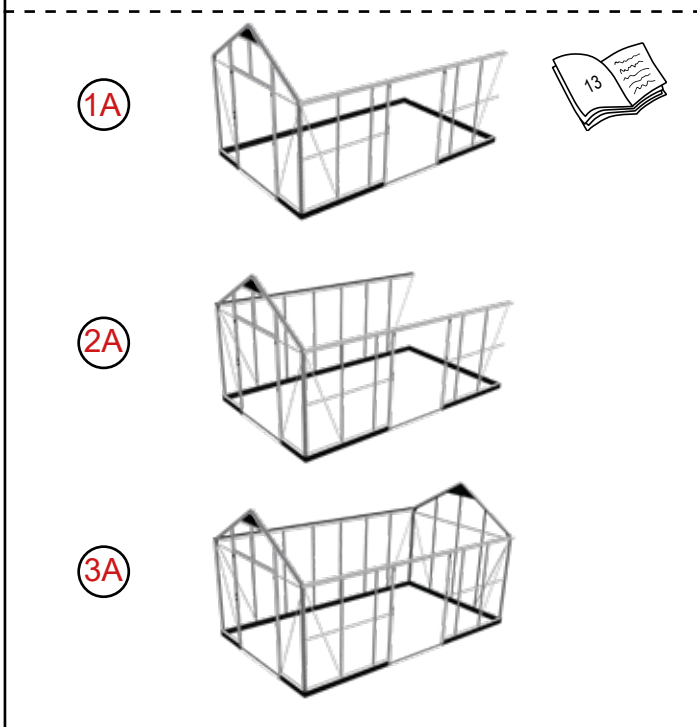
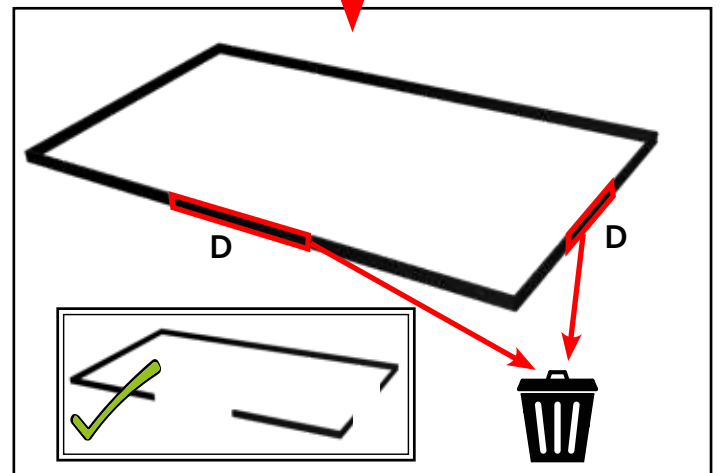
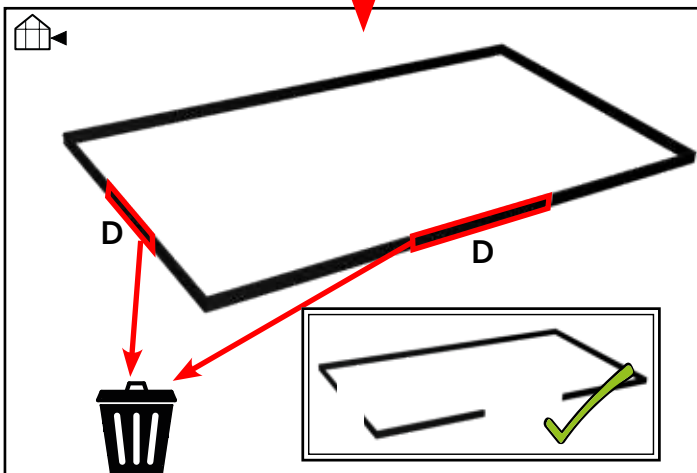
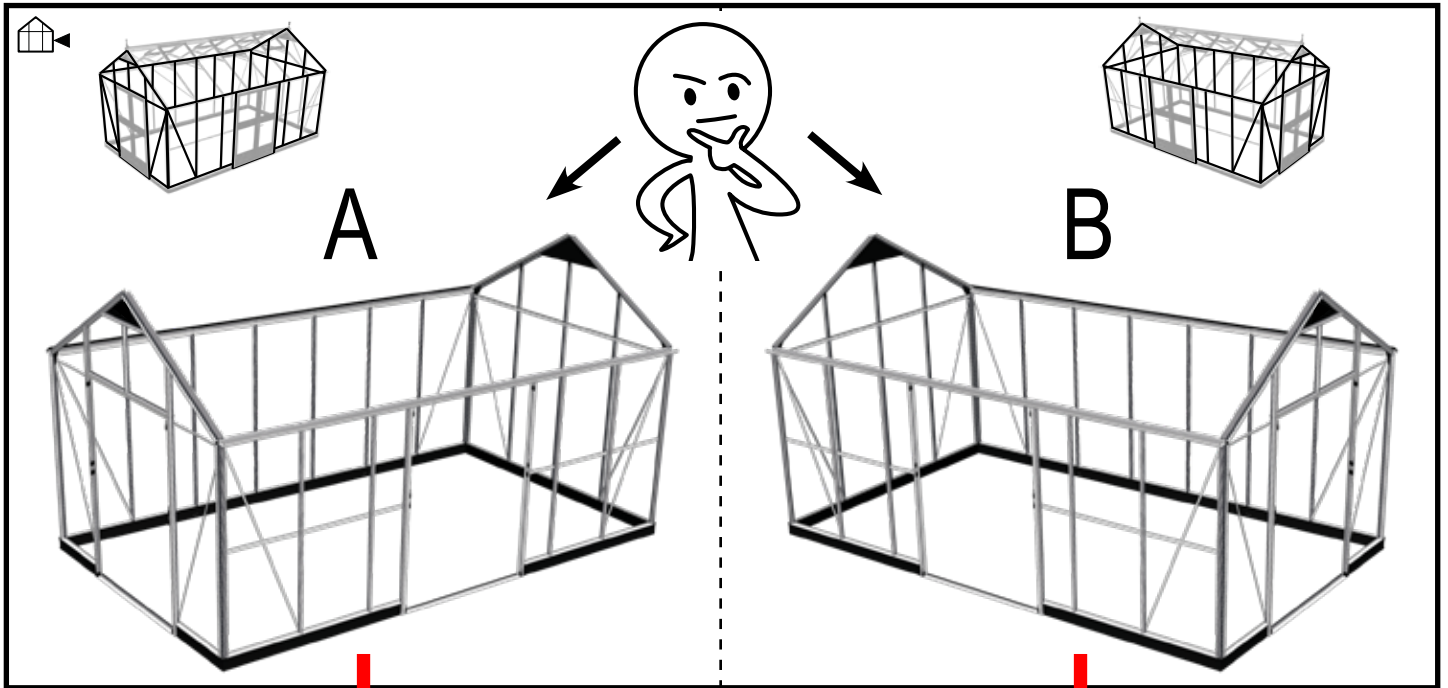

Samling - Assembly - Verbindung - Församling - Assemblage -  
Kokoaminen - Montaż stelaża

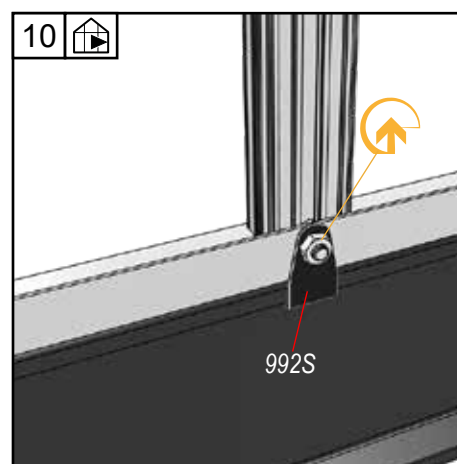
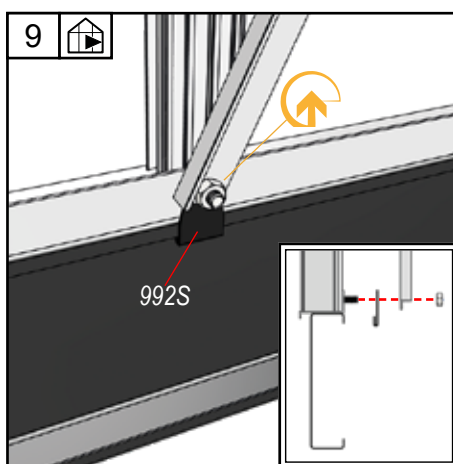
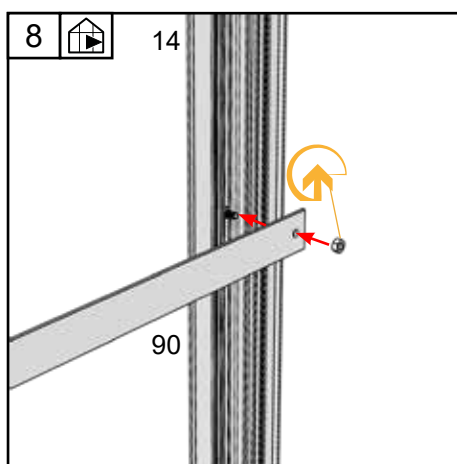
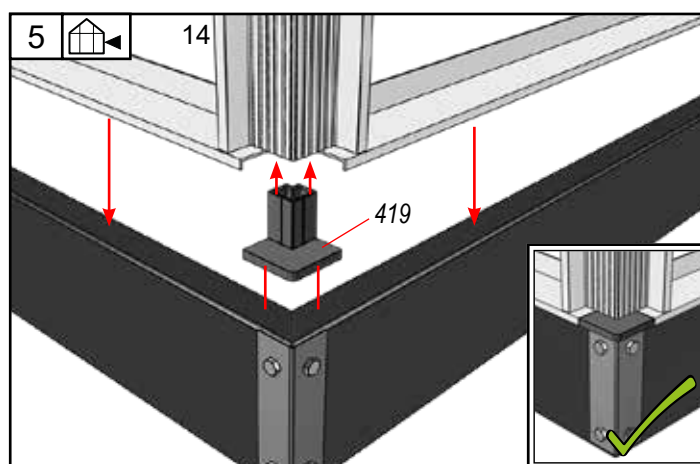
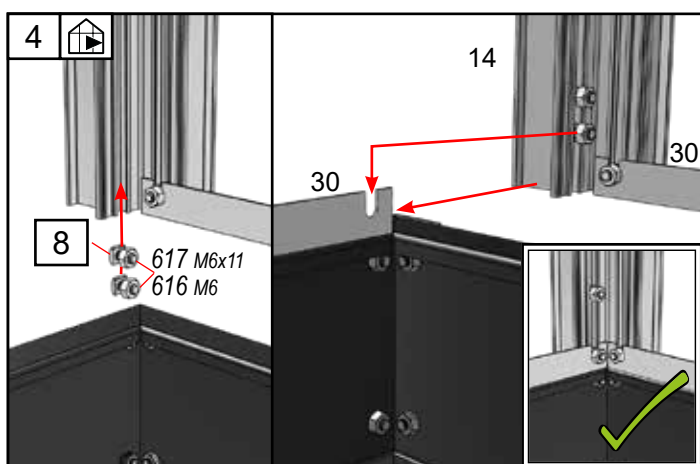
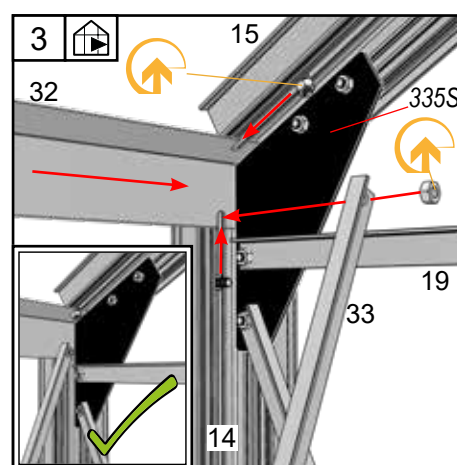
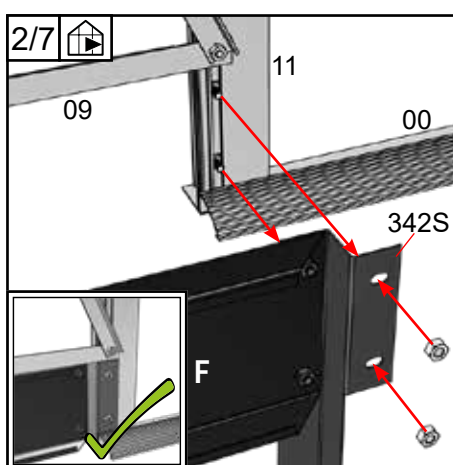
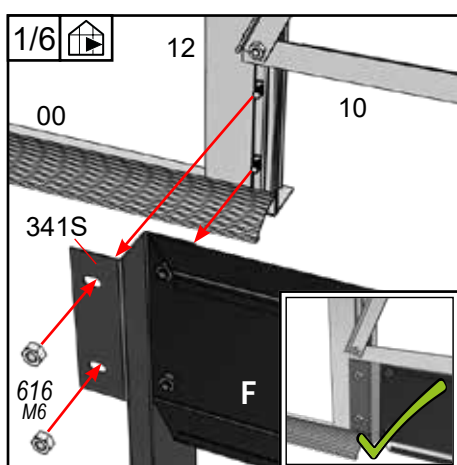
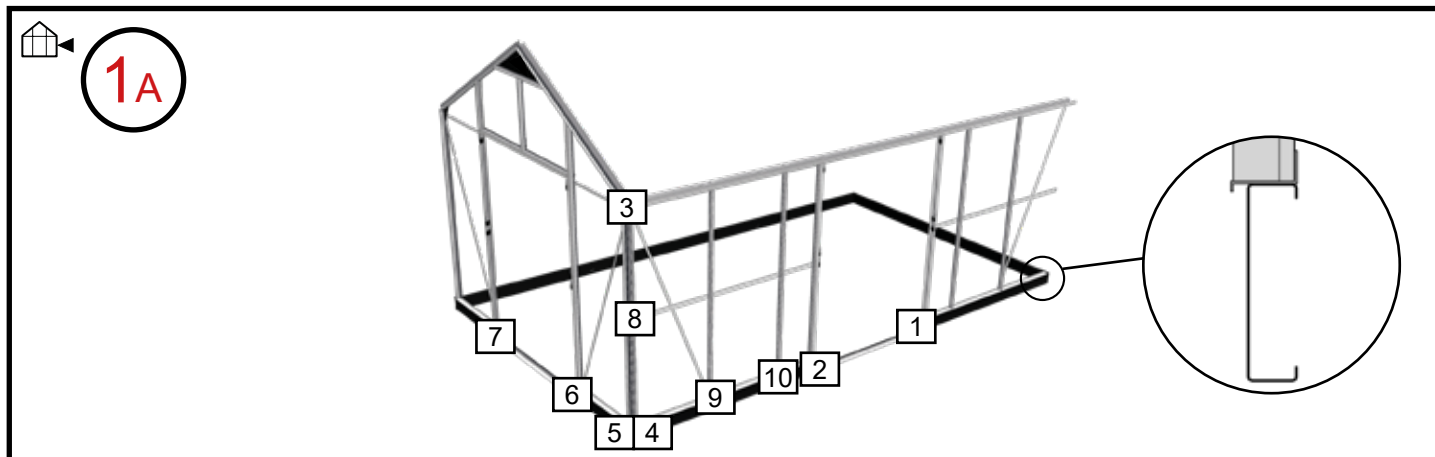

Samling - Assembly - Verbindung - Församling - Assemblage -  
Kokoaminen - Montaž stelaža

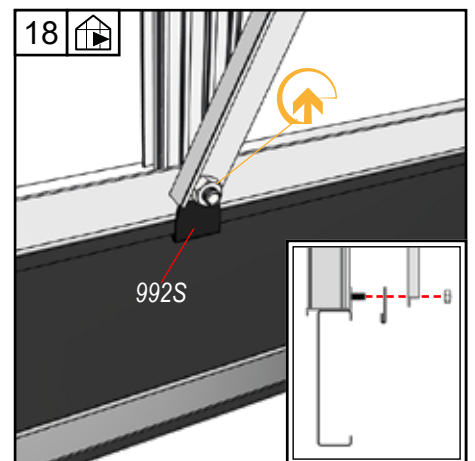
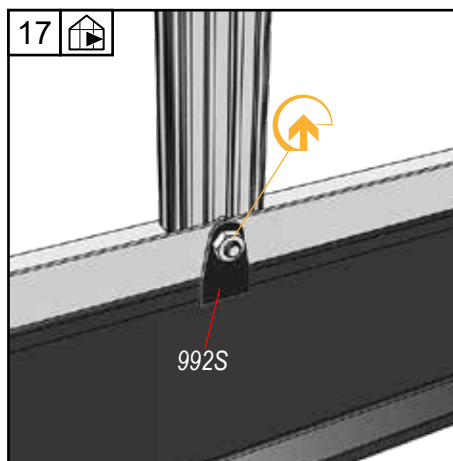
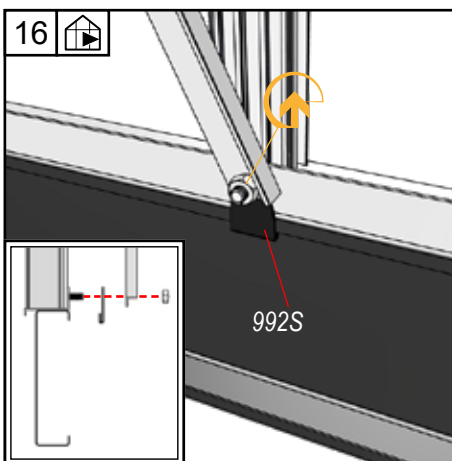
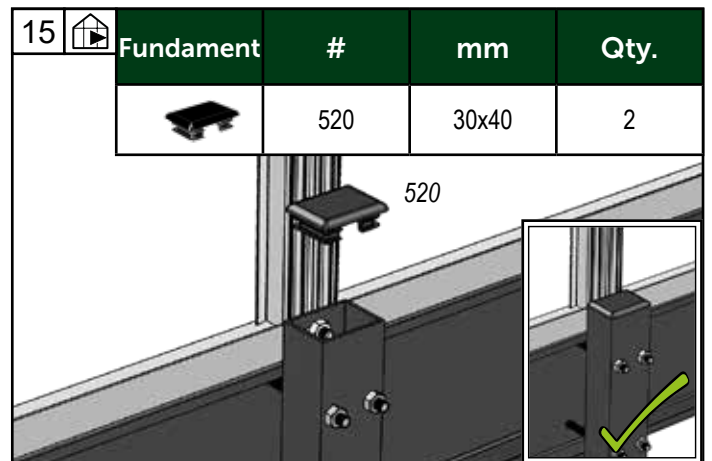
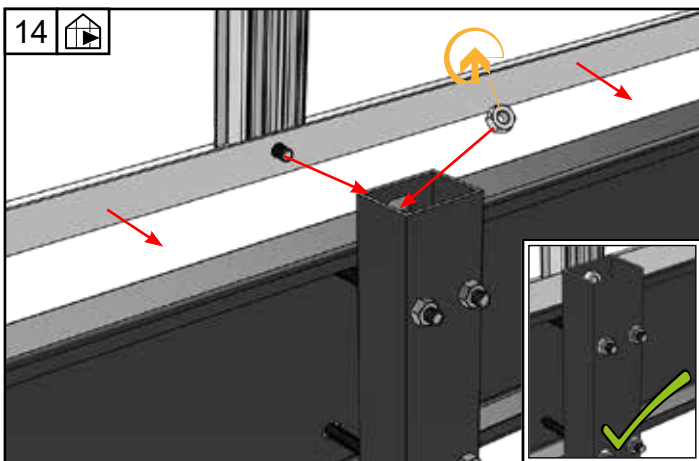
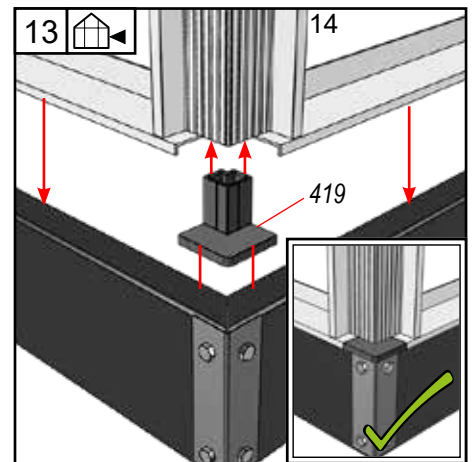
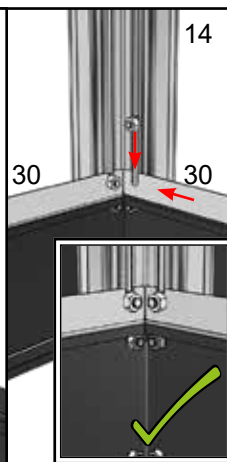
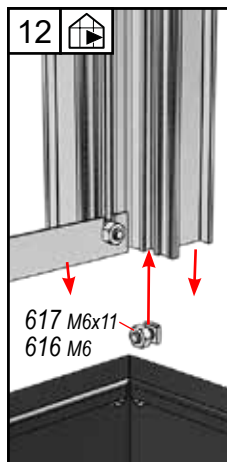
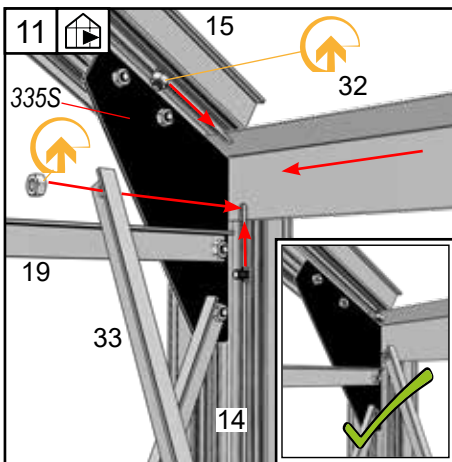
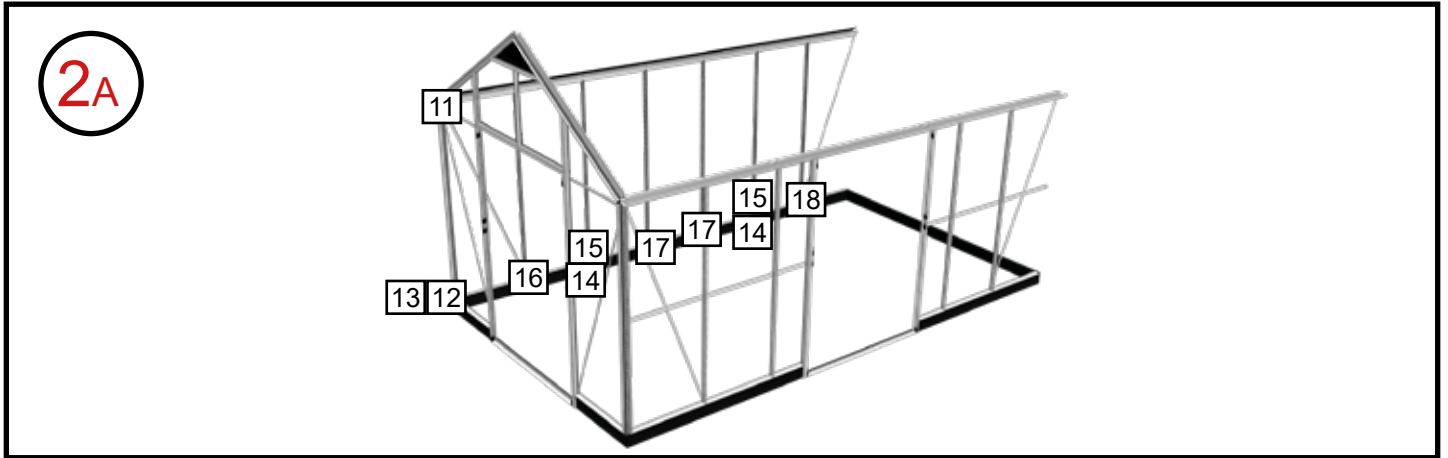

Samling - Assembly - Verbindung - Församling - Assemblage -  
Kokoaminen - Montaž stelaža

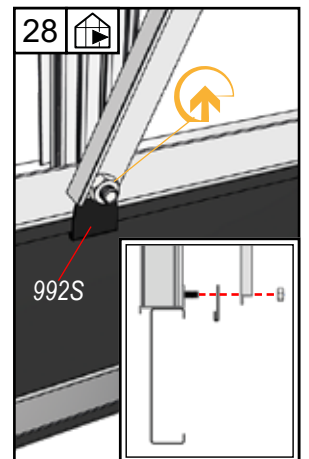
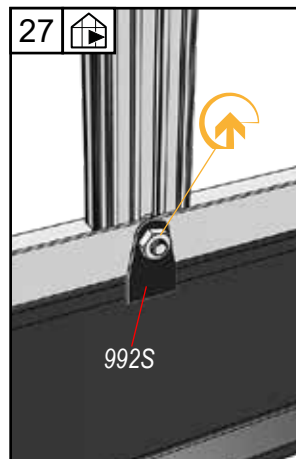
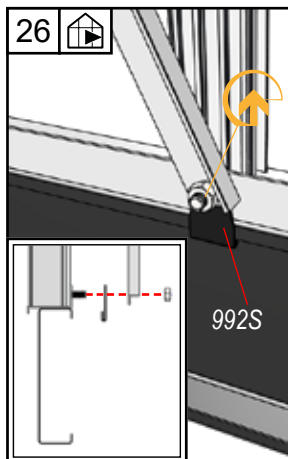
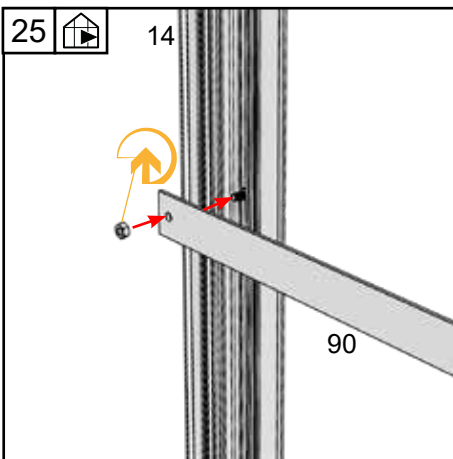
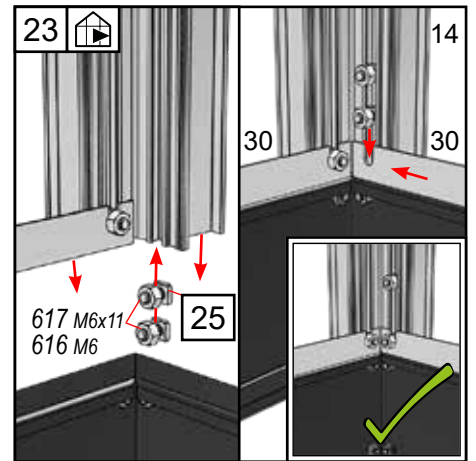
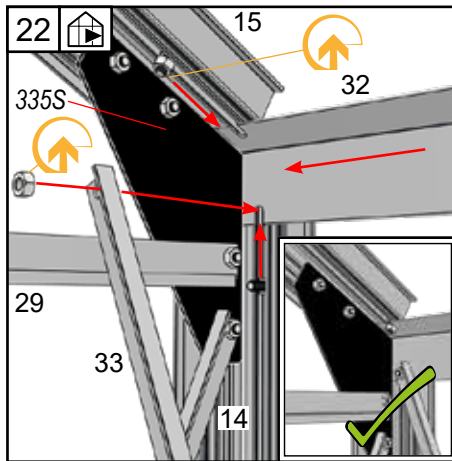
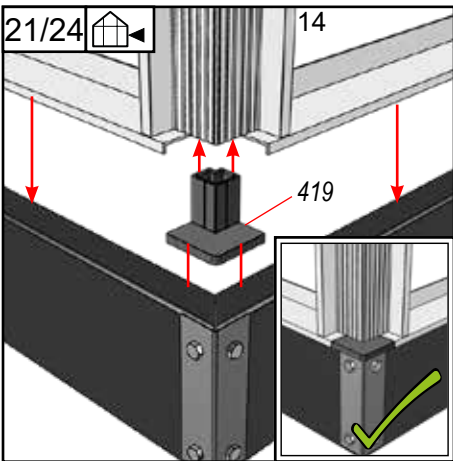
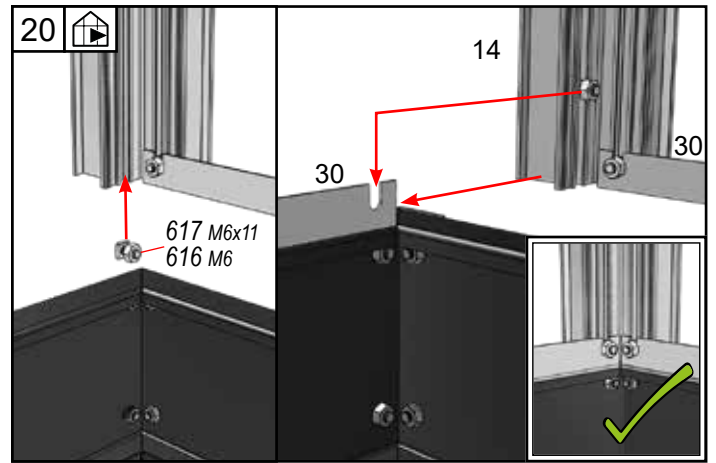
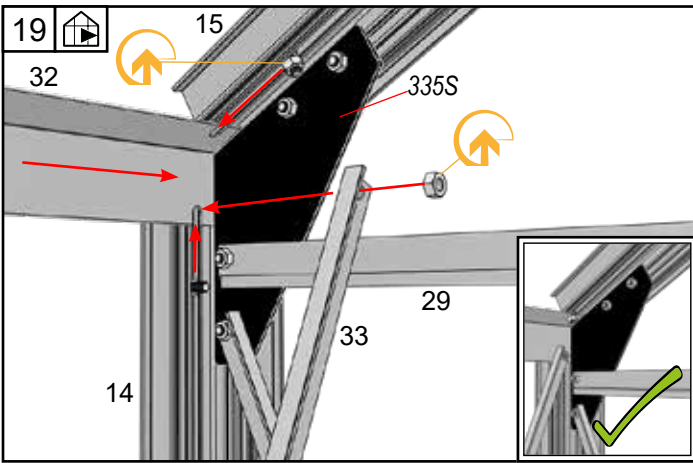
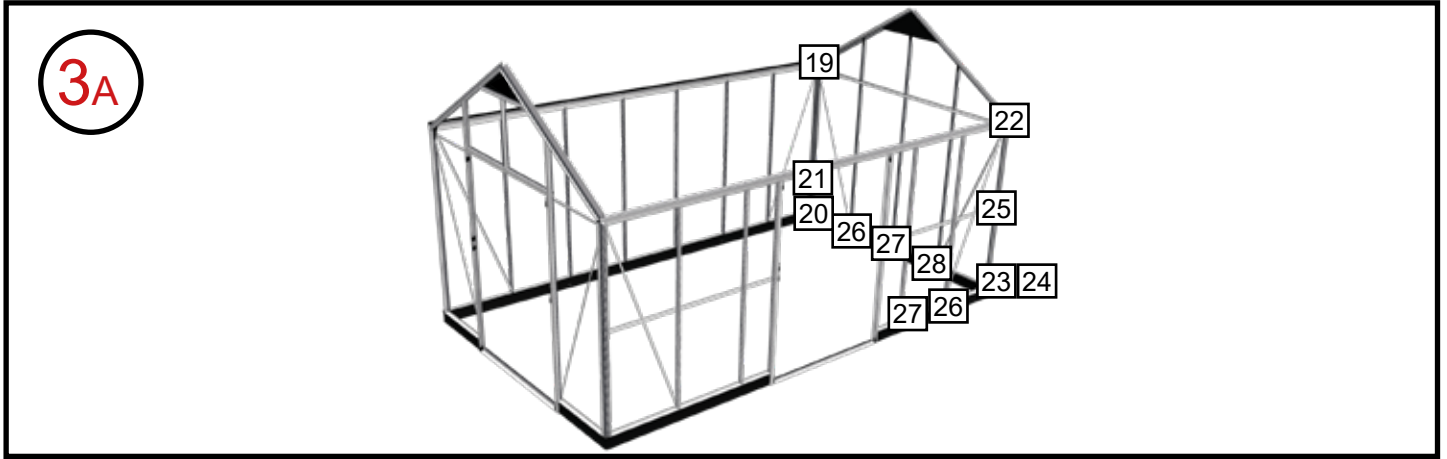

Samling - Assembly - Verbindung - Församling - Assemblage -  
Kokoaminen - Montaż stelaża

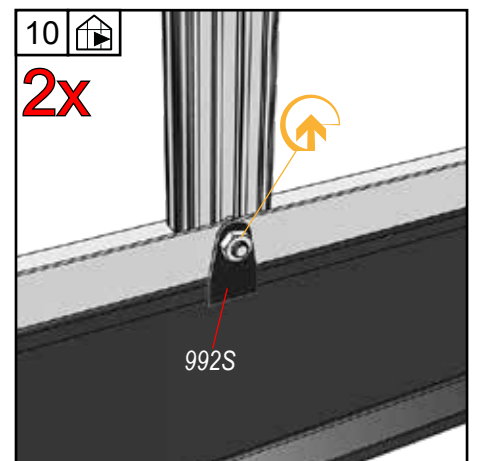
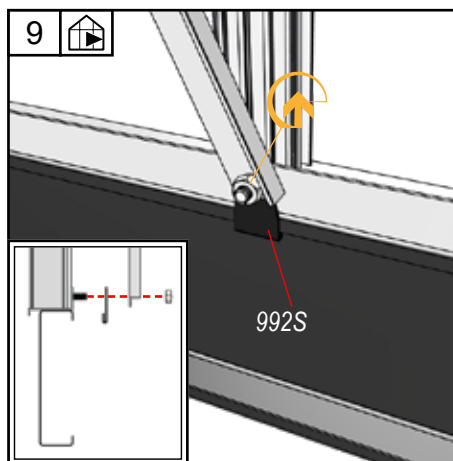
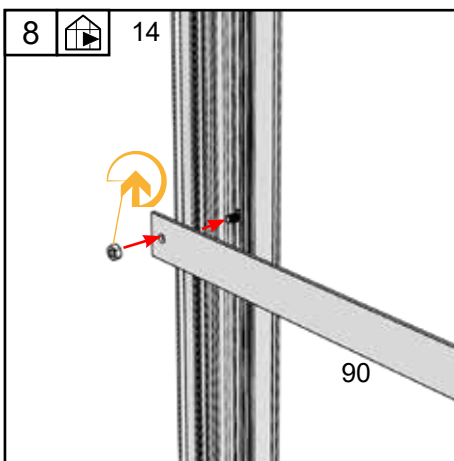
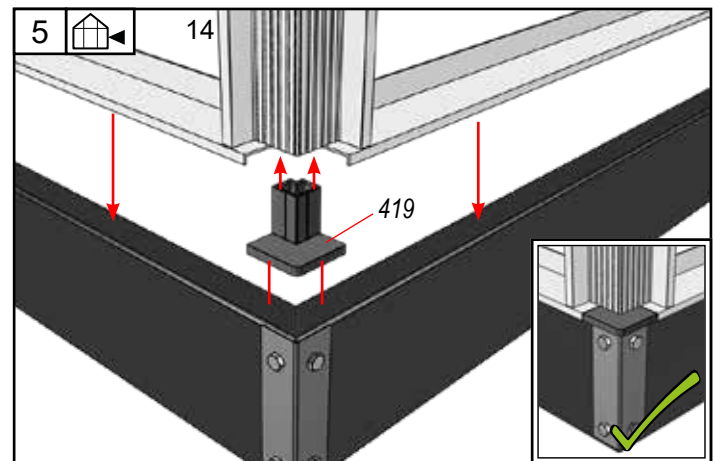
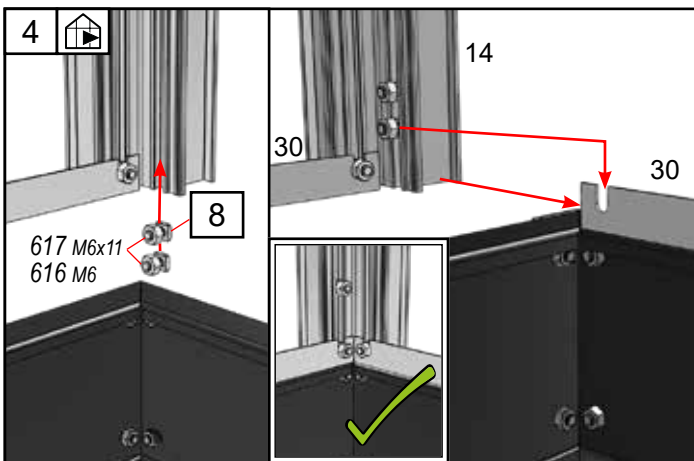
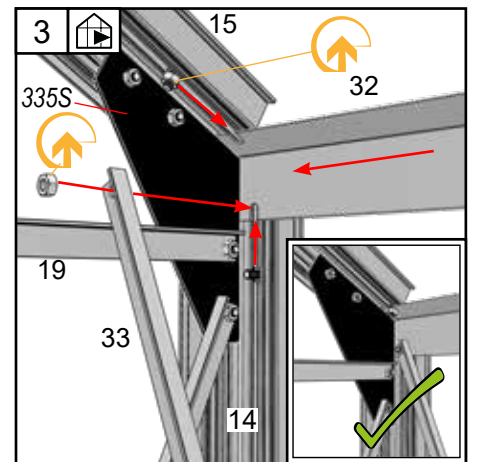
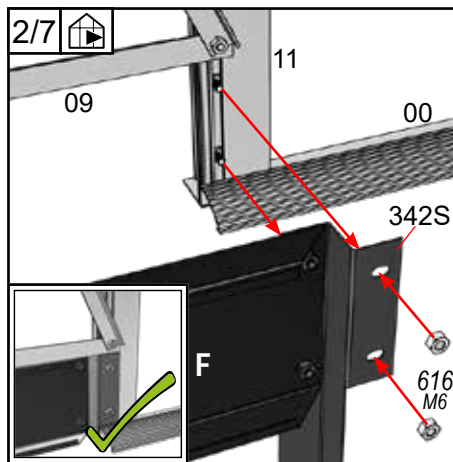
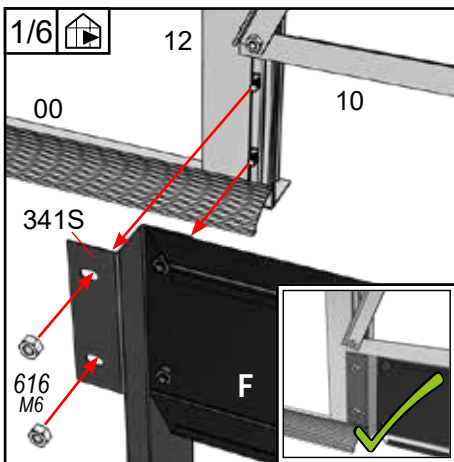
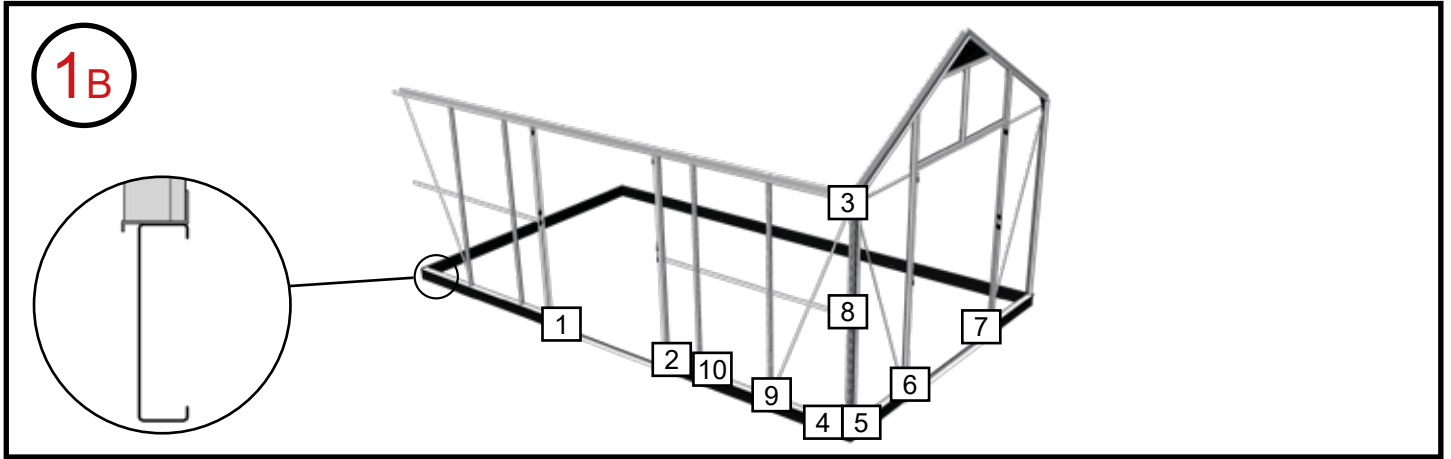

Samling - Assembly - Verbindung - Församling - Assemblage -  
Kokoaminen - Montaž stelaža

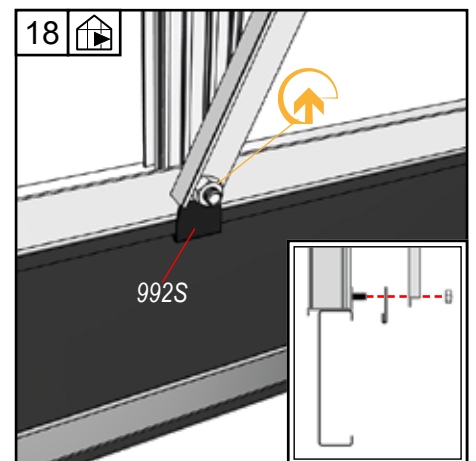
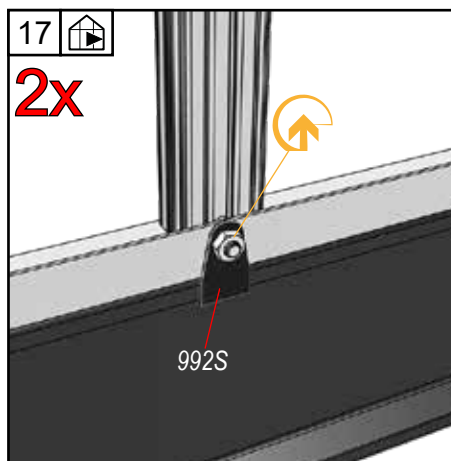
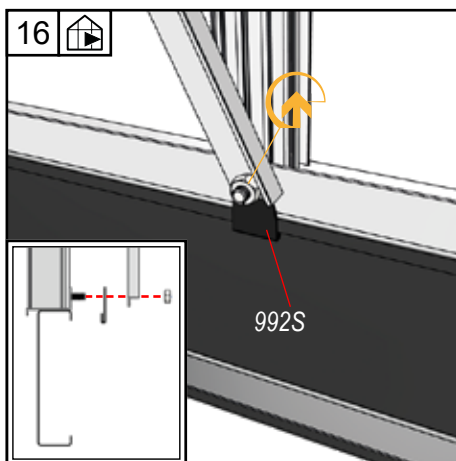
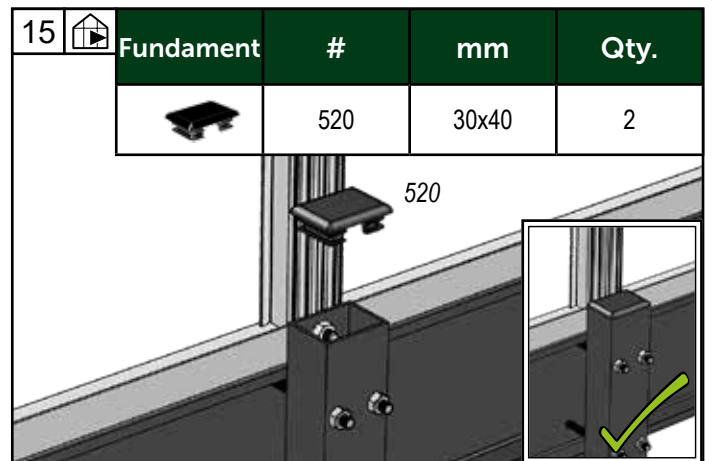
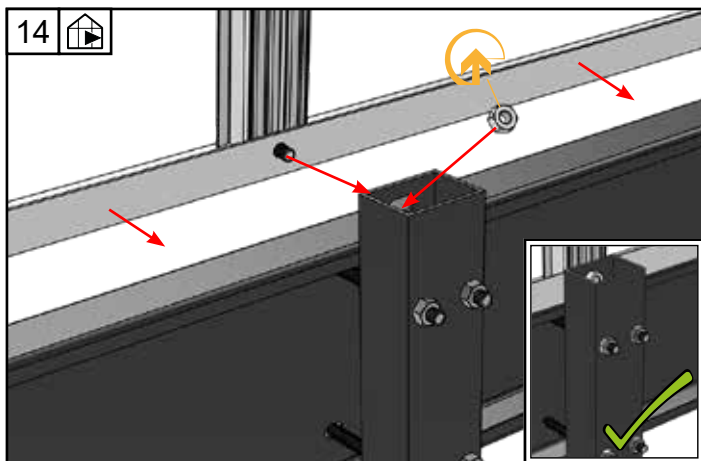
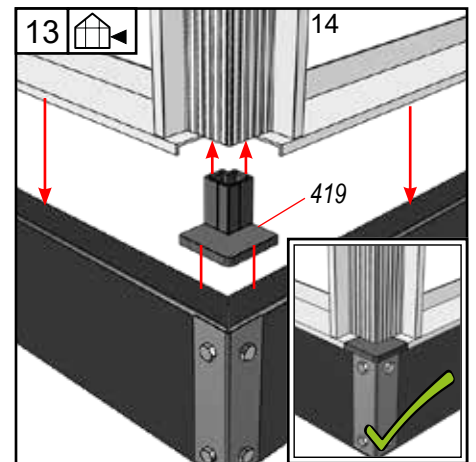
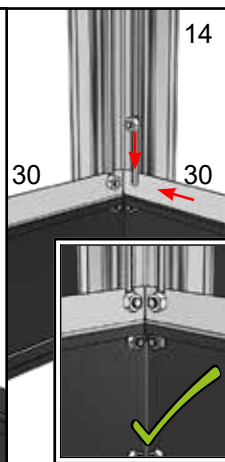
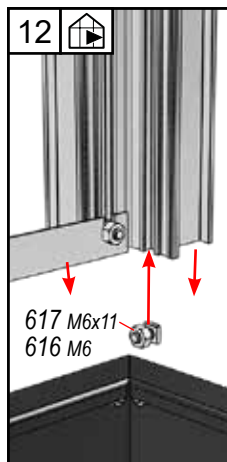
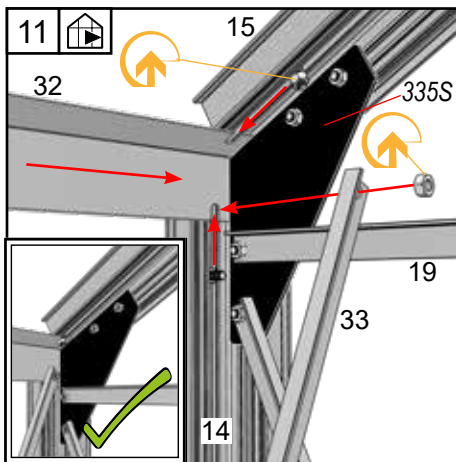
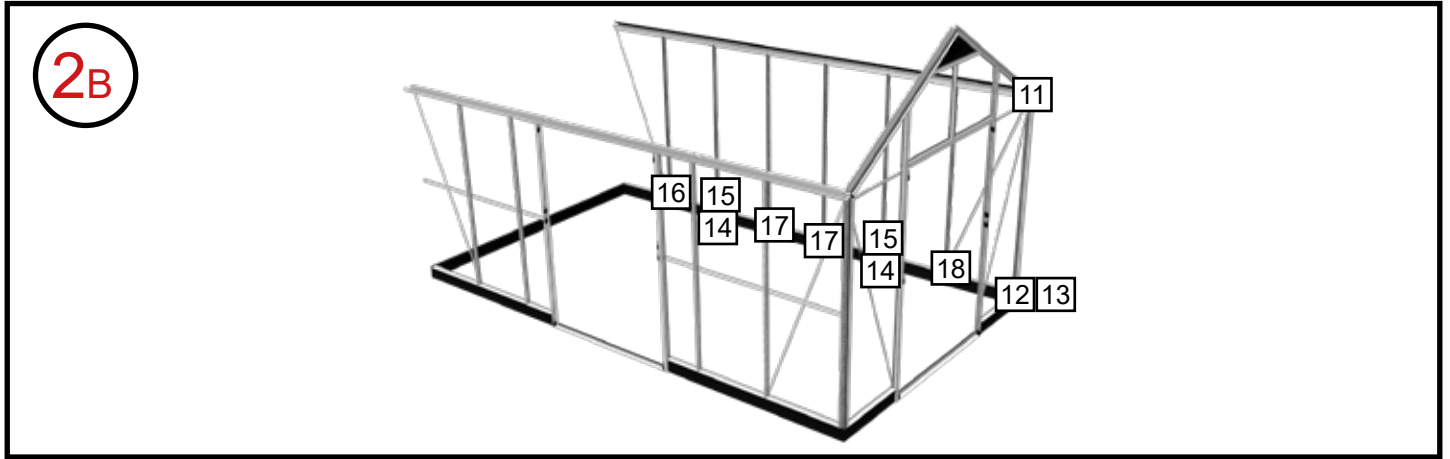

Samling - Assembly - Verbindung - Församling - Assemblage -  
Kokoaminen - Montaž stelaža

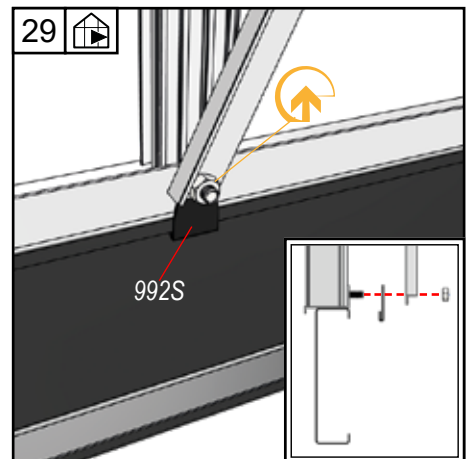
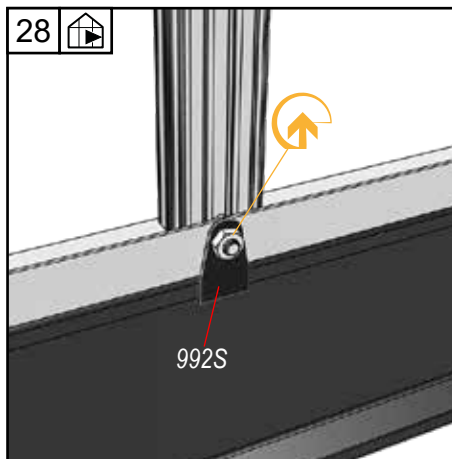
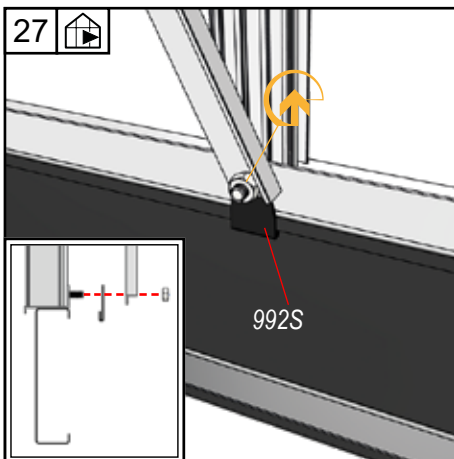
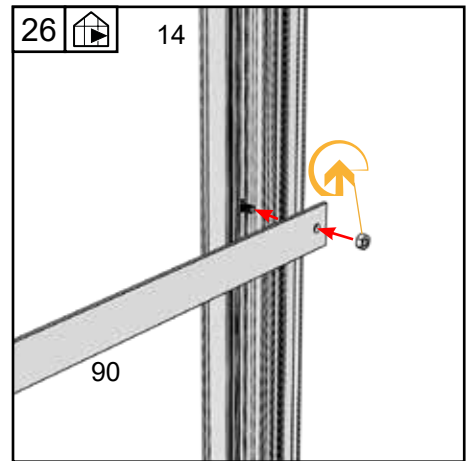
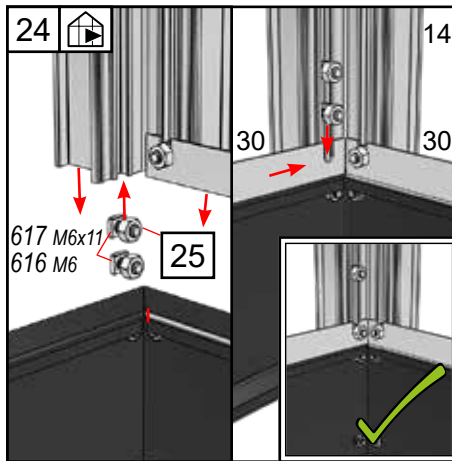
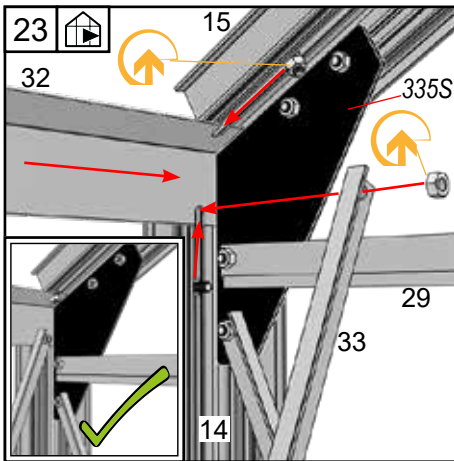
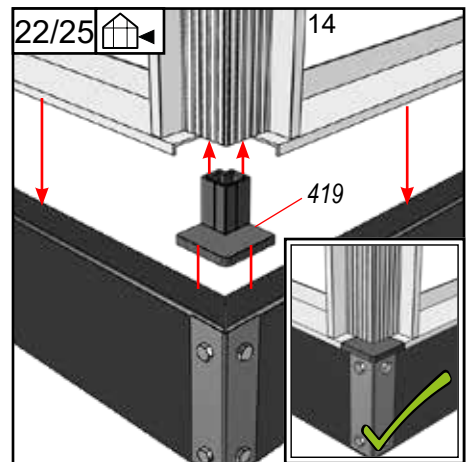
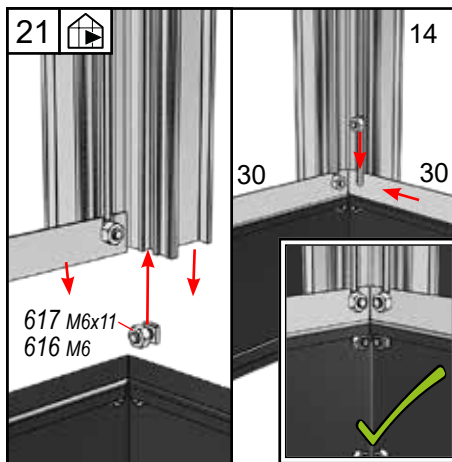
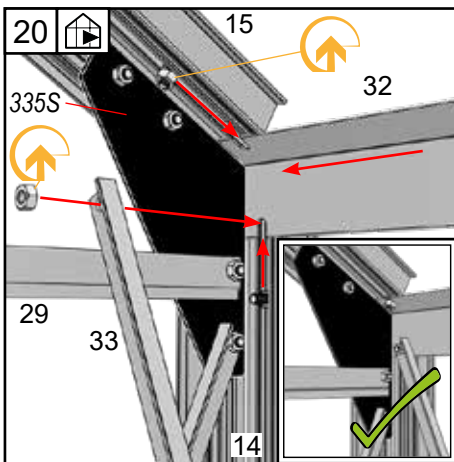
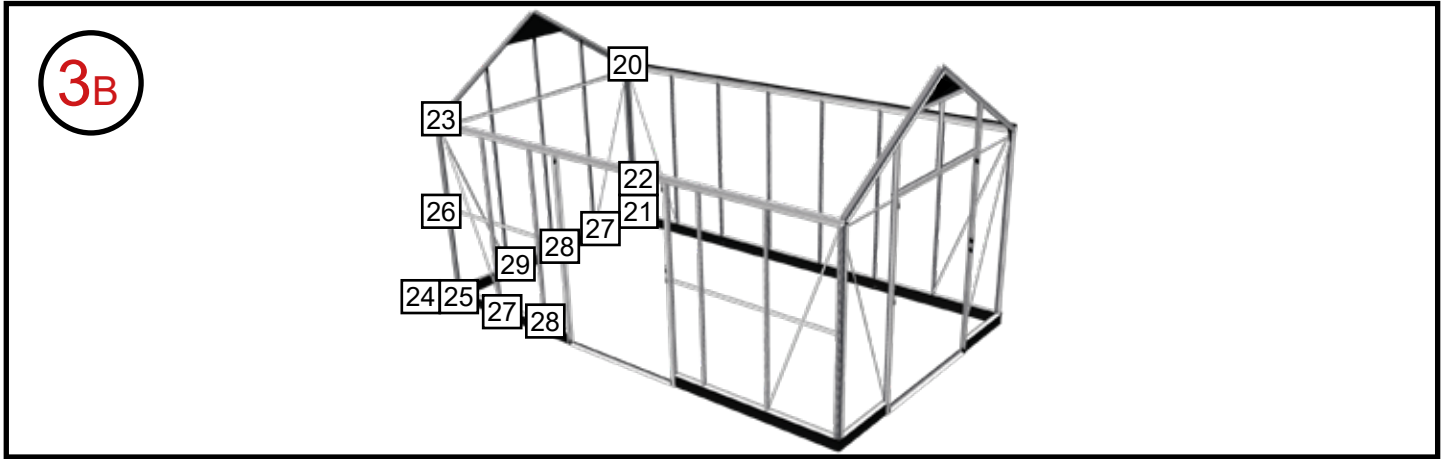

# Tag - Roof - Dach - Tak - Toit - Dak - Katto



3 mm - Hærdet glas - Toughened glass - Sicherheitsglas (ESG) - Säkerhetsglas - Verre Trempé - Gehard Glas - Karkaistu Turvalasi - Szkło Hartowane

BOX 11	#	mm	Qty		#	mm	Qty
	M2465	2465	6		G	517x700	2
					H	578x700	2
					I	691X574 (574/394/400)	2

Samling - Assembly - Verbindung - Församling - Assemblage -  
Kokoaminen - Montaž stelaža

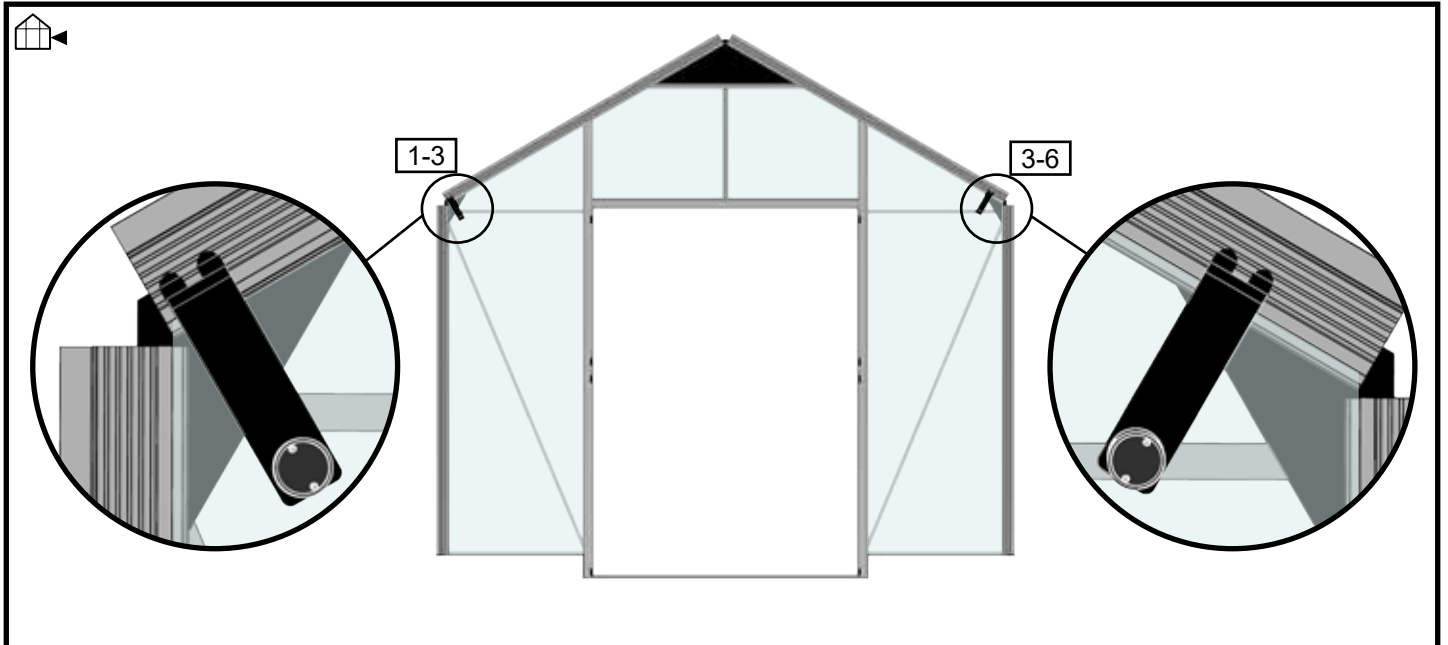

	#	mm	Qty.
	392S	-	2
	470	-	4
	668	M4 x 16	4
	669	M4	4

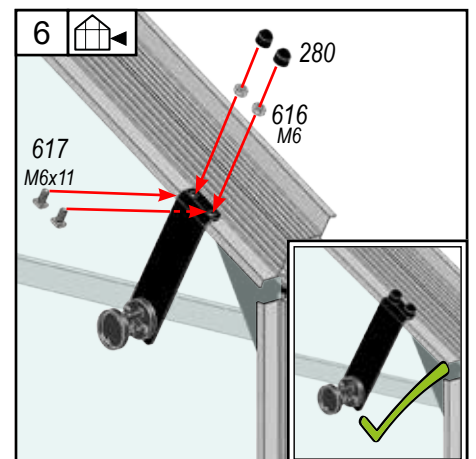
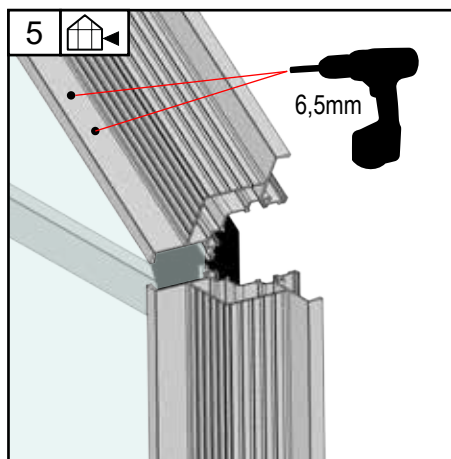
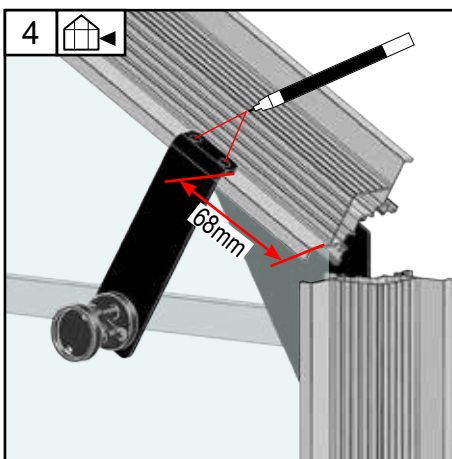
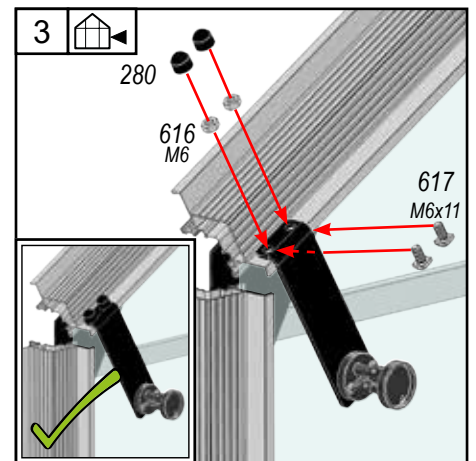
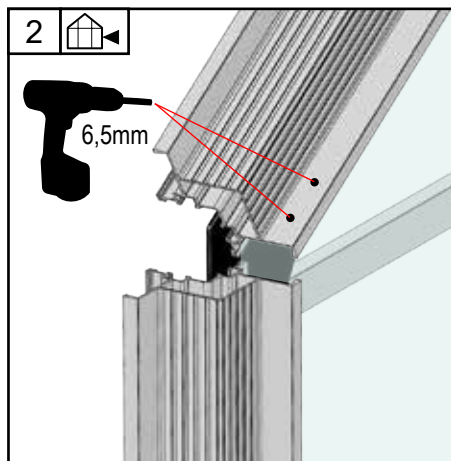
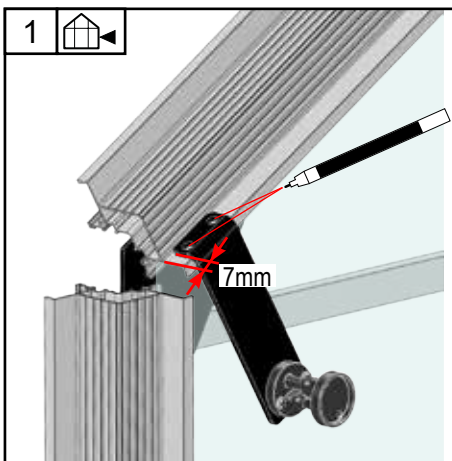
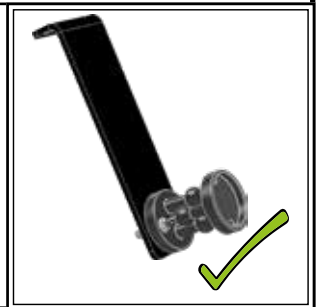
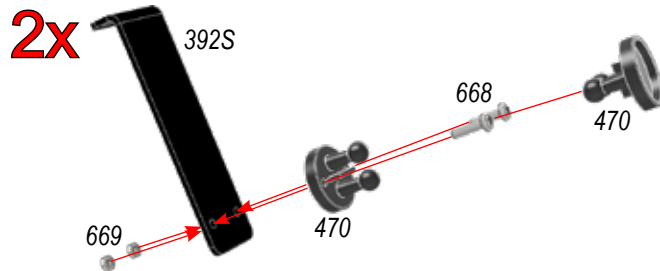



# Dør - Door - Tür - Dörr - Porte - Deur - Ovi - Drzwi

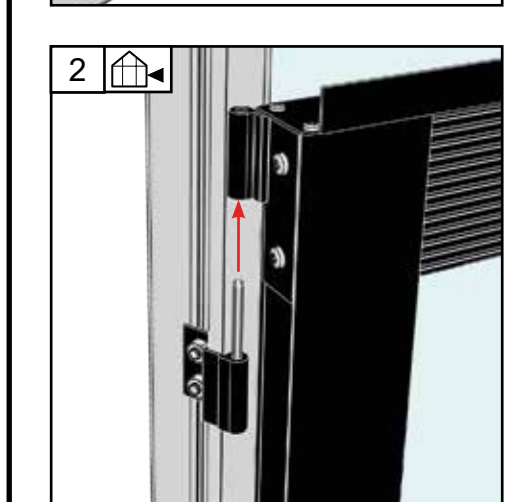
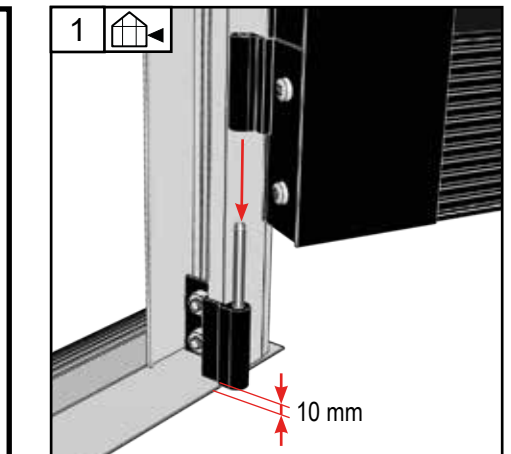
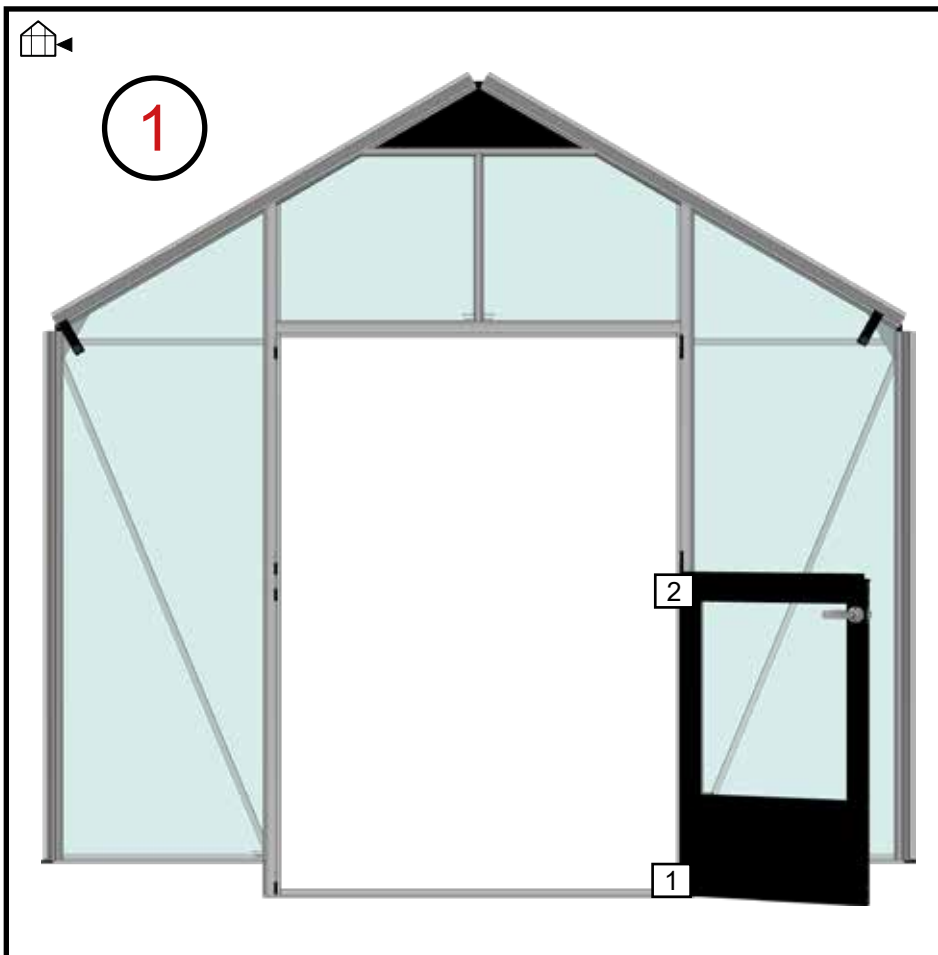
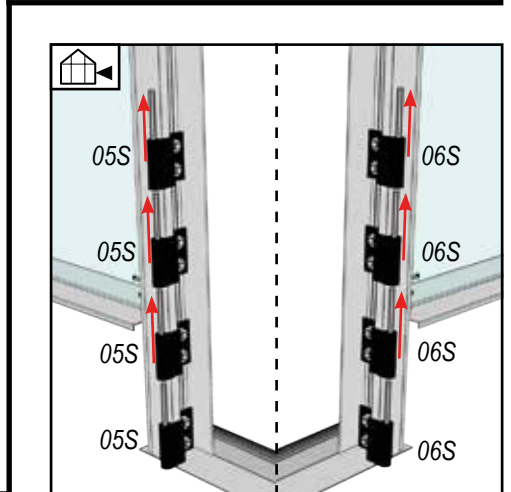
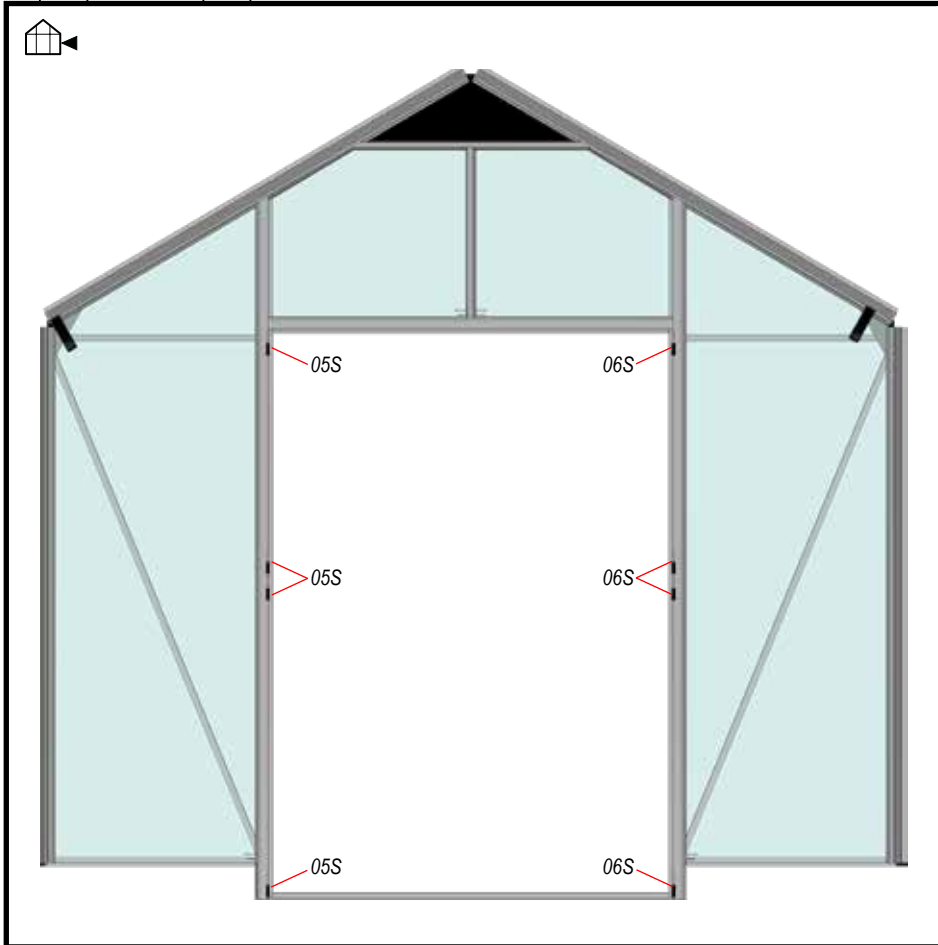

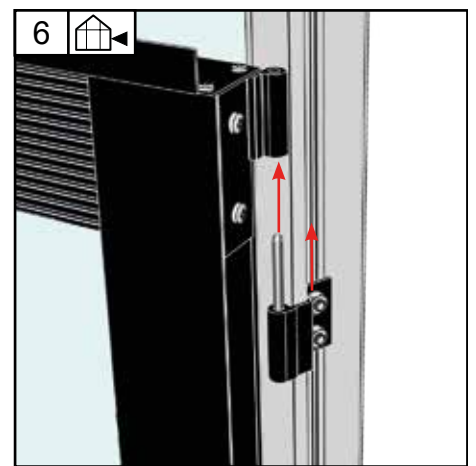
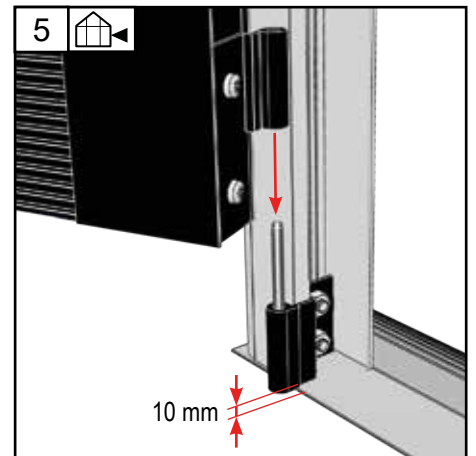
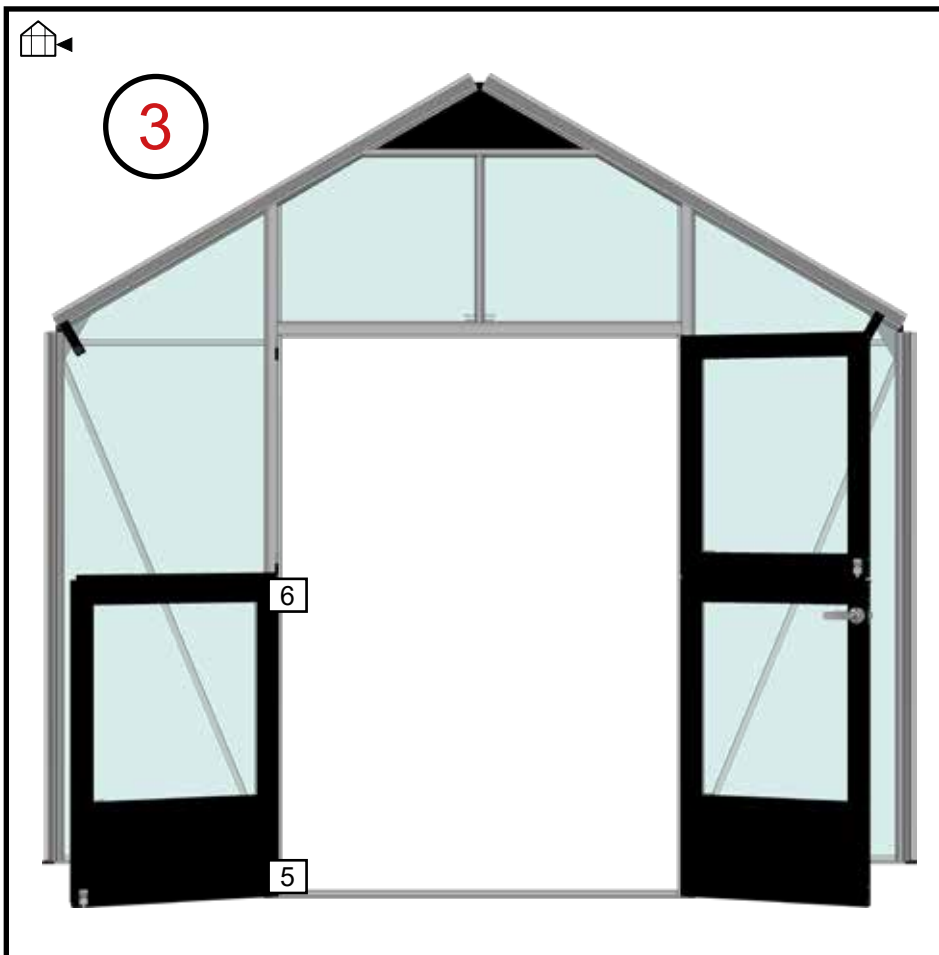
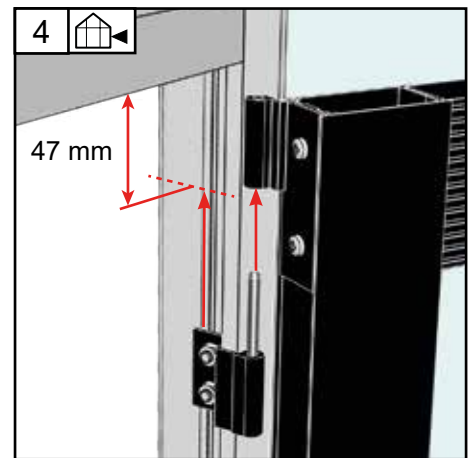
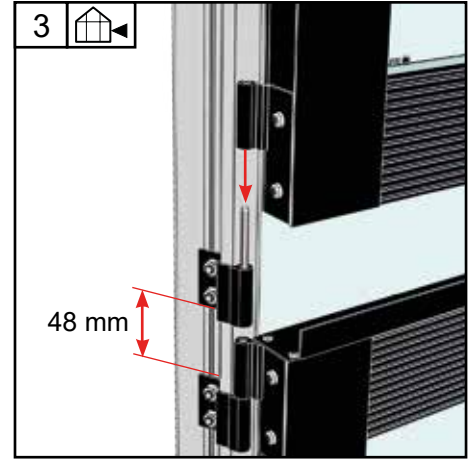
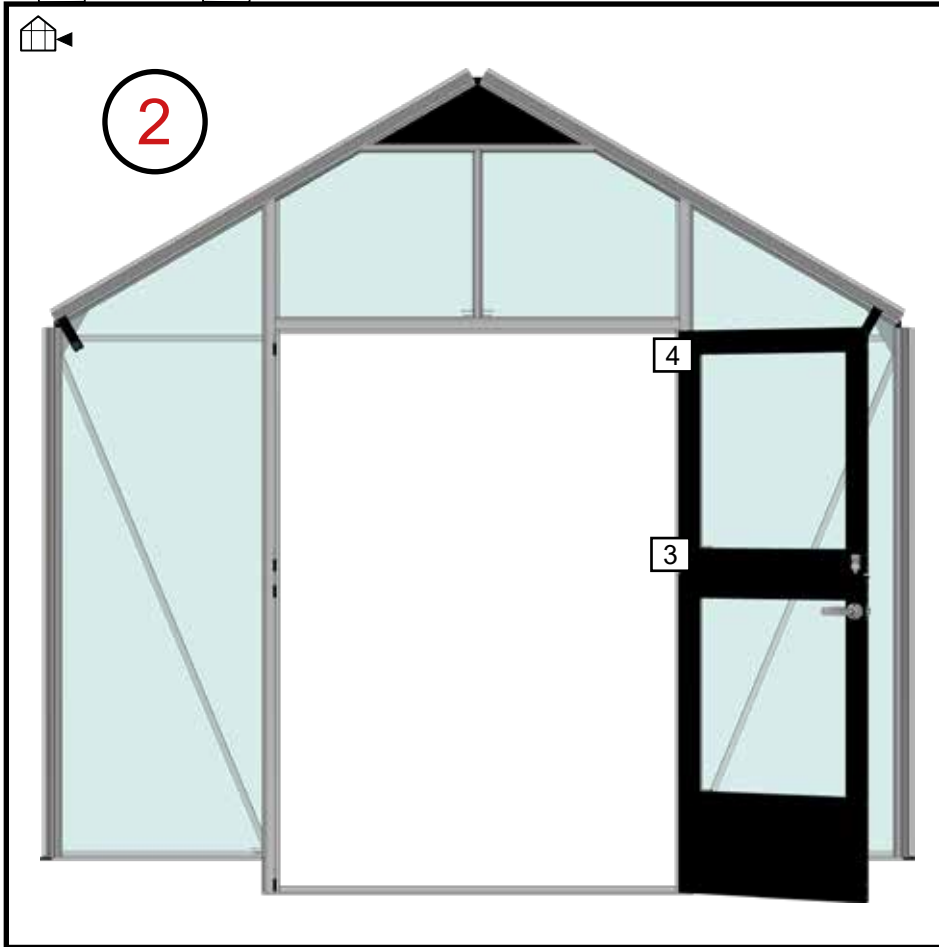
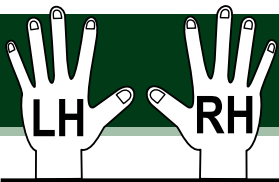

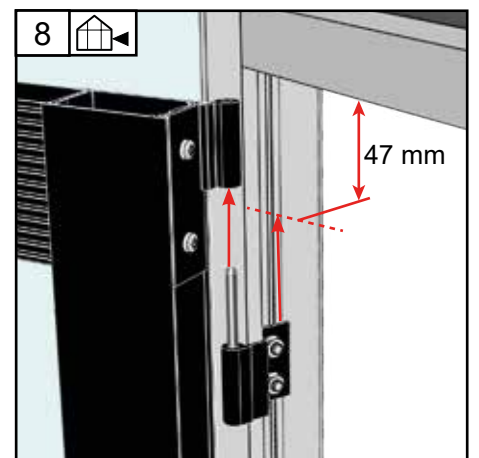
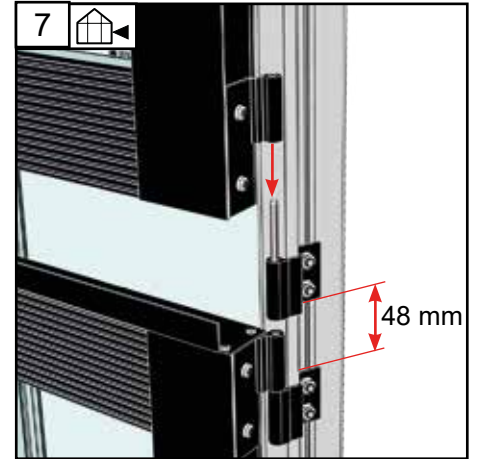
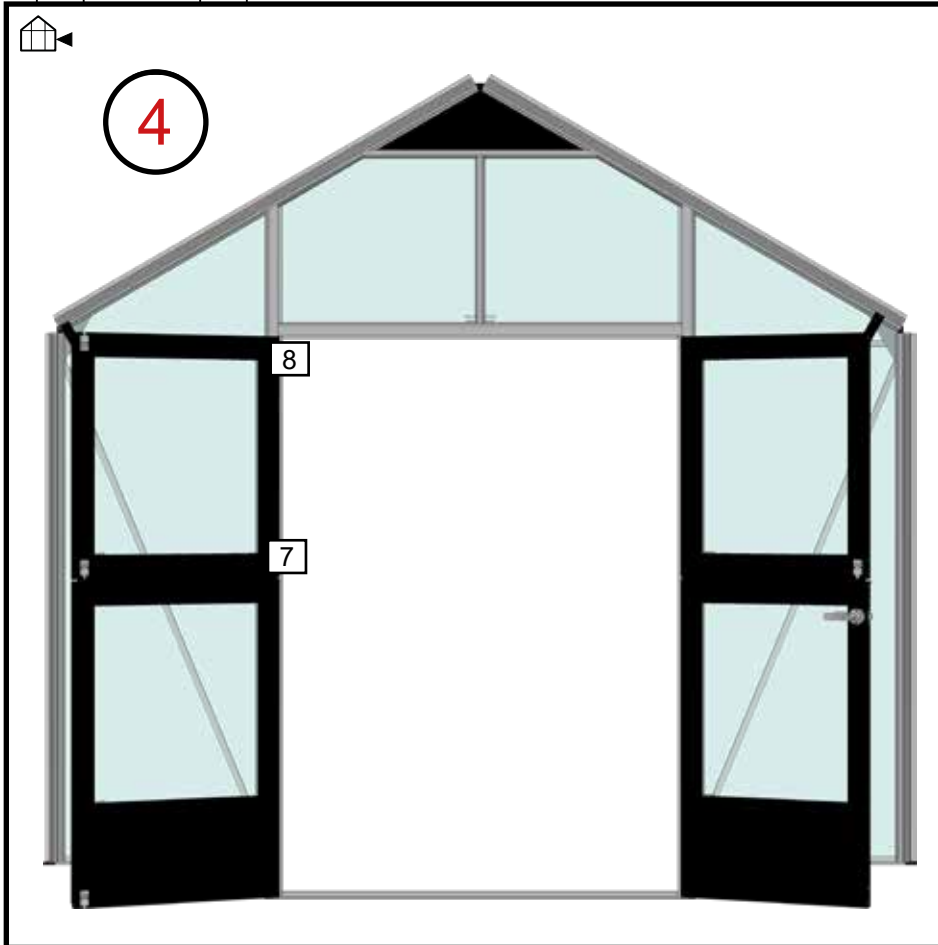

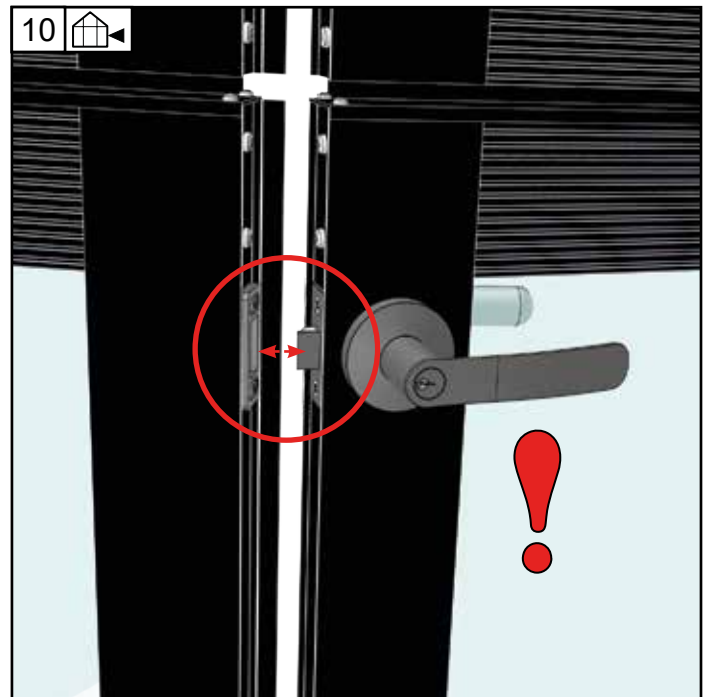
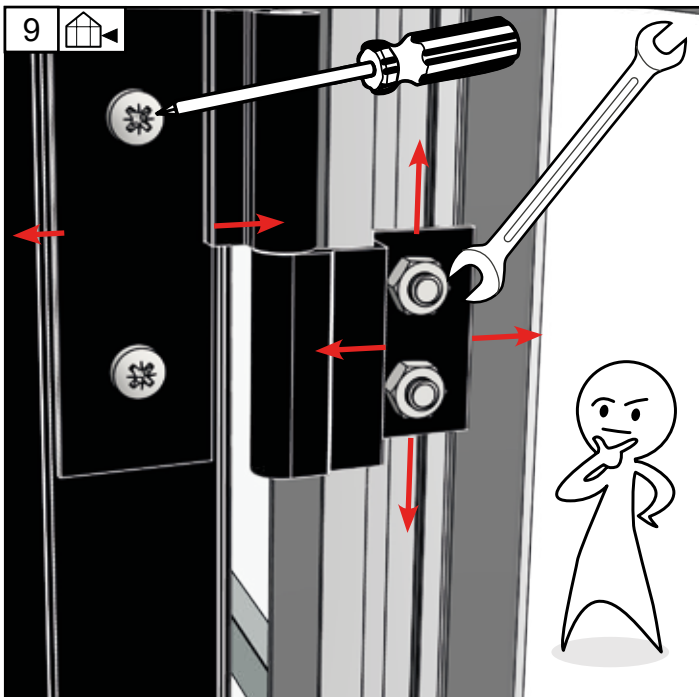
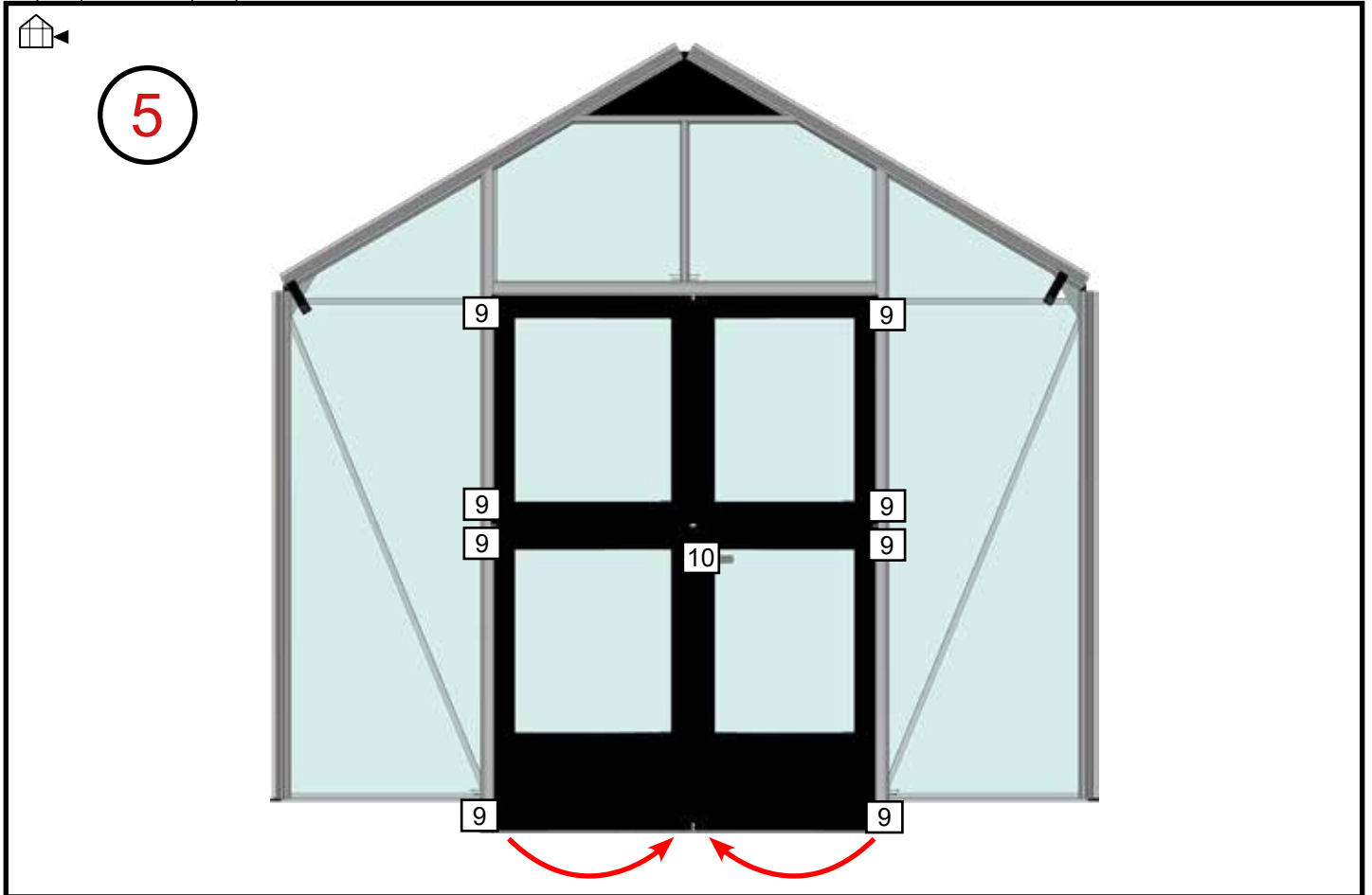

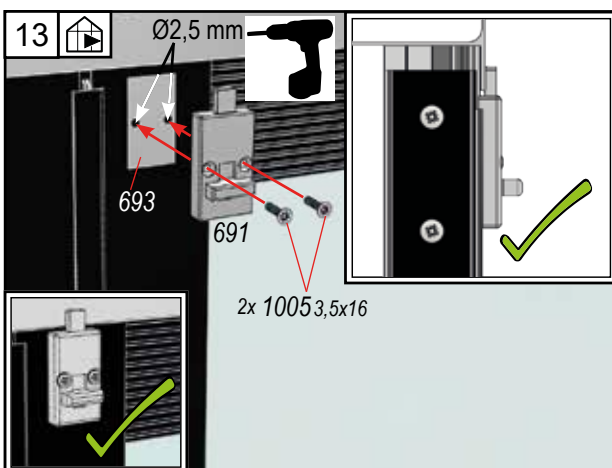
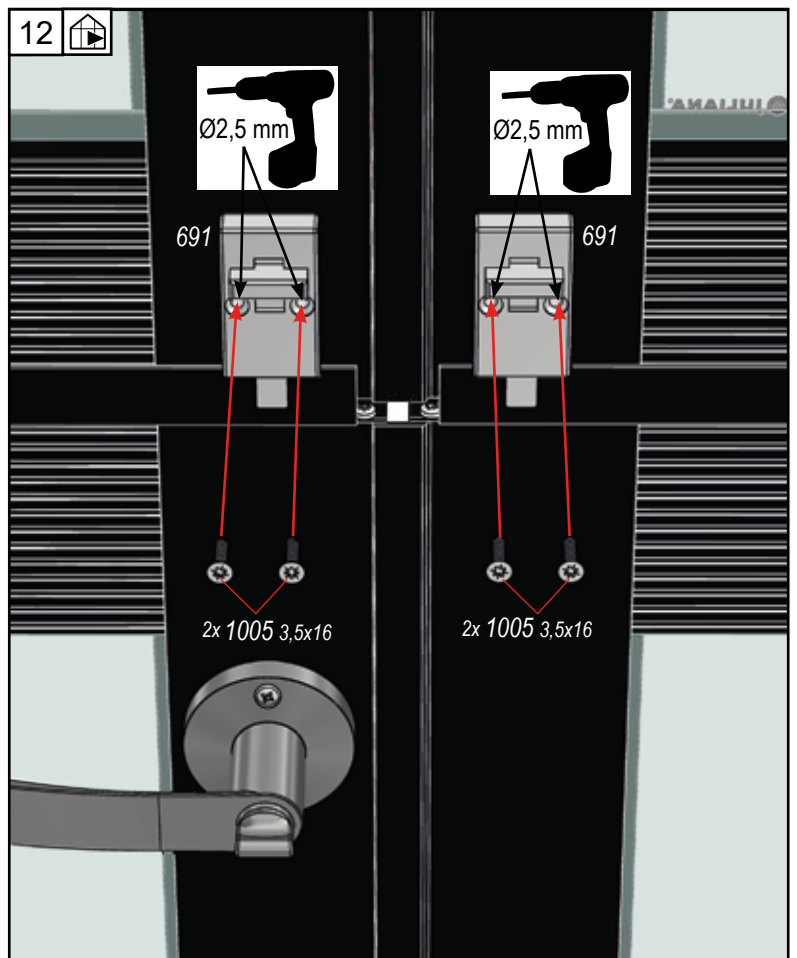
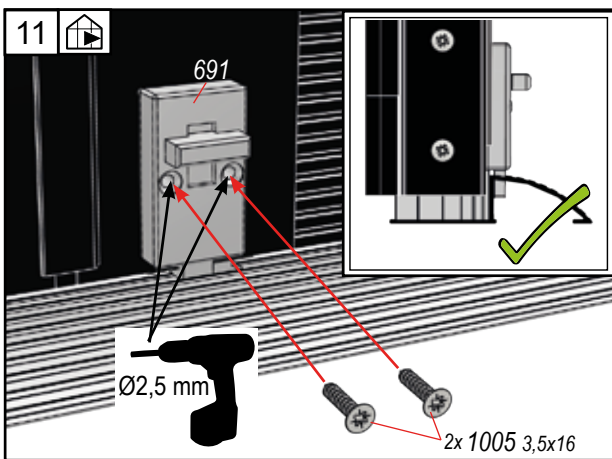
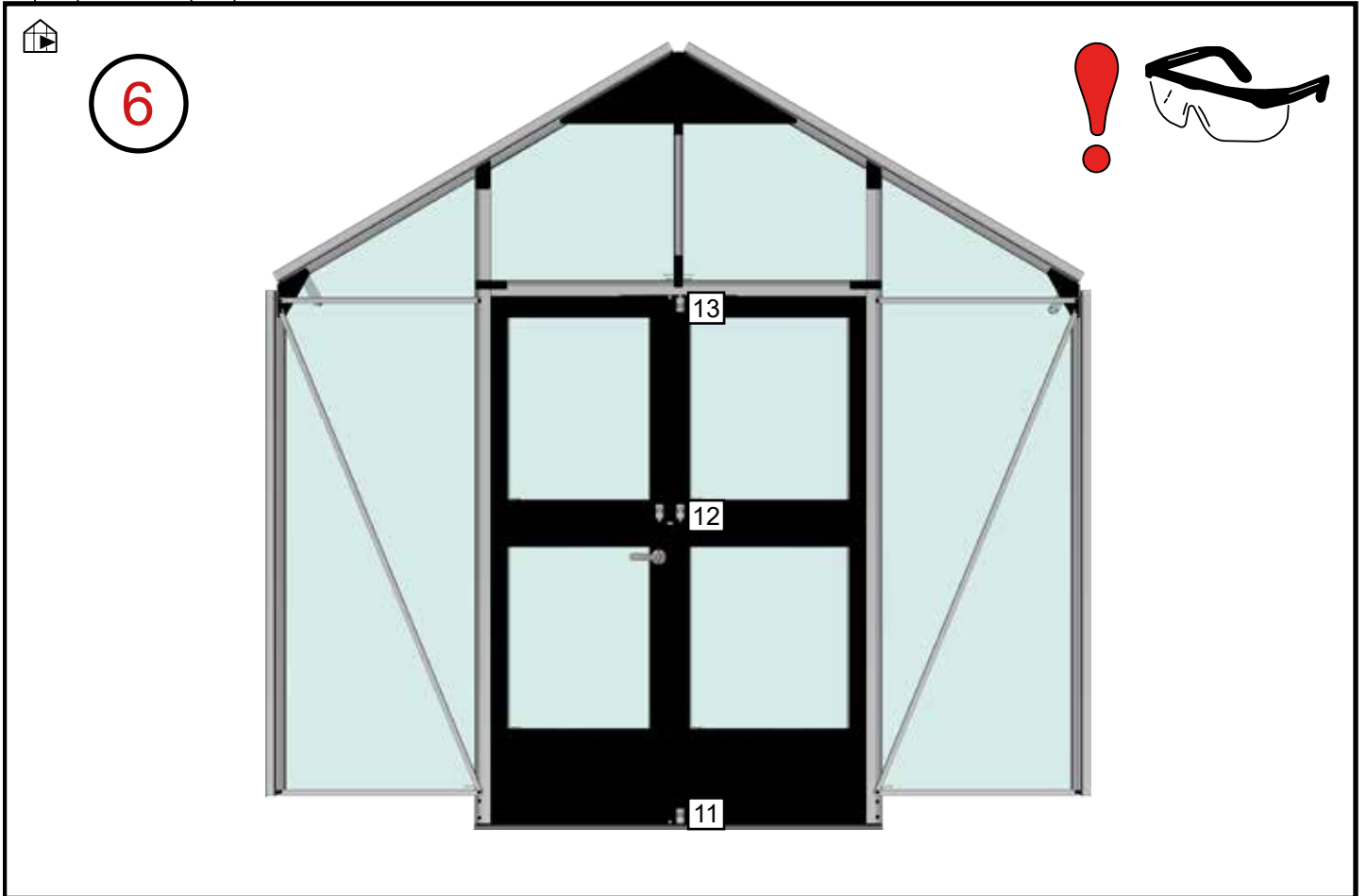
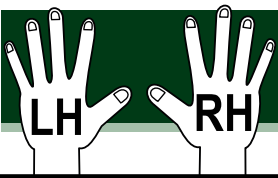

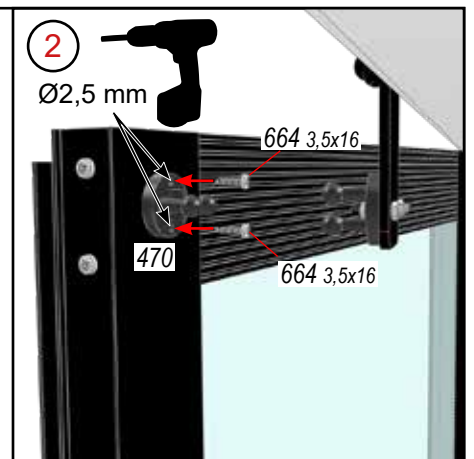
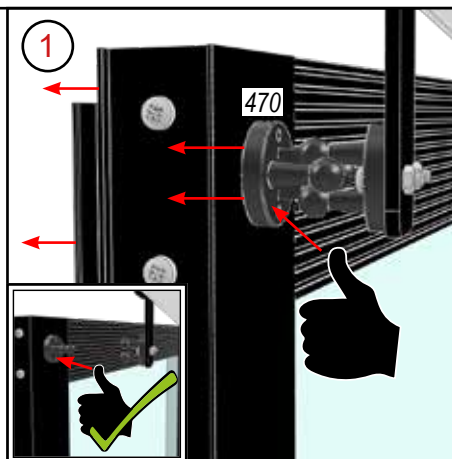
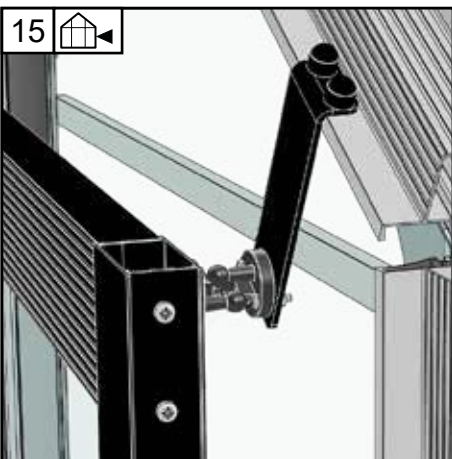
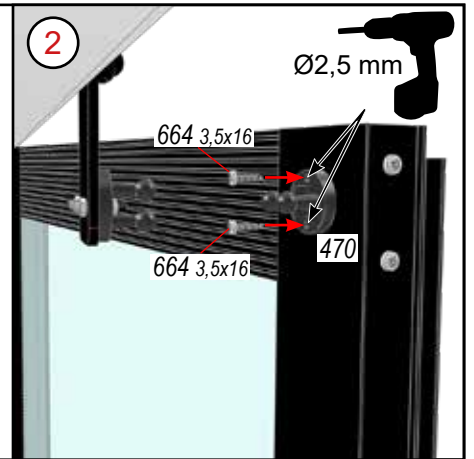
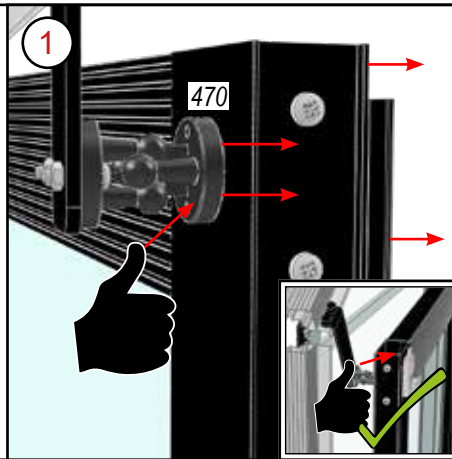
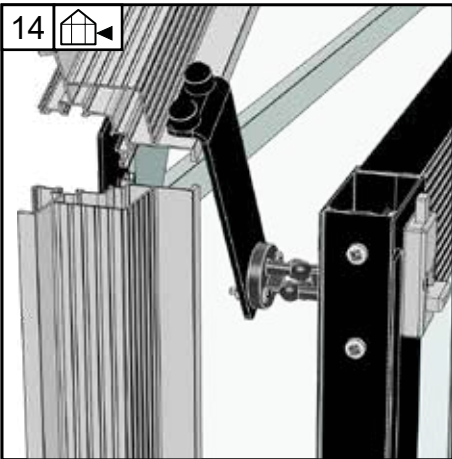
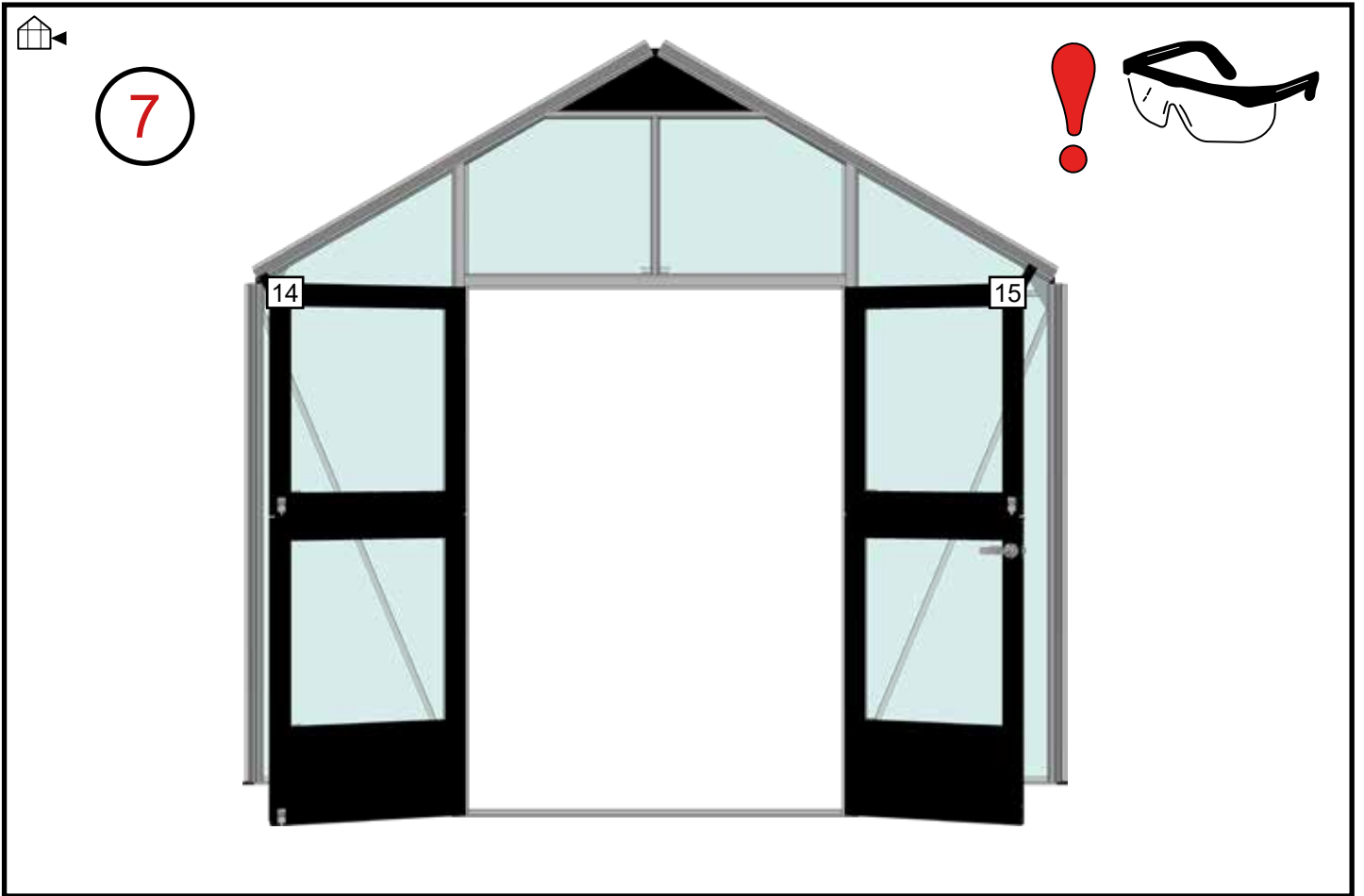
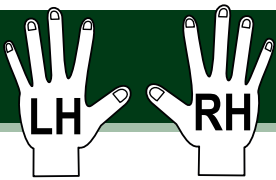

Vinduer - Windows - Fenster - Fönster - Fenêtres -  
Ramen - Ikkunoita - Okno



Afslutning - Finishing - Fertigstellung - Slutför - Aperçu -  
Afwerking - Viimeistely - Wykończenie

